



Abrams Municipal Airport  
Advisory Commission

**SPECIAL MEETING AGENDA**  
**WEDNESDAY, FEBRUARY 22, 2023 – 6:30 P.M.**  
**COUNCIL CHAMBERS, CITY HALL**  
**310 GREENWOOD ST., GRAND LEDGE MI 48837**

- I. ROLL CALL OF COMMISSION**
  
- II. PLEDGE OF ALLEGIANCE**
  
- III. AUDIENCE PARTICIPATION**
  
- IV. 4D0 AIRPORT LAYOUT PLAN UPDATE – Recommendation to City Council.**
  
- V. AUDIENCE PARTICIPATION**
  
- VI. COMMUNICATIONS FROM THE MEMBERS**
  
- VII. ADJOURNMENT**

Please click the link below to join the webinar:

<https://us02web.zoom.us/j/83926727901>

Or One tap mobile:

US: +13126266799,,83926727901# or +16468769923,,83926727901#

Or Telephone:

Dial (for higher quality, dial a number based on your current location):

US: +1 312 626 6799 or +1 646 876 9923 or +1 646 931 3860 or +1 301 715 8592 or +1 305 224 1968 or  
+1 309 205 3325 or +1 360 209 5623 or +1 386 347 5053 or +1 408 638 0968 or +1 507 473 4847 or +1  
564 217 2000 or +1 669 444 9171 or +1 669 900 6833 or +1 689 278 1000 or +1 719 359 4580 or +1 253  
205 0468 or +1 253 215 8782 or +1 346 248 7799

Webinar ID: 839 2672 7901

International numbers available: <https://us02web.zoom.us/j/83926727901>

February 28, 2023

Draft Document for City Council  
Meeting 2/27/2023

Ms. Jennifer Moore  
MDOT Office of Aeronautics  
2700 Port Lansing Road  
Lansing, MI 48906

Subject: Abrams Municipal Airport (4D0)  
Airport Layout Plan (ALP) Update  
Existing and Future Crosswind Runway 18/36 Removal

Dear Ms. Moore,

The City of Grand Ledge (City), owners of the Abrams Municipal Airport (4D0 or Airport), has been experiencing growth and further anticipated growth in their industrial park adjacent to 4D0, as well as anticipated growth north of the Airport. As such, the City elected to review the justification for the existing and future crosswind runways (Runway 18/36) to assess if there is a need to maintain them for existing or future needs of the flying public. The following presents the rationale used in making this determination and the associated changes that have been made to the ALP.

Since neither the existing or future Runway 18/36 is demonstrated to be necessary to maintain the utility of 4D0, the City has elected to remove them from the ALP and cease use of existing Runway 18/36. This will provide us with approximately 40 acres of airport owned property that can be used for other aeronautical purposes. Additionally, it will allow approximately 463 acres of public and privately-owned property to be removed from the encumbrances of the Airport Approach Plan (AAP), much of which is located within the City's industrial park to the south and the proposed Michigan Manufacturing Innovation Campus to the north, as shown in **Figure 1**. As such, the City has updated its Airport Layout Plan (ALP) for 4D0 to reflect these changes and the revisions to each sheet are noted below.

Existing Runway 18/36 is currently 2,559 feet long by 120 feet wide and is a grass runway that traverses through the approach to Runway 9. Due to limitations at both ends of the runway, each runway threshold is displaced, which limits the amount of runway available for landing aircraft. Runway 18 has 2,170 feet available for landing while Runway 36 has 2,173 feet. These displacements reduce the utility of the runway.

**Table 1** from the 2016 ALP Narrative Report illustrates that Runway 9/27 is classified with a B-II Runway Design Code while Runway 18/36 is an A-I (S) which means it is designed for small aircraft exclusively. The B-II classification of 4D0 is based upon an assessment completed in 2016 as part of the ALP update.

**Table 2** references the FAA Allowable Crosswind components by Runway Design Code. As shown, since Runway 9/27 is a B-II runway, the allowable crosswind component is 13 knots.

Federal Aviation Administration (FAA) airport design criteria suggests that an airport should have runways that align with local wind conditions at least 95 percent (95%) of the time. If this cannot be accomplished with the primary runway, then a crosswind runway is justified, based upon the critical aircraft.

**Table 1 – 2016 ALP Update Narrative Report Runway Design Information**

	Primary Runway 9/27			Runway 18/36		
	0-5 Years	6-10 Years	11-20 Years	0-5 Years	6-10 Years	11-20 Years
9. Runway Design Code (RDC)	Runway 9 B-II(S)-5000  Runway 27 B-II-VIS	Runway 9 B-II(S)-5000  Runway 27 B-II-VIS	Runway 9 B-II(S)-5000  Runway 27 B-II-VIS	A-I(S)-VIS	A-I(S)-VIS	A-I(S)-VIS
• Aircraft Approach Category (AAC)	B	B	B	A	A	B
• Airplane Design Group (ADG)	II	II	II	I	I	I
• Approach Visibility Minimums	Runway 9 1 SM  Runway 27 VISUAL	Runway 9 1 SM  Runway 27 VISUAL	Runway 9 1 SM  Runway 27 VISUAL	VISUAL	VISUAL	VISUAL
10. Runway Reference Code (RRC)**	**	**	**	**	**	**
• Runway – Taxiway Separation	240 feet	240 feet	240 feet	NA	NA	NA
• Departure Reference Code (DPRC)	B/II	B/II	B/II	NA	NA	NA
• Approach Reference Code (APRC)	Runway 9 B/II/5000  Runway 27 B/II/VIS	Runway 9 B/II/5000  Runway 27 B/II/VIS	Runway 9 B/II/5000  Runway 27 B/II/VIS	NA	NA	NA
• Approach Visibility Minimums	Runway 9 5000  Runway 27 VISUAL	Runway 9 5000  Runway 27 VISUAL	Runway 9 5000  Runway 27 VISUAL	VISUAL	VISUAL	VISUAL

Source: Mead & Hunt, Inc. (2016)

\*\*Change 1 to FAA Advisory Circular 150/5300-13a, *Airport Design*, introduced Approach and Departure Reference Codes to replace Runway Reference Code.

Source: 2016 Abrams Municipal Airport Layout Plan Narrative Report

**Table 2 – FAA Allowable Crosswind Components by Runway Design Code**

RDC	Allowable Crosswind Component
A-I and B-I *	10.5 knots
A-II and B-II	13 knots
A-III, B-III, C-I through D-III D-I through D-III	16 knots
A-IV and B-IV, C-IV through C-VI, D-IV through D-VI	20 knots
E-I through E-VI	20 knots

\* Includes A-I and B-I small aircraft.

Source: FAA Advisory Circular 150/5300-13B *Airport Design*

In reviewing **Table 3**, which is taken from the 2016 ALP Narrative Report, Runway 9/27 provides 95.88 percent (95.88%) wind coverage for 13 knot winds under all weather conditions, which is the appropriate coverage for a B-II designated runway. This meets the crosswind component for B-II aircraft, which is the current classification for the airport, as noted in **Table 1**. Thus, a crosswind runway is not justified to meet the FAA design standards. Since a crosswind runway is not justified, any improvement of the existing runway would not be eligible for federal funding. Additionally, any development of the future Runway 18/36, as shown in the 2016 ALP, would not be eligible for federal funding, and thus must be a locally funded project based upon this analysis.

**Table 3 – All Weather Wind Coverage**

All Weather Crosswind (in knots)	Percent Wind Coverage			
	Runway 9	Runway 27	Runway 18	Runway 36
10.5	55.39%	74.32%	67.40%	57.89%
	91.36%		87.24%	
	98.75%			
13	57.44%	77.62%	71.16%	60.99%
	95.88%		92.59%	
	99.76%			
16	59.21%	80.14%	74.64%	64.06%
	99.18%		97.33%	
	99.96%			
20	59.56%	80.72%	76.21%	65.17%
	99.88%		99.24%	
	100.00%			

*Note: Single runway end coverages calculated with a 3 knot tailwind  
 Source: National Climatic Data Center, FAA Standard Wind Analysis tool  
 Station: 725390 Capital City  
 Period of Record: 2005-2014 based on 128,433 observations*

Source: 2016 Abrams Municipal Airport Layout Plan Narrative Report

**ALP SHEET CHANGES**

The ALP revisions made to reflect the removal of both the existing Runway 18/36 and future Runway 18/36 were limited to the features affected by the scope of the project. The following is a list of the changes made to the ALP plan set.

TITLE SHEET

- Added revision date to Index Sheet List
- Updated “Last Revised” date
- Renumbered sheets due to removal of Future Runway 18/36 Approach plans

DATA SHEET

- Removed Existing & Future Runway 18/36 information from the Runway Data table

Ms. Jennifer Moore

February 28, 2023

Page 4

- Removed Existing & Future Runway 18/36 information from the Declared Distances Table
- Removed Future Runway 18/36 information from the Airport Data Table
- Updated Airport Diagram to remove the Existing and Future Runway 18/36 runways
- Updated Revisions section of the title block

#### EXISTING AIRPORT LAYOUT PLAN

- Removed Existing Runway 18/36 information from the Runway Dimensional Information, Runway Safety Areas, Runway Data, and Declared Distances tables
- Removed Existing Runway 18/36 geometry and safety areas from the plan view
- Removed Future Runway 18/36 information from the Airport Data Table
- Updated Revisions section of the title block

#### FUTURE AIRPORT LAYOUT PLAN

- Removed Existing & Future Runway 18/36 information from the Runway Dimensional Information, Runway Safety Areas, Runway Data, and Declared Distances tables
- Removed Existing Runway 18/36 geometry and safety areas from the plan view
- Removed Future Runway 18/36 information from the Airport Data Table
- Updated Revisions section of the title block

#### TERMINAL AREA PLAN

- Removed Existing & Future Runway 18/36 geometry and safety areas from the plan view
- Updated Revisions section of the title block

#### AIRPORT AIRSPACE PLAN

- Removed Future Runway 18/36 information from the Approach Surface Dimensions table
- Removed Existing Runway 18/36 geometry and safety areas from the plan view
- Revised FAR Part-77 surfaces to remove Future Runway 18/36
- Updated Revisions section of the title block

#### EXISTING RWY 9 INNER APPROACH SURFACE PLAN

- Removed Existing Runway 18/36 geometry and safety areas from the plan view
- Updated Revisions section of the title block

#### EXISTING RWY 27 INNER APPROACH SURFACE PLAN

- No changes

#### AERIAL PLAN

- Removed Existing Runway 18/36 geometry and safety areas from the plan view
- Updated Revisions section of the title block

Ms. Jennifer Moore  
February 28, 2023  
Page 5

#### PROPERTY PLAN

- Removed Existing & Future Runway 18/36 information from the Runway Data table
- Removed Existing & Future Runway 18/36 geometry and safety areas from the plan view
- Removed areas related to the Future Runway 18/36 from the Future Land Interests table
- Added Future Land Release on the north side of the airport
- Updated Revisions section of the title block

#### SHEETS THAT HAVE BEEN REMOVED:

- Existing RWY 18 Inner Approach Surface Plan
- Existing RWY 36 Inner Approach Surface Plan
- Future RWY 18 Inner Approach Surface Plan
- Future RWY 36 Inner Approach Surface Plan

This set of drawings is for MDOT records and expected to replace the current ALP plan set on file. We will also use this set of plans for any future planning or engineering project. We additionally request that MDOT update the AAP to reflect these changes so the AAP can be filed with the appropriate municipal entities to maintain compliance with the Zoning Enabling Act.

Should you have any questions, please contact me at (517) 622-7924. CAD files of the ALP plan set will be transmitted directly to you from our consultant.

Sincerely,  
City of Grand Ledge

Adam Smith  
City Manager

Attachment/Enclosure: ALP PDF (attached to this letter) and CAD Files (to be sent under separate cover)

Cc: Stephanie Ward, Mead & Hunt

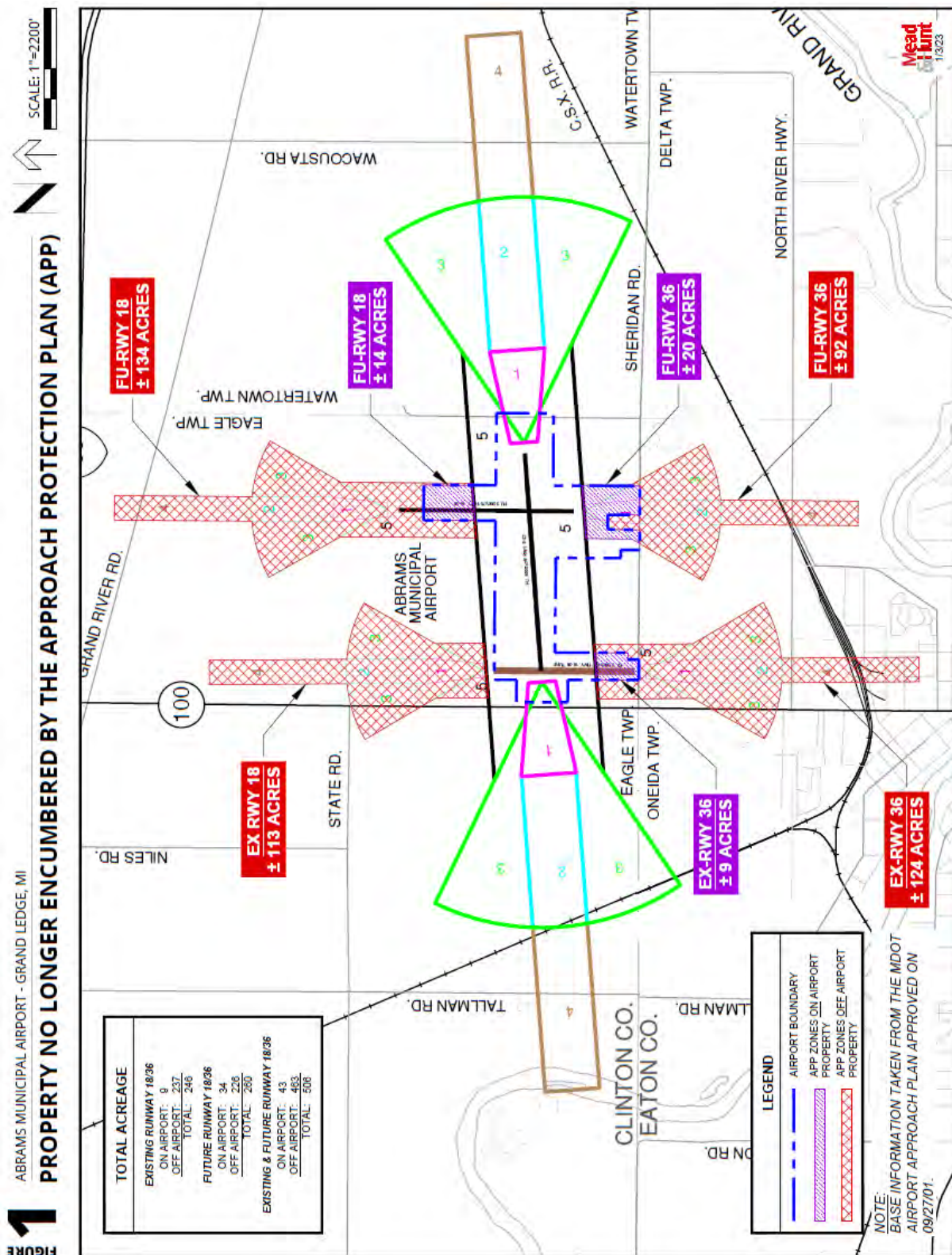

Ms. Jennifer Moore  
February 28, 2023  
Page 7

**Updated Airport Layout Plan Set**

RICK SNYDER  
GOVERNOR

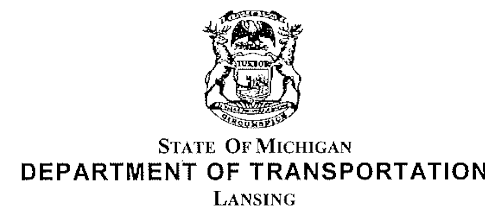

November 19, 2018

Mr. Adam Smith, Airport Manager  
Abrams Municipal Airport  
310 Greenwood Street  
Grand Ledge, Michigan 48837

Dear Mr. Smith:

Subject: Abrams Municipal Airport (4D0); Grand Ledge, Michigan  
Airport Layout Plan (ALP) Airspace Approval  
Airspace Case No. 2018-AGL-7029-NRA

Under the Federal Aviation Administration (FAA) State Block Grant program, the Michigan Department of Transportation's Office of Aeronautics (AERO) has been assigned the responsibility of coordinating FAA airspace studies for on-airport development occurring at all Michigan airports which are not classified as primary airports. Enclosed is a conditionally approved copy of the Abrams Municipal Airport, Airport Layout Plan (ALP), dated June 2018. This letter cancels or supersedes all prior ALP approvals. The ALP approval is based on recognition of and adherence to the following:

1. The approval is not to be considered a commitment of Federal funding for the proposed development. The FAA has concurred with the proposed development for planning purposes only based on current safety, utility, and efficiency standards. Actual development should comply with approved standards applicable at the time of construction. The airport will need to provide the FAA justification of need before seeking FAA financial participation in the following projects:

- Easements – approach end Runway 27 (to address tree obstructions)
- Future crosswind Runway 18/36 (replace turf and pave)
- Future hangar development
- Installation of Automated Weather Observing System (AWOS)
- Acquisition of through-the-fence properties

The airport sponsor shall agree to keep an accurate ALP updated at all times that is based on the most current design critical aircraft category. The sponsor, by approving this ALP, agrees to closely monitor aircraft usage, specifically for a change in critical aircraft.

2. Our approval does not infer or imply that the land in the airport vicinity is considered compatible with airport operations. Federal requirements stipulate:
- All development programs should be reasonably consistent with the plans of local and state planning agencies for the development in the airport vicinity.
  - That fair consideration has been given to the interest of communities in or near the airport.
  - That development programs provide for the protection and enhancement of the environment.

Aeronautics Building – 2700 Port Lansing Road, Lansing, Michigan 48906  
www.michigan.gov (517) 335-9283

LH-LAN-0 (01/11)

Adam Smith  
November 19, 2018  
Page 2 of 3

3. The FAA offers no objections to the proposed ultimate airspace utilization as depicted on the ALP based on considerations of safe and efficient use of airspace. The ALP has the status of "Plan on File" for the purpose of 14 CFR 77, Obstruction Evaluations, and 14 CFR 152, Airport Aid Program. A review of the airside landing area development was conducted according to the following 14 CFR's: -77, -152, and -157, Notice of Construction, Alteration, Activation, and Deactivation of Airports (reference Aeronautical Study Number 2018-AGL-7029-NRA). It should be noted that FAA cannot prevent erection of any structure near an airport. Airport environs can only be protected through state and local zoning ordinances, building regulations, and like requirements.

4. All development depicted on this ALP must comply with the National Environmental Policy Act (NEPA) of 1969. FAA environmental approval is required for all airport development actions depicted on this ALP. This would apply to development projects, even if there were no FAA funding involved in the project. Additional requirements concerning FAA NEPA approval can be found in FAA Order 5050.4B, "National Environmental Policy Act (NEPA) Implementing Instruction for Airport Actions."

5. To avoid conflicts with future development, we recommend you utilize the ALP when preparing leases. We further recommend you provide copies of this ALP and an updated Airport Approach Plan to the local zoning agencies and encourage them to adopt compatible land use criteria in and around the airport and to comply with MCL 125.3203 (Michigan Zoning Enabling Act, Act 110 of 2006). Please contact the Michigan Department of Transportation's Office of Aeronautics to request an updated Michigan Aeronautics Commission approved Airport Approach Plan. Copies should also be distributed to the Fixed Base Operators (FBO's) and airport users.

6. The Airport and Airway Improvement Act (49 USC 47107 (a) (16) (D)) requires the sponsor to eliminate any adverse effects on Federal facilities, or bear all costs to relocate those facilities, that are a result of an airport change. However, if AIP eligible construction/development items adversely affect FAA facilities, the cost of relocating the facilities may be eligible under AIP. If the proposed development requires any displaced or relocated FAA facility, the construction will have to be coordinated with the FAA in order to establish reimbursable funding for the engineering and relocation.

7. This approval does not include a detailed evaluation of actual construction. Prior to constructing any development on the airport, notice (FAA Form 7460-1) consistent with 14 CFR 77 must be filed with this office. This approval does not include approval for temporary construction equipment which may be used during actual construction, e.g., cranes, equipment staging areas, site access routes, etc. A separate Construction Safety/Planning Plan for any project should be reviewed by the FAA no less than 60 days prior to beginning any project. The airport must take all measures necessary during construction to ensure there are no runway incursions.

8. If development is planned with or without Aviation Trust Fund investments that will change the status or geometrics of runways, taxiways, aprons, or other operating airport surfaces, notice (FAA Form 7490-1) must be filed with this office consistent with 14 CFR 157. The airport should work with the State of Michigan to update the Airport Master Record, FAA Form 5010-1, to reflect new runway data and updated runway changes.

Adam Smith  
November 19, 2018  
Page 3 of 3

9. Any development that requires relocation or installation of FAA facilities will require a signed and executed reimbursable agreement with the FAA. After the FAA concurs with any proposed development and the environmental review is complete, the sponsor will need to request a reimbursable agreement from the FAA. A preliminary agreement between the FAA and the airport sponsor should be executed upon receipt of airport's letter so that the FAA can begin providing engineering services. FAA will then develop the final reimbursable agreement. On average, 18 months are required from the time the preliminary agreement is signed to the time the final reimbursable agreement is signed.

10. The FAA Flight Procedures Office (FPO) must be notified at least 5 days prior to any temporary displacement and/or relocation of the thresholds. The latitude/longitude and elevation of the displaced/new threshold locations, as well as any new Touch Down Zone elevation information, must be provided. The notification time is necessary for issuance of Notices to Airmen (NOTAMS). The airport manager is responsible for issuing all required local NOTAMS.

11. Any planned runway developments will require new FAA flight procedures. If the FAA concurs with these developments, there will need to be close coordination with different FAA offices. Development on new approaches will not begin until environmental approvals have been given and the sponsor requests the FAA FPO to initiate design of new approaches. Publication of revised Instrument Approach Procedures (IAP's) could take from 18 months to two years, after runway data is submitted. Review of this ALP does not constitute an automatic request for amended procedures.

We trust this letter provides a clear explanation of the conditions and terms of our approval. This approval letter also serves as acknowledgment of the understanding and acceptance of the review comments from the ALP review that were summarized in a letter dated July 31, 2018. If you desire further clarification, please contact Jennifer Forbes of our office at telephone number (517) 335-8153.

Sincerely,

*Mark W. Noel*

Mark W. Noel, P.E., Manager  
Planning and Development Section  
Office of Aeronautics

cc: AJW-327E  
AJW-C15A  
ASW/AIR-322  
DET-ADO  
FAA SMO  
S. Ward - M&H

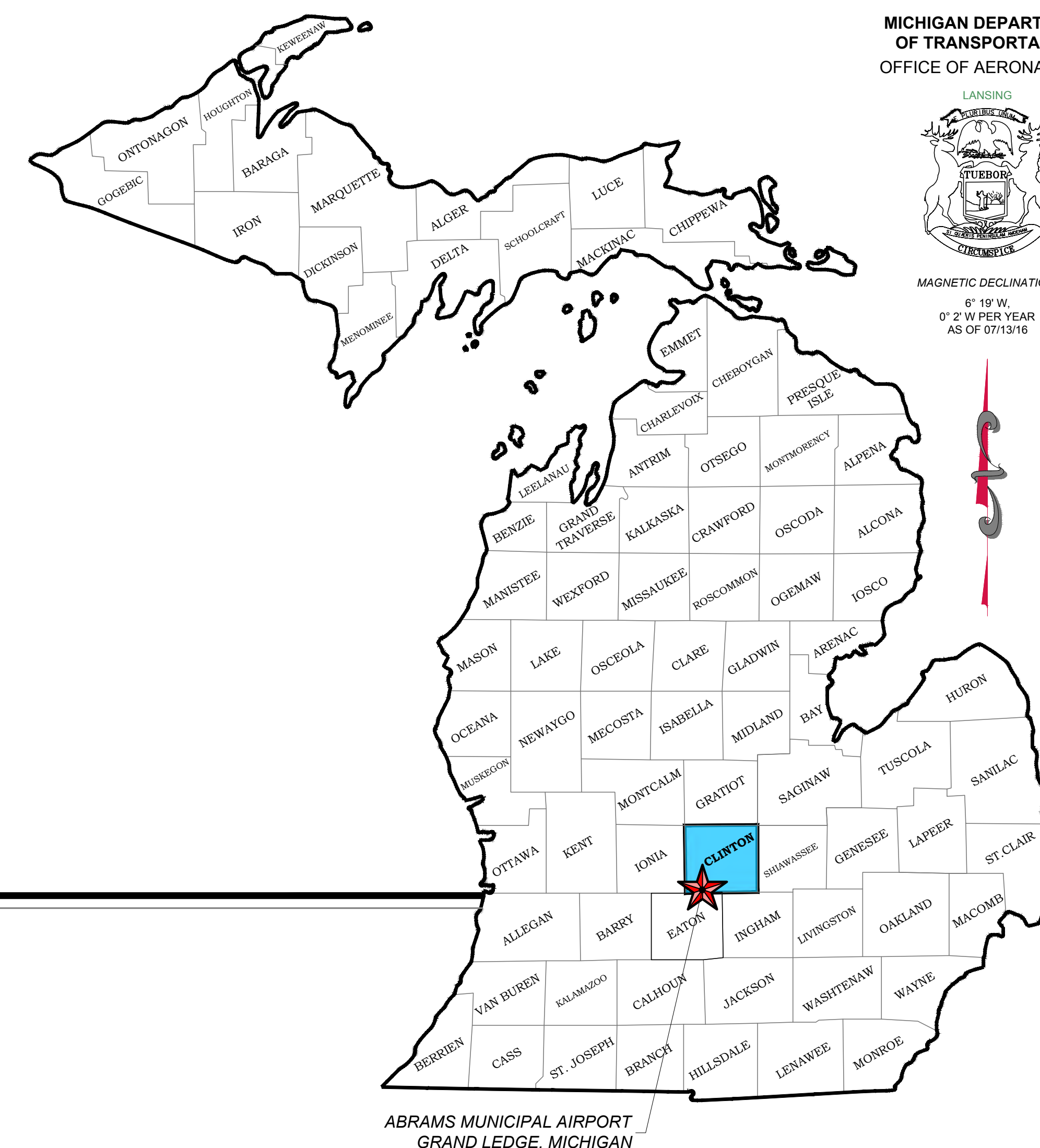
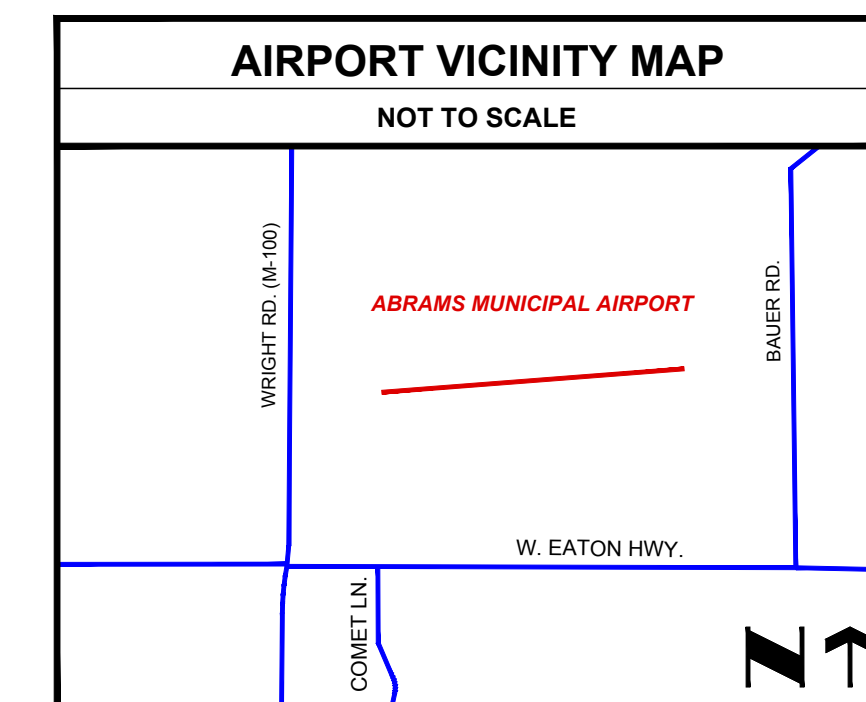
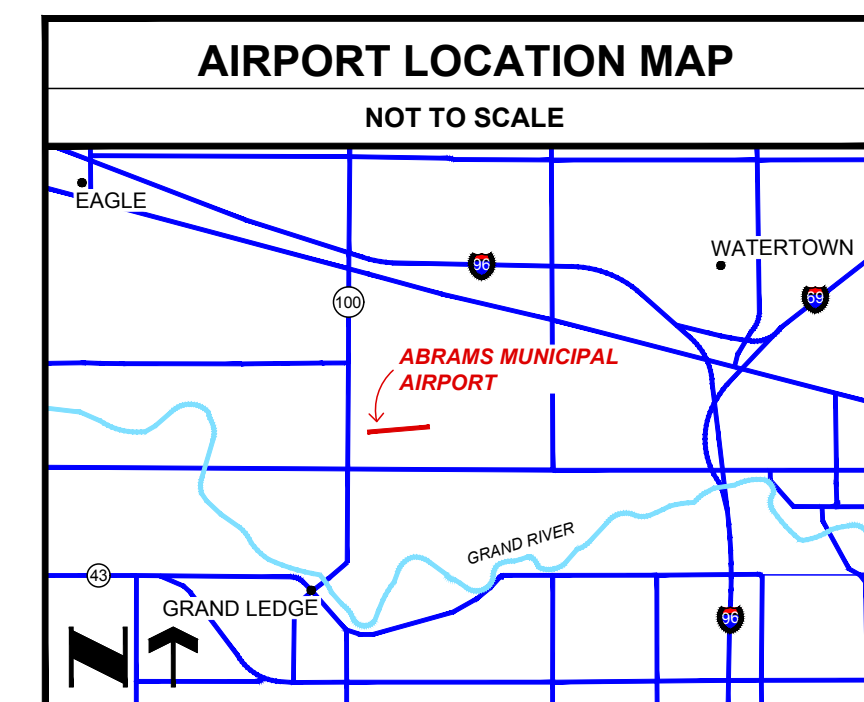

MICHIGAN DEPARTMENT  
OF TRANSPORTATION  
OFFICE OF AERONAUTICS

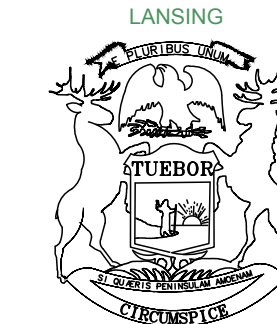

MAGNETIC DECLINATION:  
6° 19' W,  
0° 2' W PER YEAR  
AS OF 07/13/16

# ABRAMS MUNICIPAL AIRPORT

## GRAND LEDGE, MICHIGAN

### AIRPORT LAYOUT PLAN - NOVEMBER 2018

LOC-ID: 4D0 | STATE ID: 19-06

### LAST UPDATED JANUARY 2023

#### CITY OF GRAND LEDGE

APPROVED: *Adam Smith*  
ADAM SMITH  
CITY MANAGER / AIRPORT MANAGER

2/13/19  
DATE

APPROVED: *Amee King*  
AMEE KING  
ASSISTANT CITY ADMINISTRATOR

2/13/19  
DATE

#### CERTIFICATION

ON BEHALF OF MEAD & HUNT, INC. I CERTIFY THAT THE ALP PREPARED FOR ABRAMS MUNICIPAL AIRPORT WAS PREPARED ACCORDING TO THE APPLICABLE ADVISORY CIRCULARS. THE CURRENT VERSION OF THE GREAT LAKES REGION ALP CHECKLIST, AND ACCURATELY DEPICTS THE PROPOSED USE OF AIRSPACE AT THE TIME OF SUBMITTAL. THE ALP CONFORMS WITH FAA DESIGN STANDARDS, EXCEPT AS NOTED.



2605 PORT LANSING ROAD  
LANSING, MI 48906  
phone: 517.321.8334

APPROVED: *Stephanie A. D. Ward*  
STEPHANIE A. D. WARD, SENIOR PLANNER  
A.I.C.P. #014419

11/20/18  
DATE

#### INDEX OF SHEETS

SHEET NUMBER	SHEET NAME	REVISION DATE	SHEET NUMBER	SHEET NAME	REVISION DATE
1	TITLE SHEET	1/23			
2	DATA SHEET	1/23			
3	EXISTING AIRPORT LAYOUT PLAN	1/23			
4	FUTURE AIRPORT LAYOUT PLAN	1/23			
5	TERMINAL AREA PLAN	1/23			
6	AIRPORT AIRSPACE PLAN	1/23			
7	EXISTING RWY 9 INNER APPROACH SURFACE PLAN	1/23			
8	EXISTING RWY 27 INNER APPROACH SURFACE PLAN	1/23			
9	AERIAL PLAN	1/23			
10	PROPERTY PLAN	1/23			

AIP GRANT NO: 1913  
FEDERAL NO: B-26-0103-1913  
STATE ID: 19-06  
DATE: 6/16  
DESIGNED BY: AEF  
DRAWN BY: GAM  
CHECKED BY: SADW

DO NOT SCALE DRAWINGS

SHEET NO.

1 of 10

These documents shall not be used for any purpose or project for which it is not intended. Mead & Hunt shall be indemnified by the client and held harmless from all claims, damages, liabilities, losses, and expenses, including attorney's fees and costs, arising out of such misuse or reuse of the documents. In addition, unauthorized reproduction of these documents, in part or as a whole, is prohibited.

AIRPORT DATA TABLE	
ITEM	EXISTING
AIRPORT REFERENCE CODE (ARC)	B-II (SMALL AIRCRAFT)
MEAN MAX TEMPERATURE	82.4° (JULY)
AIRPORT ELEVATION	841'
AIRPORT NAVIGATIONAL AIDS	BEACON, SEGMENTED CIRCLE
AIRPORT REFERENCE POINT - LATITUDE	42° 46' 32.92" N
AIRPORT REFERENCE POINT - LONGITUDE	084° 43' 30.04" W
MISCELLANEOUS FACILITIES	LIGHTED WIND CONE
AIRPORT MAGNETIC DECLINATION	6° 19' W, MOVING 0° 2' W PER YEAR
NPIAS SERVICE LEVEL	GENERAL AVIATION
STATE EQUIVALENT SERVICE ROLE	GENERAL UTILITY

**NOTE:**  
1. THE NORTH MAGNETIC DECLINATION WAS CALCULATED ON 07/13/16, USING THE MOST RECENT WORLD MAGNETIC MODEL (WMM), EPOCH YEARS 2014-2019, FOUND AT [WWW.NGDC.NOAA.GOV/GEOMAG-WEBS/#DECLINATION](http://WWW.NGDC.NOAA.GOV/GEOMAG-WEBS/#DECLINATION). DECLINATION RESULTS ARE ACCURATE WITHIN A VARIANCE OF ± 0° 23' W.

DECLARED DISTANCES TABLE			
ABBR.	DESCRIPTION	RUNWAY 9/27	
		9	27
TORA	TAKE OFF RUN AVAILABLE	3,200'	3,200'
TODA	TAKE OFF DISTANCE AVAILABLE	3,200'	3,200'
ASDA	ACCELERATE STOP DISTANCE AVAILABLE	3,200'	3,200'
LDA	LANDING DISTANCE AVAILABLE	3,200'	3,200'

GLOSSARY OF ABBREVIATIONS	
ABBR.	ITEM
ARP	AIRPORT REFERENCE POINT
BRL	BUILDING RESTRICTION LINE
GPS	GLOBAL POSITIONING SYSTEM
LPV	LOCALIZER PERFORMANCE WITH VERTICAL GUIDANCE
MIRL	MEDIUM INTENSITY RUNWAY LIGHTS
MITL	MEDIUM INTENSITY TAXIWAY LIGHTS
PAPI	PRECISION APPROACH PATH INDICATOR
REIL	RUNWAY END IDENTIFIER LIGHTS
RWY	RUNWAY
TWY	TAXIWAY
VOR	VERY HIGH FREQUENCY OMNIDIRECTIONAL RANGE

SURVEY INFORMATION					
POINT	LATITUDE	LONGITUDE	EL.	STATION	OFFSET
NGS 1	42° 46' 32.84" N	084° 43' 27.15" W	839'	41+11	59' L
NGS 2	42° 46' 31.13" N	084° 43' 56.41" W	832.4'	19+21	64' L

**NOTE:**  
1. AT THIS AIRPORT THERE ARE NO PACS OR SACS.

RUNWAY DATA			
ABBR.	DESCRIPTION	RUNWAY 9/27	
		EXISTING	EXISTING
RDC	RUNWAY DESIGN CODE	B-II-5000	B-II-VIS
	CRITICAL AIRCRAFT	BEECH 58 <sup>1</sup>	BEECH 58 <sup>1</sup>
	PAVEMENT TYPE	ASPHALT	ASPHALT
	RUNWAY IDENTIFICATION	UTILITY	UTILITY
		SW - 25,000	SW - 25,000
	PAVEMENT STRENGTH BY WHEEL LOADING <sup>2</sup>	DW - N/A	DW - N/A
		DTW - N/A	DTW - N/A
	PAVEMENT STRENGTH BY PCN	N/A	N/A
	PAVEMENT SURFACE TREATMENT	N/A	N/A
	EFFECTIVE RUNWAY GRADIENT	0.30%	0.30%
	RUNWAY LENGTH	3200'	3200'
	RUNWAY WIDTH	75'	75'
EL	RUNWAY END ELEVATION	830.5'	840.2'
	RUNWAY END COORDINATE - LATITUDE <sup>3</sup>	42° 46' 31.02" N	42° 46' 33.45" N
	RUNWAY END COORDINATE - LONGITUDE <sup>3</sup>	084° 44' 09.46" W	084° 43' 26.68" W
	DISPLACED THRESHOLD	N/A	N/A
	DISPLACED THRESHOLD ELEVATION	N/A	N/A
	DISPLACED THRESHOLD COORDINATE - LATITUDE <sup>3</sup>	N/A	N/A
	DISPLACED THRESHOLD COORDINATE - LONGITUDE <sup>3</sup>	N/A	N/A
	RUNWAY LIGHTING TYPE	MIRL	MIRL
	RUNWAY MARKING TYPE	NON-PRECISION	NON-PRECISION
RSA	RUNWAY SAFETY AREA	300' x 150'	300' x 150'
RPZ	RUNWAY PROTECTION ZONE	250' x 450' x 1000'	250' x 450' x 1000'
ROFA	RUNWAY OBJECT FREE AREA	300' x 500'	300' x 500'
OFZ	RUNWAY OBSTACLE FREE ZONE	200' x 250'	200' x 250'
POFZ	RUNWAY PRECISION OBSTACLE FREE ZONE	N/A	N/A
	THRESHOLD SITING SURFACE CATEGORIES	CAT-4	CAT-4
TSS	THRESHOLD SITING SURFACE	400' x 3800' x 10,000'	400' x 3800' x 10,000'
	THRESHOLD SITING SURFACE SLOPE RATIO	20:1	20:1
AS	14 CFR PART 77 APPROACH SURFACE	500' x 2,000' x 5,000'	500' x 1250' x 5000' <sup>4</sup>
	14 CFR PART 77 APPROACH SURFACE TYPE	NON-PRECISION - A(NP)	VISUAL - A(V)
	14 CFR PART 77 APPROACH SURFACE SLOPE RATIO	20:1	20:1
	VISIBILITY MINIMUMS	NOT LOWER THAN 1 MI. 558' AGL - 1 MI. (LNAV)	VISUAL 558' AGL - 1 MI. (VOR)
	TYPE OF AERONAUTICAL APPROACH SURVEY	VERTICALLY GUIDED	NOT VERTICALLY GUIDED
DS	RUNWAY DEPARTURE SURFACE	N/A	N/A
	VISUAL AND INSTRUMENT NAVAIDS	PAPI	PAPI, REIL
TDZ	TOUCHDOWN ZONE ELEVATION	841.1'	841.1'
	TAXIWAY AND TAXILANE WIDTH	20', 25', 35'	20', 25', 35'
TSA	TAXIWAY AND TAXILANE SAFETY AREA	79'	79'
TOFA	TAXIWAY AND TAXILANE OBJECT FREE AREA	131'	131'
	TAXIWAY AND TAXILANE SEPARATION	240'	240'
	TAXIWAY AND TAXILANE LIGHTING	MITL	MITL
	HORIZONTAL DATUM	NAD83	NAD83
	VERTICAL DATUM	NAVDB8	NAVDB8

**NOTE:**  
(THE NOTES BELOW CORRESPOND TO THE NUMBERS ABOVE)  
1. THE AIRPORT HAS ACHIEVED B-II SAFETY STANDARDS, HOWEVER, THE CRITICAL AIRCRAFT FOR RUNWAY 9/27 IS B-I.  
2. EXISTING PAVEMENT STRENGTH SHOWN TAKES INTO CONSIDERATION WEIGHT OF MAINTENANCE EQUIPMENT AS WELL AS CRITICAL AIRCRAFT WEIGHT.  
3. EXISTING RUNWAY END COORDINATE INFORMATION (NAD83) TAKEN FROM AIRPORT 5010.  
4. THE EXISTING RWY 27 FAR PART-77 APPROACH SURFACE INNER WIDTH DIMENSION CORRESPONDS TO THE WIDTH OF THE PRIMARY SURFACE WHICH IS REGULATED BY THE RWY 9 FAR PART-77 APPROACH SURFACE.

**ADDITIONAL NOTE:**  
• THE WIDTHS OF THE RUNWAY SAFETY AREA (RSA), OBJECT FREE AREA (OFA) AND OBSTACLE FREE ZONE (OFZ) ARE CENTERED ON THE RUNWAY AND EXTEND THE ENTIRE LENGTH OF THE RUNWAY.  
• THERE ARE NO OFZ PENETRATIONS.  
• NO TSS PENETRATIONS.

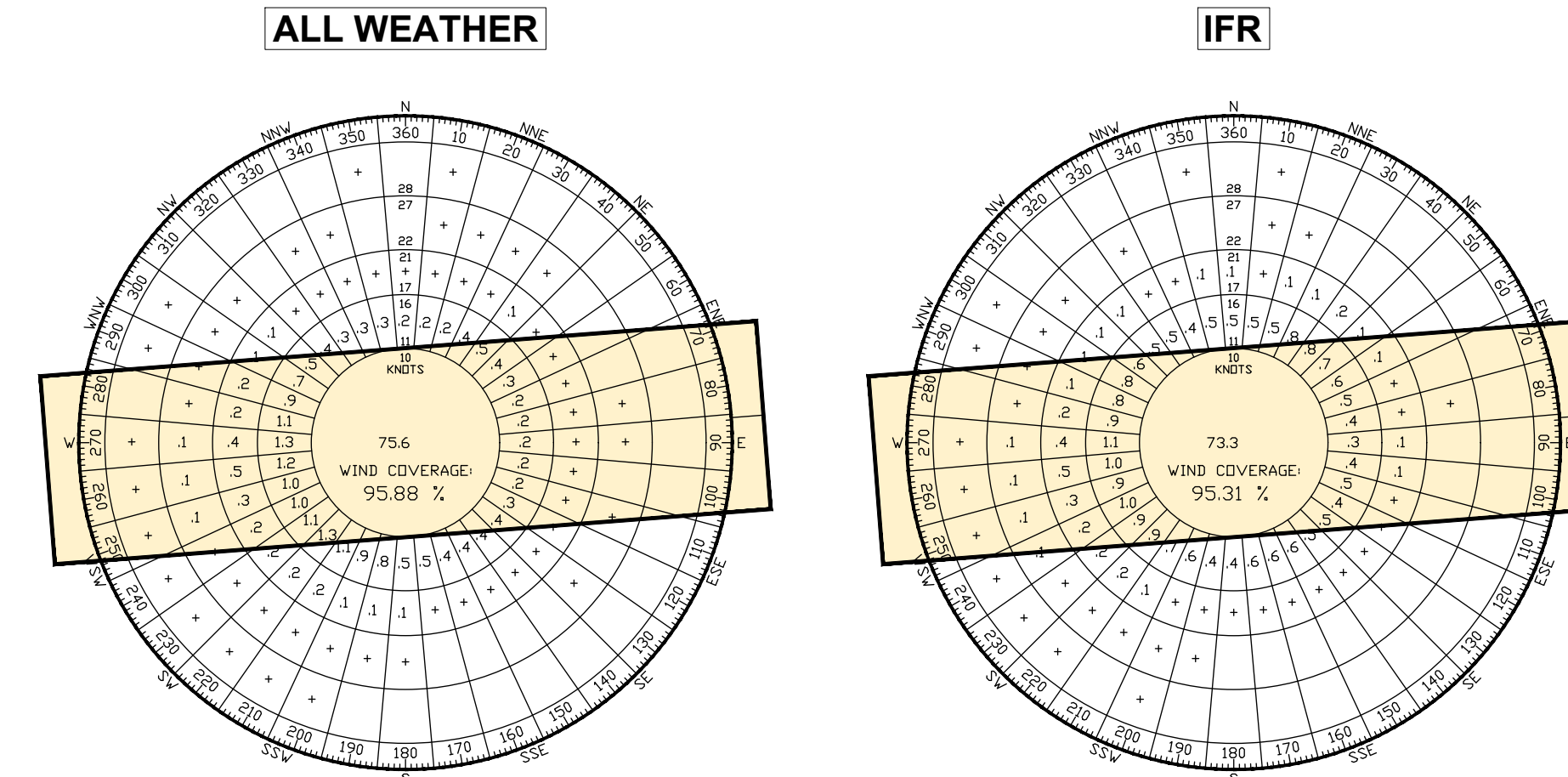

WIND COVERAGE TABLE				
RUNWAY	CROSSWIND			
	10.5 knots	13 knots	16 knots	20 knots
9-27	IFR			
	90.20%	95.31%	99.17%	99.86%
9-27	ALL WEATHER			
	91.36%	95.88%	99.18%	99.88%

**SOURCE**  
NATIONAL CLIMATIC DATA CENTER; FAA STANDARD WIND ANALYSIS TOOL

- STATION: CAPITAL CITY
- STATION NO: 725390
- NO. OF OBSERVATIONS: 128,433
- PERIOD OF RECORD: 2005-2014

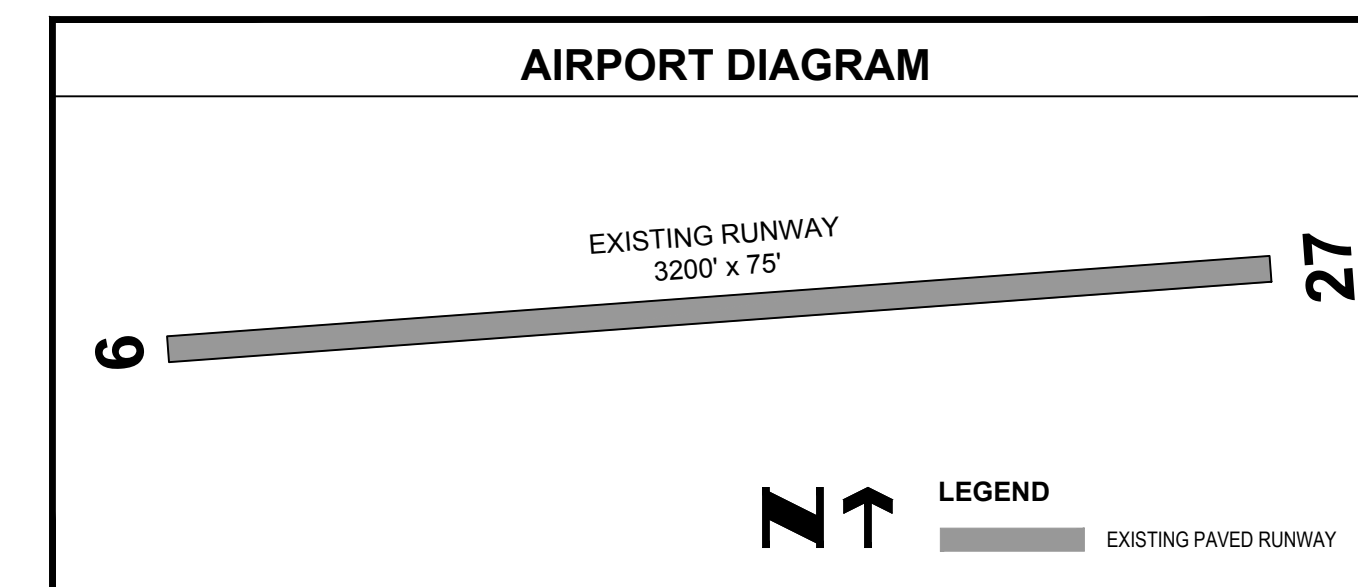

MODIFICATIONS TO STANDARDS			
APPROVAL DATE	AIRSPACE CASE NO.	STANDARD TO BE MODIFIED	DESCRIPTION
		NONE REQUIRED	

**ABRAMS MUNICIPAL AIRPORT**  
**AIRPORT LAYOUT PLAN**  
 GRAND LEDGE, MICHIGAN

REVISIONS		
1	DATE: 8/20	BY: MJF
RUNWAY REHABILITATION BA-26-0103-1913		
2	DATE: 1/23	BY: AEF
REMOVE EXISTING & FUTURE CROSSWIND RUNWAY 18/36		

MAH PROJ. NO: 071660-150857.01  
 FEDERAL NO: B-26-0103-1913  
 STATE ID: 19-06  
 DATE: 6/16  
 DESIGNED BY: AEF  
 DRAWN BY: GAM  
 CHECKED BY: SADW  
 DO NOT SCALE DRAWINGS

SHEET CONTENTS  
DATA SHEET

These documents shall not be used for any purpose or project for which it is not intended. Mead & Hunt shall be indemnified by the client and held harmless from all claims, damages, liabilities, losses, and expenses, including attorney's fees and costs, arising out of such reuse or use of the documents. In addition, unauthorized reproduction of these documents, in part or as a whole, is prohibited.

**ABRAMS MUNICIPAL AIRPORT  
AIRPORT LAYOUT PLAN**  
GRAND LEDGE, MICHIGAN

REVISIONS

1	DATE: 8/20	BY: MJF
1. RUNWAY REHABILITATION BA-26-0103-1913		
2	DATE: 12/22	BY: AEF
2. PARALLEL TAXIWAY & APRON REHABILITATION (F-26-0103-2421)		
3	DATE: 1/23	BY: AEF
3. REMOVE EXISTING & FUTURE CROSSWIND RUNWAY 18/36		

M&H PROJ. NO: 071660-150857.01  
FEDERAL NO: B-26-0103-1913  
STATE ID: 19-06  
DATE: 6/16  
DESIGNED BY: AEF  
DRAWN BY: GAM  
CHECKED BY: SADW  
DO NOT SCALE DRAWINGS

SHEET CONTENTS  
**EXISTING AIRPORT LAYOUT PLAN**

RUNWAY DATA			
ABBR.	DESCRIPTION	RUNWAY 9/27	
		9	27
	END COORDINATE - LATITUDE	42° 46' 31.02" N	42° 46' 33.45" N
	END COORDINATE - LONGITUDE	084° 44' 09.46" W	084° 43' 26.68" W
EL	ELEVATION	830.5'	840.2'
STA	STATION	9+50	41+49
	TRUE BEARING	N 85° 34' 43.72" W	N 85° 34' 43.72" W
	APPROACH TYPE	NON-PRECISION - A(NP)	VISUAL - A(V)
TDZ	TOUCHDOWN ZONE ELEVATION	841.1'	841.1'
	DISPLACED THRESHOLD - LATITUDE	N/A	N/A
	DISPLACED THRESHOLD - LONGITUDE	N/A	N/A
	DISPLACED THRESHOLD - ELEVATION	N/A	N/A

DECLARED DISTANCES TABLE			
ABBR.	DESCRIPTION	RUNWAY 9/27	
		9	27
TORA	TAKE OFF RUN AVAILABLE	3200'	3200'
TODA	TAKE OFF DISTANCE AVAILABLE	3200'	3200'
ASDA	ACCELERATE STOP DISTANCE AVAILABLE	3200'	3200'
LDA	LANDING DISTANCE AVAILABLE	3200'	3200'

BUILDING DATA TABLE		
ID.	DESCRIPTION	TOP EL.
A	ELECTRICAL VAULT	841'
B	TERMINAL BUILDING	845'
C	HANGAR	849'
D	HANGAR	849'
E	HANGAR	849'
F	T-HANGAR	851'
G	BOX HANGAR	849'
H	MI NATIONAL GUARD HANGAR	847'
I	T-HANGAR	855'
J	BOX HANGAR	858'
K	BOX HANGAR	857'
L	BOX HANGAR	858'
M	BOX HANGAR	858'
N	BOX HANGAR	860'
O	MEETING SPACE	857'

NOTE:  
1. TOP ELEVATION IS IN 'AMSL' OR 'ABOVE MEAN SEA LEVEL'.  
2. BUILDING 'D' AND 'E' HAVE BEEN DEMOLISHED.

RUNWAY SAFETY AREAS			
ABBR.	DESCRIPTION	RUNWAY 9/27	
		9	27
RPZ	RUNWAY PROTECTION ZONE	250' x 450' x 1000'	250' x 450' x 1000'
RSA	RUNWAY SAFETY AREA	300' x 150'	300' x 150'
ROFA	RUNWAY OBJECT FREE AREA	300' x 500'	300' x 500'
OFZ	OBSTACLE FREE ZONE	200' x 250'	200' x 250'
POFZ	PRECISION OBSTACLE FREE ZONE	N/A	N/A
AS	FAR PART-77 APPROACH SURFACE	500' x 2,000' x 5,000'	500' x 1250' x 5000'²
	THRESHOLD SITING SURFACE CATEGORY	CAT-4	CAT-4
TSS	THRESHOLD SITING SURFACE DIMENSION	400' x 3800' x 10,000'²	400' x 3800' x 10,000'²
	THRESHOLD SITING SURFACE SLOPE	20:1	20:1

NOTE:  
1. RUNWAY SAFETY AREAS (RSA, ROFA, OFZ) RUN THE ENTIRE LENGTH OF THE RUNWAY WHILE THE DIMENSIONS SHOWN ARE FOR LENGTHS BEYOND THE RUNWAY END.  
2. THE EXISTING RWY 27 FAR PART-77 APPROACH SURFACE INNER WIDTH DIMENSION CORRESPONDS TO THE WIDTH OF THE PRIMARY SURFACE WHICH IS REGULATED BY THE RWY 9 FAR PART-77 APPROACH SURFACE.  
3. THE 200' OFFSET OF THE THRESHOLD SITING SURFACE TO BE AVOIDED DUE TO THE USE OF A VISUAL GUIDANCE SLOPE INDICATOR (VGS) AS PER NOTE 1 TO TABLE 3-2 OF THE FAA AC 150/5300-13A.

RUNWAY DIMENSIONAL INFORMATION			
ABBR.	DESCRIPTION	RUNWAY 9/27	
		9	27
	EXISTING		
RWY	RUNWAY LENGTH	3200'	3200'
	RUNWAY WIDTH	75'	75'
	RUNWAY SHOULDER WIDTH	10'	10'
TDG	TAXIWAY DESIGN GROUP	2	2
TWY	TAXIWAY WIDTH	20', 25', 35'	20', 25', 35'
TLN	TAXILANE WIDTH	20'	20'
TESM	TAXIWAY EDGE SAFETY MARGIN	7.5'	7.5'
	TAXIWAY SHOULDER WIDTH	15'	15'
TSA	TAXIWAY SAFETY AREA WIDTH	79'	79'
TOFA	TAXIWAY OBJECT FREE AREA WIDTH	131'	131'
	TAXILANE OBJECT FREE AREA WIDTH	115'	115'
	RWY CLINE TO TWY HOLD LINE	125'	125'
	RWY CLINE TO TWY CLINE	240'	240'
BRL	RWY CLINE TO BUILDING RESTRICTION LINE	495'	495'

NOTE:  
1. THE LOCATION OF THE 'BRL' IS DEPENDENT UPON THE SELECTED ALLOWABLE STRUCTURE HEIGHT WHICH IS 35 FEET.

AIRPORT REFERENCE POINT (A.R.P.)		
ABBR.	DESCRIPTION	EXISTING
LAT.	LATITUDE	42° 46' 32.92" N
LONG.	LONGITUDE	084° 43' 30.04" W
EL.	ELEVATION	841'

SURVEY INFORMATION					
POINT	LATITUDE	LONGITUDE	EL.	STATION	OFFSET
NGS 1	42° 46' 32.84" N	084° 43' 27.15" W	839'	41+11	59' L
NGS 2	42° 46' 31.13" N	084° 43' 56.41" W	832.4'	19+21	64' L

NOTE:  
1. AT THIS AIRPORT THERE ARE NO PACS OR SACS.

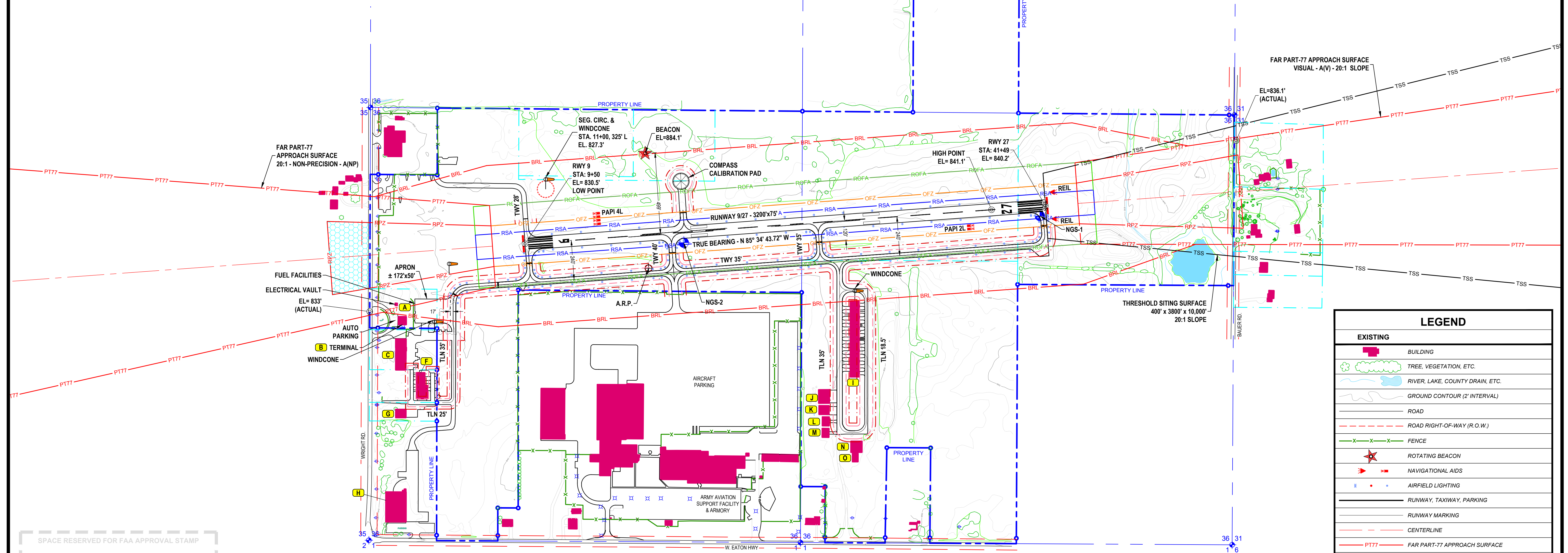

LEGEND	
<b>EXISTING</b>	
	BUILDING
	TREE, VEGETATION, ETC.
	RIVER, LAKE, COUNTY DRAIN, ETC.
	GROUND CONTOUR (2' INTERVAL)
	ROAD
	ROAD RIGHT-OF-WAY (R.O.W.)
	FENCE
	ROTATING BEACON
	NAVIGATIONAL AIDS
	AIRFIELD LIGHTING
	RUNWAY, TAXIWAY, PARKING
	RUNWAY MARKING
	CENTERLINE
	FAR PART-77 APPROACH SURFACE
	RUNWAY PROTECTION ZONE
	RUNWAY SAFETY AREA
	RUNWAY OBJECT FREE AREA
	OBSTACLE FREE ZONE
	BUILDING RESTRICTION LINE
	THRESHOLD SITING SURFACE
	TAXIWAY SAFETY AREA
	TAXIWAY OBJECT FREE AREA
	AIRPORT PROPERTY LINE
	PROPERTY PARCEL
	SECTION LINE
	AVIGATION EASEMENT

**GENERAL NOTES:**

- AIRPORT PROPERTY IS LOCATED WITHIN SECTION 25 OF GRAND LEDGE TOWNSHIP, CLINTON COUNTY (T.7S,R.17W.) AND SECTION 30 OF EAGLE TOWNSHIP, CLINTON COUNTY (T.7S,R.16W).
- BASE INFORMATION, INCLUDING AERIAL, PROVIDED BY QUANTUM SPATIAL (JULY 2015) AND SUPPLEMENTED WITH FIELD SURVEY DATA PROVIDED BY MEAD & HUNT, INC. WHERE NECESSARY.
- THE NORTH MAGNETIC DECLINATION WAS CALCULATED ON 07/13/16, USING THE MOST RECENT WORLD MAGNETIC MODEL (WMM), EPOCH YEARS 2014-2019, FOUND AT [WWW.NGDC.NOAA.GOV/GEOMAG-WEB/](http://WWW.NGDC.NOAA.GOV/GEOMAG-WEB/) #DECLINATION. DECLINATION RESULTS ARE ACCURATE WITHIN A VARIANCE OF ± 0' 23" W.
- RUNWAY COORDINATES TAKEN FROM AIRPORT 5010.
- ADDITIONAL INFORMATION RELATED TO THE TERMINAL AND HANGAR DEVELOPMENT AREAS, TAXILANES, HOLD LINES, AND BUILDINGS CAN BE FOUND ON THE "TERMINAL AREA PLAN" SHEET.
- FENCE SURROUNDING THE AIRPORT IS COMPOSED OF A 6' CHAIN LINKED FENCE SURROUNDING THE NORTHWEST CORNER OF THE AIRPORT PROPERTY LINE, A 4' WOODEN FENCE ALONG THE WESTERN PROPERTY LINE AND AROUND THE TERMINAL AREA, AND A 5' CHAIN LINK GATE ALONG THE SOUTHERN PROPERTY LINE LEADING INTO THE AIRPORT JUST EAST OF THE MICHIGAN NATIONAL GUARD AREA.
- APRONS MAY VARY IN SHAPE, THEREFORE, THE SIZE SHOWN IS CALCULATED FROM POINTS THAT MAKE UP THE LARGEST RECTANGULAR SHAPE FOR EACH AREA.
- DISTANCE FROM TAXIWAY CENTERLINE TO AIRCRAFT PARKING IS THE SAME AS THE TAXIWAY OBJECT FREE AREA DIMENSION UNLESS OTHERWISE SHOWN.
- THERE ARE NO SPECIAL USE AREAS (I.E., AGRICULTURAL SPRAYING, DEICING/CONTAINMENT).
- RUNWAY 9/27 WAS REHABILITATED IN 2019 AND THE GROUND CONTOUR LINES SHOWN ALONG THE RUNWAY ARE FROM BEFORE THAT PROJECT. CONTOUR LINES MAY NOT REFLECT ACTUAL GROUND CONTOURS.

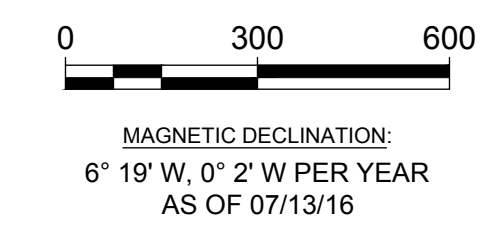

SPACE RESERVED FOR FAA APPROVAL STAMP

These documents shall not be used for any purpose or project for which it is not intended. Mead & Hunt shall be indemnified by the client and held harmless from all claims, damages, liabilities, losses, and expenses, including attorney's fees and costs, arising out of such reuse or reuse of the documents. In addition, unauthorized reproduction of these documents, in part or as a whole, is prohibited.

BUILDING DATA TABLE		
ID.	DESCRIPTION	TOP EL.
A	ELECTRICAL VAULT	841'
B	TERMINAL BUILDING	845'
C	HANGAR	849'
D	T-HANGAR	854'
E	T-HANGAR	842'
F	T-HANGAR	851'
G	BOX HANGAR	849'
H	MI NATIONAL GUARD HANGAR	847'
I	T-HANGAR	855'
J	BOX HANGAR	858'
K	BOX HANGAR	857'
L	BOX HANGAR	858'
M	BOX HANGAR	858'
N	BOX HANGAR	860'
O	MEETING SPACE	857'

**NOTE:**  
1. TOP ELEVATION IS IN 'AMSL' OR 'ABOVE MEAN SEA LEVEL'.  
2. BUILDING 'D' AND 'E' HAVE BEEN DEMOLISHED.

RUNWAY DIMENSIONAL INFORMATION			
ABBR.	DESCRIPTION	RUNWAY 9/27	
		EXISTING	27
RWY	RUNWAY LENGTH	3200'	3200'
	RUNWAY WIDTH	75'	75'
	RUNWAY SHOULDER WIDTH	10'	10'
TDG	TAXIWAY DESIGN GROUP	2	2
TWY	TAXIWAY WIDTH	20', 25', 35'	20', 25', 35'
TLN	TAXILANE WIDTH	20'	20'
TESM	TAXIWAY EDGE SAFETY MARGIN	7.5'	7.5'
	TAXIWAY SHOULDER WIDTH	15'	15'
TSA	TAXIWAY SAFETY AREA WIDTH	79'	79'
TOFA	TAXIWAY OBJECT FREE AREA WIDTH	131'	131'
	TAXILANE OBJECT FREE AREA WIDTH	115'	115'
	RWY CLINE TO TWY HOLD LINE	125'	125'
	RWY CLINE TO TWY CLINE	240'	240'
BRL	RWY CLINE TO BUILDING RESTRICTION LINE	495'	495'

**NOTE:**  
1. THE LOCATION OF THE "BRL" IS DEPENDENT UPON THE SELECTED ALLOWABLE STRUCTURE HEIGHT WHICH IS 35 FEET.

RUNWAY DATA			
ABBR.	DESCRIPTION	RUNWAY 9/27	
		EXISTING	27
	END COORDINATE - LATITUDE	42° 46' 31.02" N	42° 46' 33.45" N
	END COORDINATE - LONGITUDE	084° 44' 09.46" W	084° 43' 26.68" W
EL	ELEVATION	830.5'	840.2'
STA	STATION	9+50	41+49
	TRUE BEARING	N 85° 34' 43.72" W	N 85° 34' 43.72" W
	APPROACH TYPE	NON-PRECISION - A(NP)	VISUAL - A(V)
TDZ	TOUCHDOWN ZONE ELEVATION	841.1'	841.1'
	DISPLACED THRESHOLD - LATITUDE	N/A	N/A
	DISPLACED THRESHOLD - LONGITUDE	N/A	N/A
	DISPLACED THRESHOLD - ELEVATION	N/A	N/A

SURVEY INFORMATION					
POINT	LATITUDE	LONGITUDE	EL.	STATION	OFFSET
NGS 1	42° 46' 32.84" N	084° 43' 27.15" W	839'	41+87	59.3' L
NGS 2	42° 46' 31.13" N	084° 43' 56.41" W	832.4'	19+21	63.7' L

**NOTE:**  
1. AT THIS AIRPORT THERE ARE NO PACS OR SACS.

RUNWAY SAFETY AREAS			
ABBR.	DESCRIPTION	RUNWAY 9/27	
		EXISTING	27
RPZ	RUNWAY PROTECTION ZONE	250' x 450' x 1000'	250' x 450' x 1000'
RSA	RUNWAY SAFETY AREA	300' x 150'	300' x 150'
ROFA	RUNWAY OBJECT FREE AREA	300' x 500'	300' x 500'
OFZ	OBSTACLE FREE ZONE	200' x 250'	200' x 250'
POFZ	PRECISION OBSTACLE FREE ZONE	N/A	N/A
AS	FAR PART-77 APPROACH SURFACE	500' x 2,000' x 5,000'	500' x 1250' x 5000'
	THRESHOLD SITING SURFACE CATEGORY	CAT-4	CAT-4
TSS	THRESHOLD SITING SURFACE DIMENSION	400' x 3800' x 10,000'	400' x 3800' x 10,000'
	THRESHOLD SITING SURFACE SLOPE	20:1	20:1

**NOTE:**  
1. RUNWAY SAFETY AREAS (RSA, ROFA, OFZ) RUN THE ENTIRE LENGTH OF THE RUNWAY WHILE THE DIMENSIONS SHOWN ARE FOR LENGTHS BEYOND THE RUNWAY END.  
2. THE EXISTING RWY 27 FAR PART-77 APPROACH SURFACE INNER WIDTH DIMENSION CORRESPONDS TO THE WIDTH OF THE PRIMARY SURFACE WHICH IS REGULATED BY THE RWY 9 FAR PART-77 APPROACH SURFACE.  
3. THE 200' OFFSET OF THE THRESHOLD SITING SURFACE TO BE AVOIDED DUE TO THE USE OF A VISUAL GUIDANCE SLOPE INDICATOR (VGS) AS PER NOTE 1 TO TABLE 3-2 OF THE FAA AC 150/5300-13A.

DECLARED DISTANCES TABLE			
ABBR.	DESCRIPTION	RUNWAY 9/27	
		EXISTING	27
TORA	TAKE OFF RUN AVAILABLE	3,200'	3,200'
TODA	TAKE OFF DISTANCE AVAILABLE	3,200'	3,200'
ASDA	ACCELERATE STOP DISTANCE AVAILABLE	3,200'	3,200'
LDA	LANDING DISTANCE AVAILABLE	3,200'	3,200'

AIRPORT REFERENCE POINT (A.R.P.)		
ABBR.	DESCRIPTION	EXISTING
LAT.	LATITUDE	42° 46' 32.92" N
LONG.	LONGITUDE	084° 43' 30.04" W
EL.	ELEVATION	841'

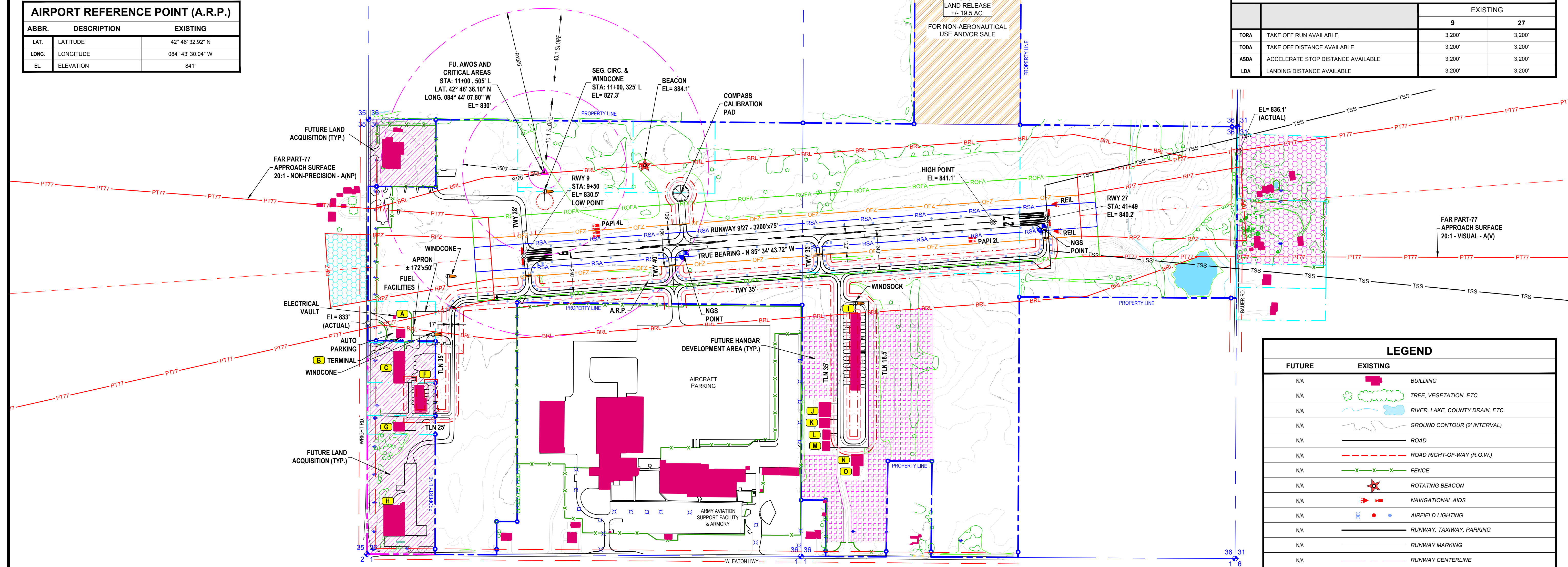

LEGEND		
FUTURE	EXISTING	
N/A	[Pink Box]	BUILDING
N/A	[Green Dotted Box]	TREE, VEGETATION, ETC.
N/A	[Blue Wavy Line]	RIVER, LAKE, COUNTY DRAIN, ETC.
N/A	[Brown Dotted Box]	GROUND CONTOUR (2' INTERVAL)
N/A	[Black Line]	ROAD
N/A	[Red Dashed Line]	ROAD RIGHT-OF-WAY (R.O.W.)
N/A	[Green X-X-X Line]	FENCE
N/A	[Red Star]	ROTATING BEACON
N/A	[Red Arrow]	NAVIGATIONAL AIDS
N/A	[Blue Dotted Box]	AIRFIELD LIGHTING
N/A	[Black Line]	RUNWAY, TAXIWAY, PARKING
N/A	[Black Dotted Line]	RUNWAY MARKING
N/A	[Red Dashed Line]	RUNWAY CENTERLINE
N/A	[Red Dashed Line]	FAR PART-77 APPROACH SURFACE
N/A	[Red Dashed Line]	RPZ - RUNWAY PROTECTION ZONE
N/A	[Blue Dashed Line]	RSA - RUNWAY SAFETY AREA
N/A	[Green Dashed Line]	ROFA - RUNWAY OBJECT FREE AREA
N/A	[Orange Dashed Line]	OFZ - OBSTACLE FREE ZONE
N/A	[Red Dashed Line]	BRL - BUILDING RESTRICTION LINE
N/A	[Red Dashed Line]	TAXIWAY SAFETY AREA
N/A	[Red Dashed Line]	TAXIWAY OBJECT FREE AREA
N/A	[Blue Dashed Line]	AIRPORT PROPERTY LINE
N/A	[Blue Dashed Line]	PROPERTY PARCEL
N/A	[Blue Dashed Line]	SECTION LINE
[Blue Dotted Box]	[Blue Dotted Box]	AVIGATION EASEMENT
[Pink Dotted Box]	[Pink Dotted Box]	FEE ACQUISITION
[Red Dotted Box]	[Red Dotted Box]	TO BE REMOVED
[Blue Dotted Box]	[Blue Dotted Box]	FUTURE AERONAUTICAL DEVELOPMENT
[Orange Dotted Box]	[Orange Dotted Box]	FUTURE LAND RELEASE

- GENERAL NOTES:**
- AIRPORT PROPERTY IS LOCATED WITHIN SECTION 25 OF GRAND LEDGE TOWNSHIP, CLINTON COUNTY (T.7S.R.17W.) AND SECTION 30 OF EAGLE TOWNSHIP, CLINTON COUNTY (T.7S.R.16W).
  - BASE INFORMATION, INCLUDING AERIAL, PROVIDED BY QUANTUM SPATIAL (JULY 2015) AND SUPPLEMENTED WITH FIELD SURVEY DATA PROVIDED BY MEAD & HUNT, INC. WHERE NECESSARY.
  - THE NORTH MAGNETIC DECLINATION WAS CALCULATED ON 07/13/16, USING THE MOST RECENT WORLD MAGNETIC MODEL (WMM), EPOCH YEARS 2014-2019, FOUND AT WWW.NGDC.NOAA.GOV/GOMAG-WEB/#DECLINATION. DECLINATION RESULTS ARE ACCURATE WITHIN A VARIANCE OF ± 0" 23" W.
  - RUNWAY COORDINATES TAKEN FROM AIRPORT 5010.
  - ADDITIONAL INFORMATION RELATED TO THE TERMINAL AND HANGAR DEVELOPMENT AREAS, TAXILANES, HOLD LINES, AND BUILDINGS CAN BE FOUND ON THE "TERMINAL AREA PLAN" SHEET.
  - FENCE SURROUNDING THE AIRPORT IS COMPOSED OF A 6' CHAIN LINKED FENCE SURROUNDING THE NORTHWEST CORNER OF THE AIRPORT PROPERTY LINE, A 4' WOODEN FENCE ALONG THE WESTERN PROPERTY LINE AND AROUND THE TERMINAL AREA, AND A 5' CHAIN LINK GATE ALONG THE SOUTHERN PROPERTY LINE LEADING INTO THE AIRPORT JUST EAST OF THE MICHIGAN NATIONAL GUARD AREA.
  - APRONS MAY VARY IN SHAPE, THEREFORE, THE SIZE SHOWN IS CALCULATED FROM POINTS THAT MAKE UP THE LARGEST RECTANGULAR SHAPE FOR EACH AREA.
  - DISTANCE FROM TAXIWAY CENTERLINE TO AIRCRAFT PARKING IS THE SAME AS THE TAXIWAY OBJECT FREE AREA DIMENSION UNLESS OTHERWISE SHOWN.
  - THERE ARE NO SPECIAL USE AREAS (I.E., AGRICULTURAL SPRAYING, DEICING/CONTAMINANT).
  - RUNWAY 9/27 WAS REHABILITATED IN 2019 AND THE GROUND CONTOUR LINES SHOWN ALONG THE RUNWAY ARE FROM BEFORE THAT PROJECT. CONTOUR LINES MAY NOT REFLECT ACTUAL GROUND CONDITIONS.

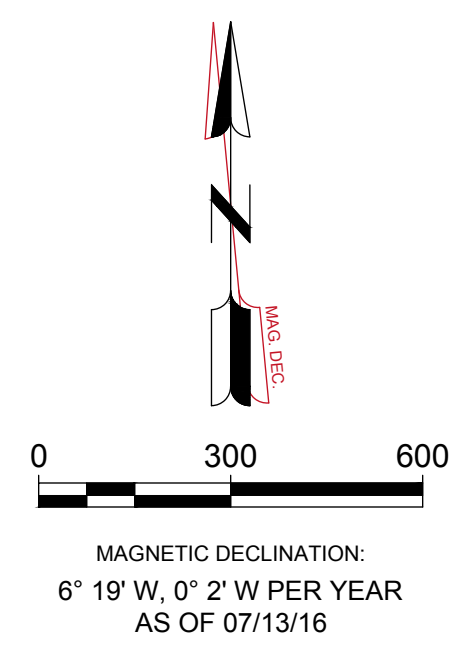

**ABRAMS MUNICIPAL AIRPORT  
AIRPORT LAYOUT PLAN**  
GRAND LEDGE, MICHIGAN

REVISIONS

1	DATE: 8/20	BY: MJF
RUNWAY REHABILITATION BA-26-0103-1913		
2	DATE: 9/22	BY: AEF
PARALLEL TAXIWAY & APRON REHABILITATION (F-26-0103-2421)		
3	DATE: 1/23	BY: AEF
REMOVE EXISTING & FUTURE CROSSWIND RUNWAY 18/36		

M&H PROJ. NO: 071660-150857.01  
FEDERAL NO: B-26-0103-1913  
STATE ID: 19-06  
DATE: 6/16  
DESIGNED BY: AEF  
DRAWN BY: GAM  
CHECKED BY: SADW  
DO NOT SCALE DRAWINGS

X:\071660\201608\0117\170624\1913\_BA-26-0103-1913.dwg  
11/02/2016 4:37:38 PM



These documents shall not be used for any purpose or project for which it is not intended. Mead & Hunt shall be indemnified by the client and held harmless from all claims, damages, liabilities, losses, and expenses, including attorney's fees and costs, arising out of such misuse or reuse of the documents. In addition, unauthorized reproduction of these documents, in part or as a whole, is prohibited.

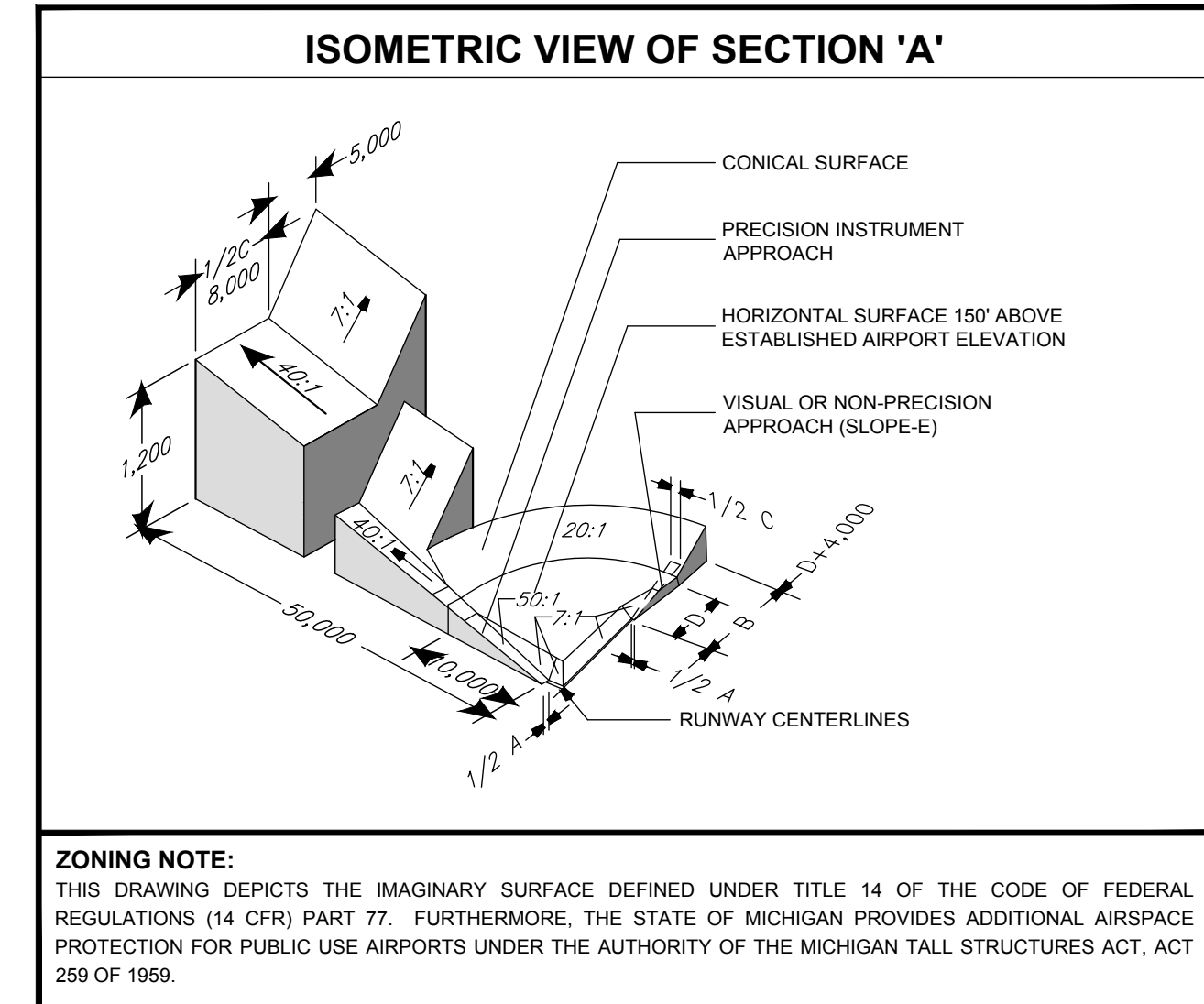
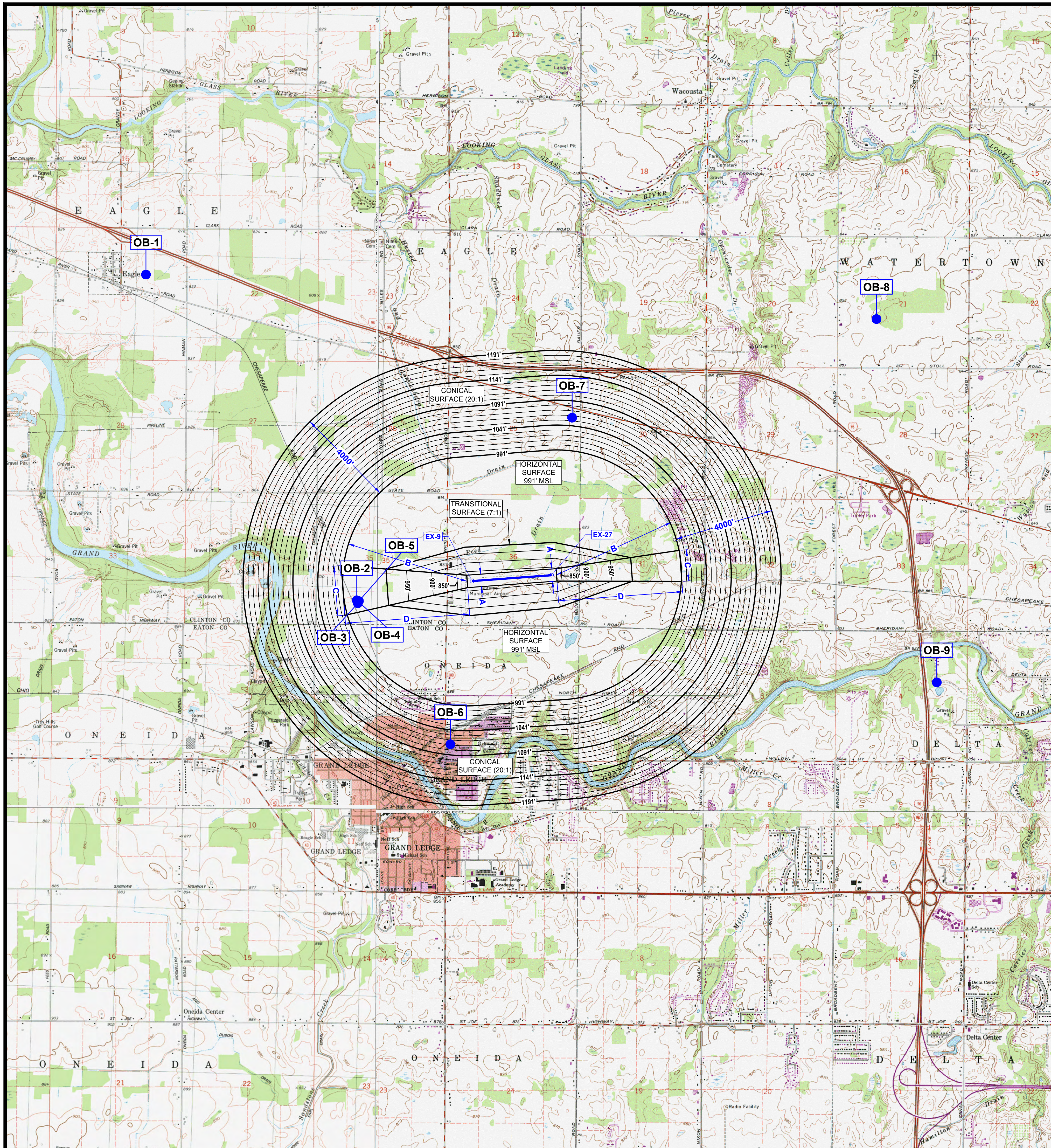

**OBJECT DATA TABLE**

OBJECT	TYPE	LATITUDE	LONGITUDE	AGL	AMSL	PENETRATION	DISPOSITION	ASN NUMBER
OB-1	TOWER	42° 48' 32.00" N	84° 47' 06.00" W	267'	1,106'	N/A	DONH	1997-AGL-405-OE
OB-2	OTHER WITHOUT ANTENNA	42° 46' 23.19" N	84° 45' 11.68" W	153'	992'	1'	LIGHTED	2010-AGL-2900-OE
OB-3	ELEVATOR	42° 46' 22.00" N	84° 45' 11.00" W	162'	997'	6'	LIGHTED	26-01040
OB-4	OTHER WITHOUT ANTENNA	42° 46' 22.62" N	84° 45' 10.65" W	190'	1,025'	34'	LIGHTED	2001-AGL-2907-OE
OB-5	GRAN ELEVATOR	42° 46' 22.87" N	84° 45' 10.43" W	165'	1,004'	13'	LIGHTED	26-021636
OB-6	TOWER	42° 45' 26.24" N	84° 44' 20.80" W	179'	1,011'	20'	LIGHTED	26-001330
OB-7	OTHER WITHOUT ANTENNA	42° 47' 36.00" N	84° 43' 16.00" W	140'	992'	64'	LIGHTED	198-AGL-3649-OE
OB-8	OTHER WITHOUT ANTENNA	42° 48' 15.60" N	84° 40' 32.00" W	240'	1,100'	N/A	DONH	1999-AGL-2303-OE
OB-9	TOWER	42° 45' 51.56" N	84° 39' 59.00" W	254'	1,081'	N/A	DONH	2003-AGL-6945-OE

**NOTE:**  
1. 'AGL' STANDS FOR 'ABOVE GROUND LEVEL'.  
2. 'AMSL' STANDS FOR 'ABOVE MEAN SEA LEVEL'.  
3. OBJECTS SHOWN ARE NOT AN INCLUSIVE LIST DUE TO CONTINUAL CONSTRUCTION OF TOWERS AND TALL STRUCTURES. PLEASE CONSULT FAA AND MDOT OFFICE OF AERONAUTICS FOR ADDITIONAL INFORMATION.

**APPROACH SURFACE DIMENSIONS**

LABEL	ITEM	RUNWAY 9/27	
		EXISTING	
		9	27
A	WIDTH OF PRIMARY SURFACE	500'	500'
B	RADIUS OF HORIZONTAL SURFACE	5,000'	5,000'
C	APPROACH SURFACE OUTER WIDTH	2,000'	2,000'
D	APPROACH SURFACE LENGTH	5,000'	5,000'
E	APPROACH SURFACE RATIO	20:1	20:1

**NOTE:**  
1. THE EXISTING RWY 27 FAR PART-77 APPROACH SURFACE INNER WIDTH DIMENSION CORRESPONDS TO THE WIDTH OF THE PRIMARY SURFACE WHICH IS REGULATED BY THE RWY 9 FAR PART-77 APPROACH SURFACE.

**GENERAL NOTES**

- ANY OBJECTS SHOWN ARE LOCATED WITH THE USE OF "OBSTRUCTION EVALUATION" DATA PROVIDED BY MDOT OFFICE OF AERONAUTICS DATED JANUARY 2016. THE CURRENT FILE CONTAINS ALL APPLICATIONS RECEIVED SINCE 1996.
- MEAD & HUNT AND MDOT OFFICE OF AERONAUTICS ARE NOT RESPONSIBLE FOR THE ACCURACY OF THE NOAA DATABASE. THE DATABASE MAY NOT BE INCLUSIVE OF ALL OBSTACLES WITHIN THE PART-77 SURFACES SHOWN.
- SECTIONAL CHARTS & THE FAA SHOULD BE REFERENCED FOR ADDITIONAL INFORMATION DUE TO THE CONTINUED PROLIFERATION OF TOWERS AND ASSOCIATED OBSTACLES.

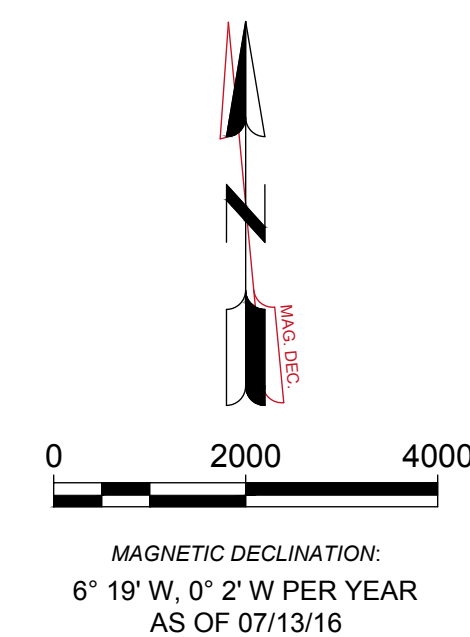

**ABRAMS MUNICIPAL AIRPORT  
AIRPORT LAYOUT PLAN**  
GRAND LEDGE, MICHIGAN

REVISIONS  
1 DATE: 1/23 BY: AEF  
REMOVE EXISTING & FUTURE  
CROSSWIND RUNWAY 18/36

MAH PROJ. NO: 071660-150857.01  
FEDERAL NO: B-26-0103-1913  
STATE ID: 19-06  
DATE: 6/16  
DESIGNED BY: AEF  
DRAWN BY: GAM  
CHECKED BY: SADW  
DO NOT SCALE DRAWINGS

SHEET CONTENTS  
**AIRPORT AIRSPACE  
PLAN**

**PLAN AND PROFILE - RUNWAY 9 END**

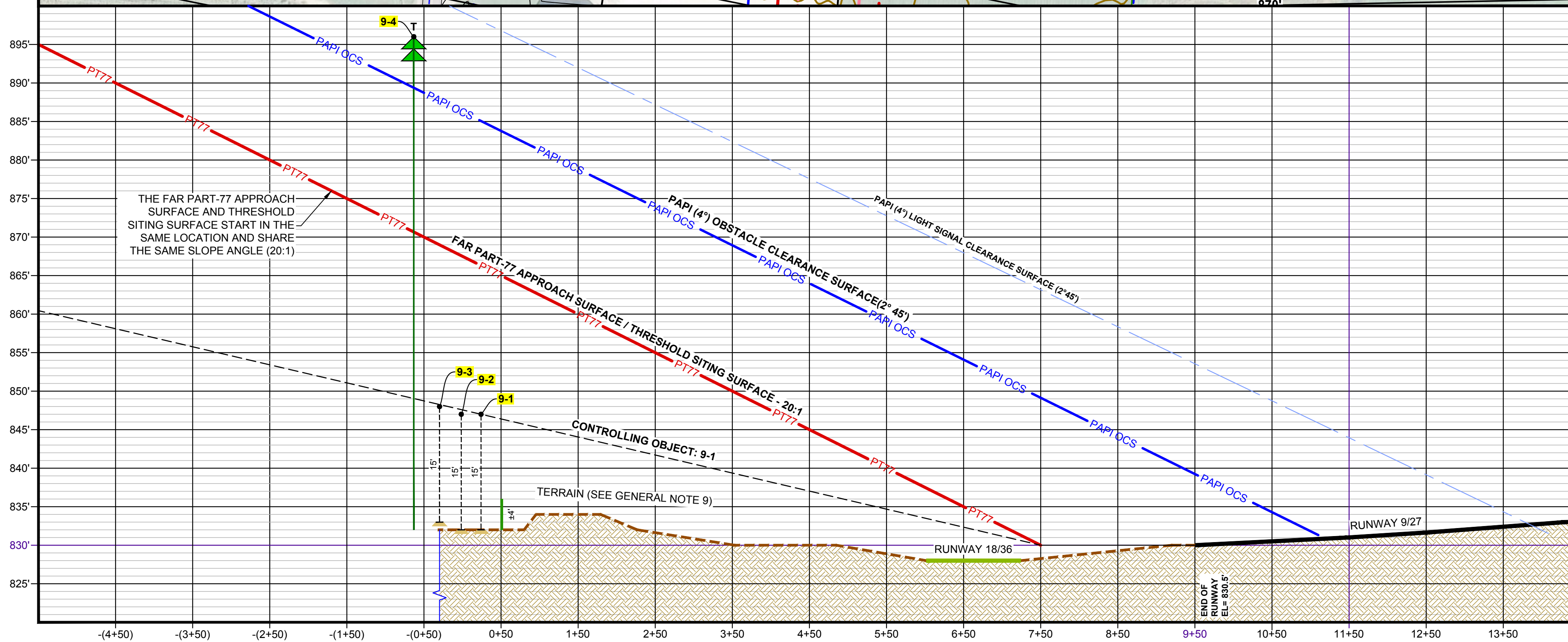
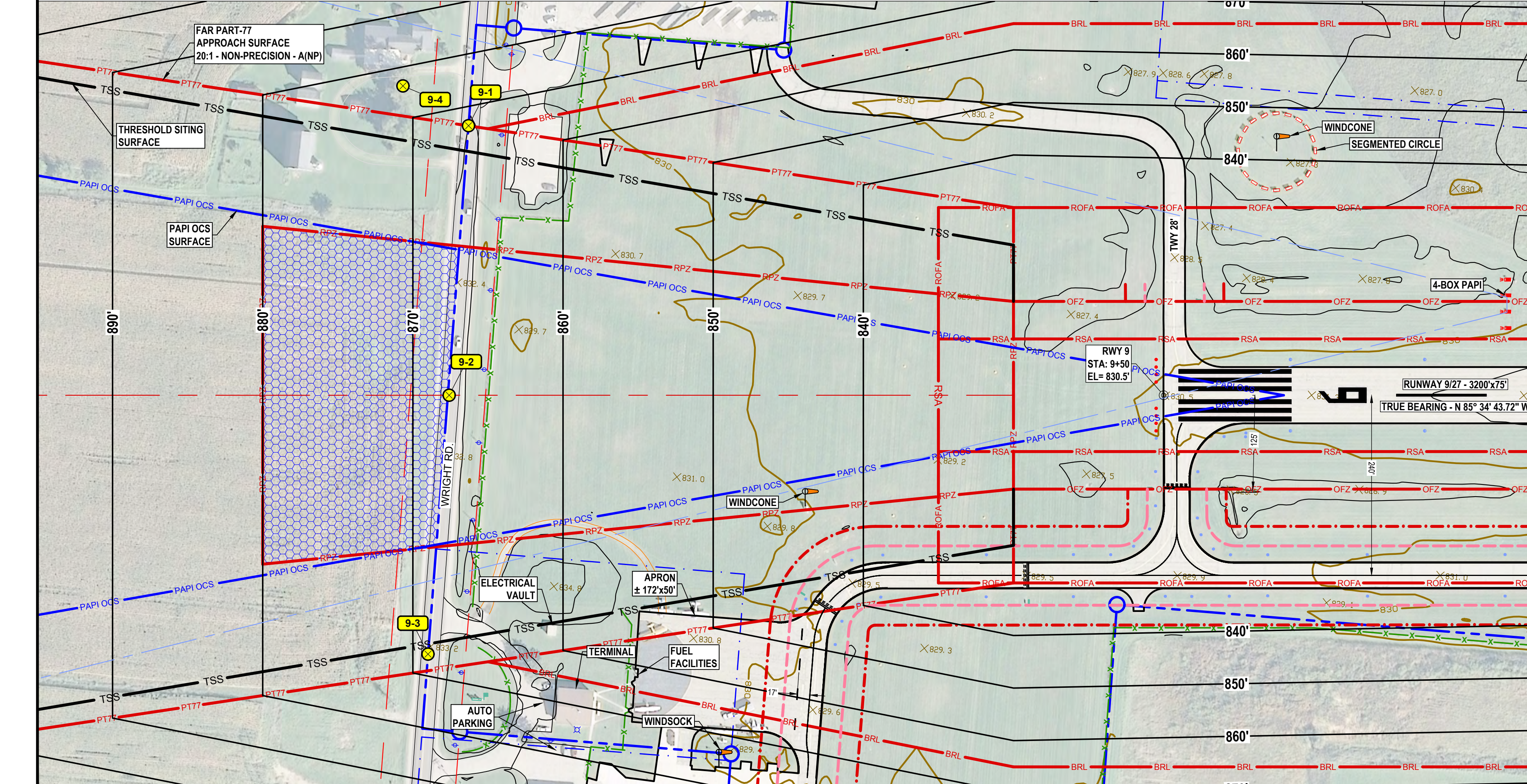

**LEGEND**

EXISTING	
	GROUND CONTOUR (2' INTERVAL)
	ROAD
	ROAD RIGHT-OF-WAY (R.O.W.)
	FENCE
	WINDSOCK
	POWER POLE, LIGHT POLE
	RUNWAY LIGHTING
	RUNWAY, TAXIWAY, PARKING
	RUNWAY MARKING
	RUNWAY CENTERLINE
	FAR PART-77 APPROACH SURFACE
	FAR PART-77 BACKSLOPES
	THRESHOLD SITING SURFACE
	PAPI OCS SURFACE
	PAPI LSCS SURFACE
	RUNWAY PROTECTION ZONE
	RUNWAY SAFETY AREA
	RUNWAY OBJECT FREE AREA
	OBSTACLE FREE ZONE/RUNWAY OBJECT FREE AREA
	OBSTACLE FREE ZONE
	BUILDING RESTRICTION LINE
	TAXIWAY SAFETY AREA
	TAXIWAY OBJECT FREE AREA
	AIRPORT PROPERTY LINE
	PROPERTY PARCEL
	SECTION LINE
	AVIGATION EASEMENT

**RUNWAY SAFETY AREAS**

ABBR.	DESCRIPTION	EXISTING
RPZ	RUNWAY PROTECTION ZONE	250' x 450' x 1000'
RSA	RUNWAY SAFETY AREA	300' x 150'
ROFA	RUNWAY OBJECT FREE AREA	300' x 500'
OFZ	OBSTACLE FREE ZONE	200' x 250'
POFZ	PRECISION OBSTACLE FREE ZONE	N/A
AS	FAR PART-77 APPROACH SURFACE	500' x 2,000' x 5,000'
	THRESHOLD SITING SURFACE CATEGORY	CAT-4
TSS	THRESHOLD SITING SURFACE DIMENSION	400' x 3800' x 10,000'
	THRESHOLD SITING SURFACE SLOPE	20:1

**NOTE:**  
1. RUNWAY SAFETY AREAS (RSA, ROFA, OFZ) RUN THE ENTIRE LENGTH OF THE RUNWAY WHILE THE DIMENSIONS SHOWN ARE FOR LENGTHS BEYOND THE RUNWAY END.

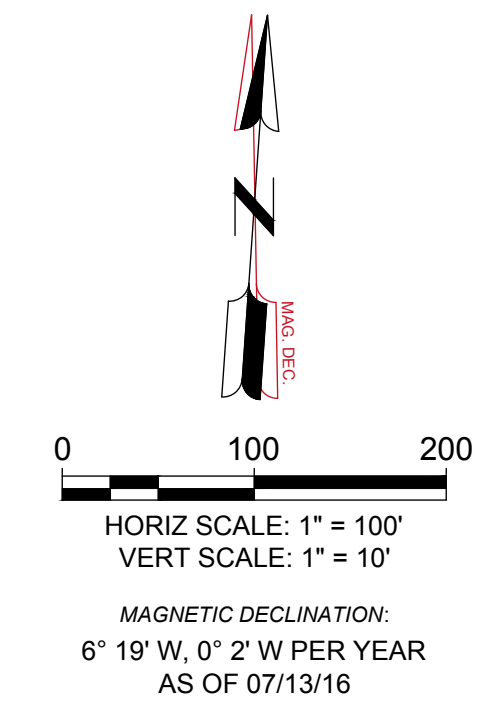

**OBSTRUCTION TABLE**

OBJECT NUMBER	OBJECT DESCRIPTION	OBJECT ELEVATION	ALLOWABLE ELEVATION		SURFACE PENETRATION		OBJECT DISPOSITION
			PART-77	TSS	PART-77	TSS	
9-1	ROAD	847'	886'	N/A	-19'	N/A	REMAIN
9-2	ROAD	847'	867'	867'	-20'	-20'	REMAIN
9-3	ROAD	848'	869'	N/A	-21'	N/A	REMAIN
9-4	TREE	896'	876'	N/A	20'	N/A	DONH

**NOTE:**  
1. THE "TOP ELEVATION" AND "ALLOWABLE ELEVATION" ARE SHOWN AT "ABOVE MEAN SEA LEVEL" (AMSL).  
2. THE PENETRATION ELEVATIONS ARE SHOWN AT ABOVE GROUND LEVEL (AGL).  
3. THE TOP ELEVATION FOR ROADS AND RAILROADS IS THE TRAVERSEWAY ELEVATION PLUS ADJUSTMENT. (23' RAILROAD, 17' INTERSTATE HWY, 15' PUBLIC ROAD, AND 10' PRIVATE ROAD)

**OBSTRUCTION TABLE LEGEND**

OBJECT NUMBER	OBJECT LABEL ON PLAN AND PROFILE VIEW
OBJECT DESCRIPTION	TYPE OF OBJECT - (EX. ROAD, TREES, BUILDINGS)
OBJECT ELEVATION	HIGHEST POINT OF OBJECT (IN AMSL)
ALLOWABLE ELEVATION	ELEVATION ALLOWED BY THE APPROACH SURFACE (EX. PART-77, TSS, OCS)
SURFACE PENETRATION	AMOUNT OF OBJECT LOCATED WITHIN APPROACH SURFACE
OBJECT DISPOSITION	THE DETERMINATION OF WHAT ACTION TO TAKE TO MITIGATE THE OBJECT

**OBJECT DISPOSITION LEGEND**

REMAIN	THE OBJECT IS LOCATED WITHIN A RUNWAY SURFACE, HOWEVER, IT DOES NOT PENETRATE THE APPROACH SURFACE, AND IN SOME CASES, THE OBJECT MAY HAVE ALREADY BEEN APPROVED TO REMAIN AT THE LOCATION. (I.E. THOSE WITH OBSTRUCTION LIGHTS)
LOWER	THE OBJECT IS A TREE WHICH NEEDS TO BE PRUNED (AS FUNDING BECOMES AVAILABLE) IN ORDER TO MAINTAIN HEIGHT CLEARANCE DUE TO MINIMAL IMPACT INTO THE FAR PART-77 APPROACH SURFACE.
REMOVAL	THE OBJECT IS CONSIDERED AN OBSTRUCTION AND SHOULD BE COMPLETELY REMOVED.
TSS	THE OBJECT IS CONSIDERED A POTENTIAL HAZARD AND BY APPLYING THE THRESHOLD SITING SURFACE THE OBJECT BECOMES A NON-HAZARD OR THE PENETRATION IS REDUCED.
DONH	IT IS RECOMMENDED THAT A REQUEST FOR A DETERMINATION OF NON-HAZARD BE FILED WITH THE FAA ASKING FOR ADDITIONAL ANALYSIS TO DETERMINE IF THE OBJECT IS A HAZARD TO AIRCRAFT NAVIGATION.

- OBSTRUCTION NOTES**
- OBJECTS IN THE TRANSITIONAL SURFACE DESIGNATED BY THE SYMBOL "T".
  - OBSTRUCTION MITIGATION IN THE TRANSITIONAL SURFACE NOT OWNED BY THE AIRPORT SHOULD BE CLEARED AS FUNDS BECOME AVAILABLE.
  - TREES DESIGNATED FOR "REMOVAL" WILL BE DETERMINED AT TIME OF CONSTRUCTION. FINAL DISPOSITION (PRUNING OR REMOVAL) WILL BE BASED UPON ACTUAL HEIGHT OF TREES AND PREFERENCE OF OWNER.
  - TRIGGERING EVENT-- THERE ISN'T A TRIGGERING EVENT.
  - OBSTRUCTION INFORMATION WAS TAKEN FROM AN FAA AC 17B COMPLIANT RUNWAY APPROACH OBSTRUCTION SURVEY PROVIDED BY QUANTUM SPATIAL, INC.

- GENERAL NOTES**
- BASE INFORMATION, INCLUDING AERIAL, PROVIDED BY QUANTUM SPATIAL (JULY 2015) AND SUPPLEMENTED WITH FIELD SURVEY DATA PROVIDED BY MEAD & HUNT, INC. WHERE NECESSARY.
  - RUNWAY COORDINATES TAKEN FROM AIRPORT 5010.
  - FENCE SURROUNDING THE AIRPORT IS COMPOSED OF A 6' CHAIN LINKED FENCE SURROUNDING THE NORTHWEST CORNER OF THE AIRPORT PROPERTY LINE, A 4' WOODEN FENCE ALONG THE WESTERN PROPERTY LINE AND AROUND THE TERMINAL AREA, AND A 5' CHAIN LINK GATE ALONG THE SOUTHERN PROPERTY LINE LEADING INTO THE AIRPORT JUST EAST OF THE MICHIGAN NATIONAL GUARD AREA.
  - APRONS MAY VARY IN SHAPE, THEREFORE, THE SIZE SHOWN IS CALCULATED FROM POINTS THAT MAKE UP THE LARGEST RECTANGULAR SHAPE FOR EACH AREA.
  - DISTANCE FROM TAXIWAY CENTERLINE TO AIRCRAFT PARKING IS THE SAME AS THE TAXIWAY OBJECT FREE AREA DIMENSION UNLESS OTHERWISE SHOWN.
  - THERE ARE NO SPECIAL USE AREAS (I.E., AGRICULTURAL SPRAYING, DEICING/CONTAINMENT).
  - THE NORTH MAGNETIC DECLINATION WAS CALCULATED ON 07/13/16, USING THE MOST RECENT WORLD MAGNETIC MODEL (WMM), EPOCH YEARS 2014-2019, FOUND AT WWW.NGDC.NOAA.GOV/GEO/MAG-WEBS/#DECLINATION. DECLINATION RESULTS ARE ACCURATE WITHIN A VARIANCE OF ± 0' 23" W.
  - THE LOCATION OF THE "BRL" IS DEPENDENT UPON THE SELECTED ALLOWABLE STRUCTURE HEIGHT WHICH IS 35 FEET.
  - THE TERRAIN PROFILE ALONG THE EXTENDED RUNWAY CENTERLINE IS REPRESENTED AS A COMPOSITE PROFILE, WHICH IS BASED ON THE HIGHEST TERRAIN ACROSS THE WIDTH AND LENGTH OF THE APPROACH SURFACE, AND NOT ALONG THE RUNWAY CENTERLINE ONLY.
  - RUNWAY 9/27 WAS REHABILITATED IN 2019 AND THE GROUND CONTOUR LINES SHOWN ALONG THE RUNWAY ARE FROM BEFORE THAT PROJECT. CONTOUR LINES MAY NOT REFLECT ACTUAL GROUND CONDITIONS

X:\071660\21008\111\CH\041918\_01\_AEP\_OF\_EXP\APP.DWG  
10/2023 4:42:51 PM

REVISIONS

1	DATE: 8/20	BY: MJF
RUNWAY REHABILITATION BA-26-0103-1913		
2	DATE: 9/22	BY: AEF
PARALLEL TAXIWAY & APRON REHABILITATION (F-26-0103-2421)		
3	DATE: 1/23	BY: AEF
REMOVE EXISTING & FUTURE CROSSWIND RUNWAY 18/36		

M&H PROJ. NO: 071660-150857.01  
FEDERAL NO: B-26-0103-1913  
STATE ID: 19-06  
DATE: 6/16  
DESIGNED BY: AEF  
DRAWN BY: GAM  
CHECKED BY: SADW

DO NOT SCALE DRAWINGS

SHEET CONTENTS

EXISTING RWY 27  
INNER APPROACH  
SURFACE PLAN

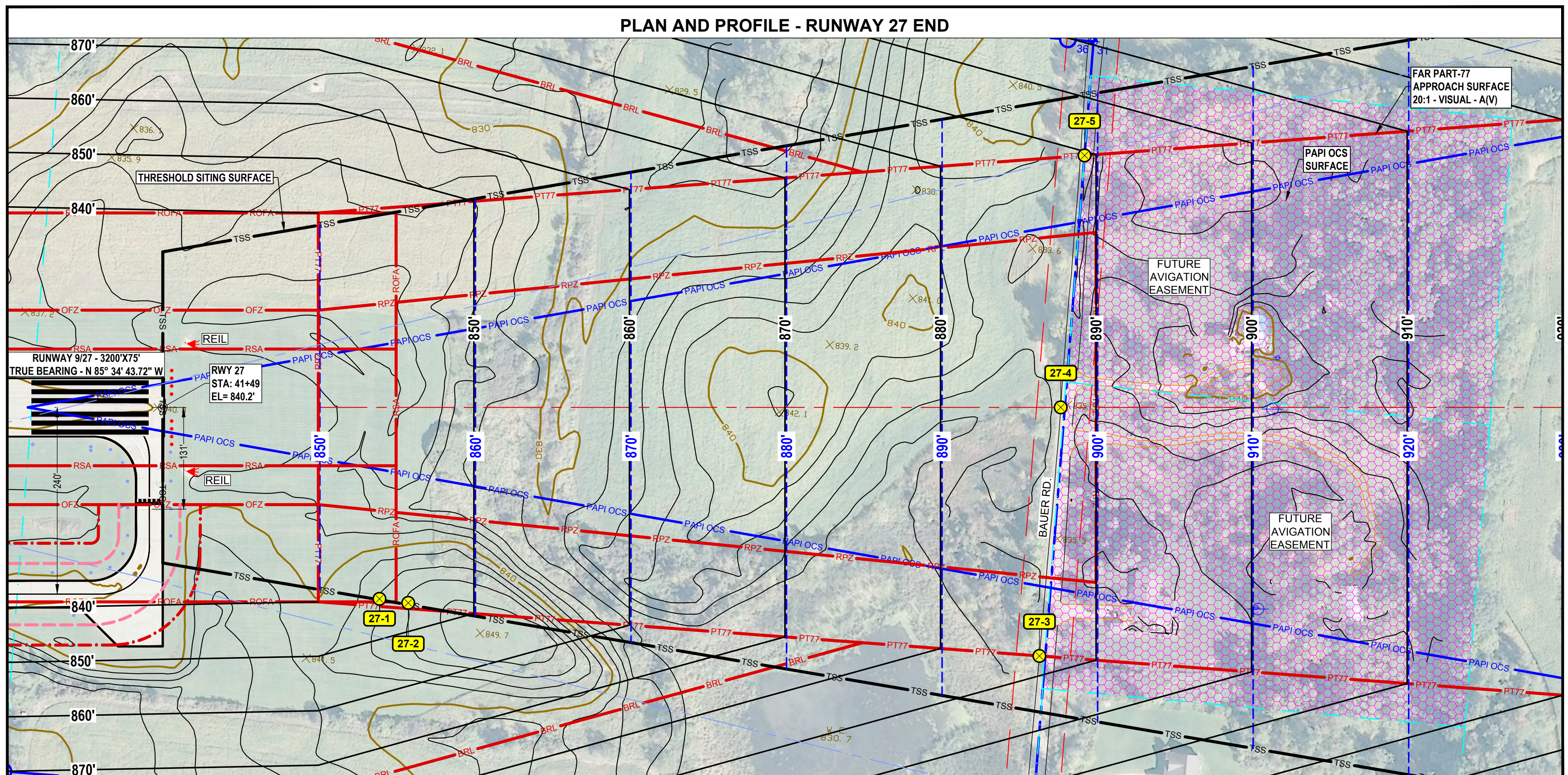

**LEGEND**

**EXISTING**

- GROUND CONTOUR (2' INTERVAL)
- ROAD
- ROAD RIGHT-OF-WAY (R.O.W.)
- POWER POLE, LIGHT POLE
- RUNWAY LIGHTING
- RUNWAY, TAXIWAY, PARKING
- RUNWAY MARKING
- RUNWAY CENTERLINE
- FAR PART-77 APPROACH SURFACE
- FAR PART-77 BACKSLOPES
- THRESHOLD SITING SURFACE
- PAPI OCS SURFACE
- PAPI LSCS SURFACE
- RUNWAY PROTECTION ZONE
- RUNWAY SAFETY AREA
- ROFA
- OFZ
- BUILDING RESTRICTION LINE
- TAXIWAY SAFETY AREA
- TAXIWAY OBJECT FREE AREA
- AIRPORT PROPERTY LINE
- PROPERTY PARCEL
- SECTION LINE
- FUTURE AVIGATION EASEMENT
- SECTION CORNER

**RUNWAY SAFETY AREAS**

ABBR.	DESCRIPTION	EXISTING
RPZ	RUNWAY PROTECTION ZONE	250' x 450' x 1000'
RSA	RUNWAY SAFETY AREA	300' x 150'
ROFA	RUNWAY OBJECT FREE AREA	300' x 500'
OFZ	OBSTACLE FREE ZONE	200' x 250'
POFZ	PRECISION OBSTACLE FREE ZONE	N/A
AS	FAR PART-77 APPROACH SURFACE	500' x 1250' x 5000' 2
TSS	THRESHOLD SITING SURFACE CATEGORY	CAT-4
	THRESHOLD SITING SURFACE DIMENSION	400' x 3800' x 10,000' 3
	THRESHOLD SITING SURFACE SLOPE	20:1

**NOTE:**

- RUNWAY SAFETY AREAS (RSA, ROFA, OFZ) RUN THE ENTIRE LENGTH OF THE RUNWAY WHILE THE DIMENSIONS SHOWN ARE FOR LENGTHS BEYOND THE RUNWAY END.
- THE EXISTING RWY 27 FAR PART-77 APPROACH SURFACE INNER WIDTH DIMENSION CORRESPONDS TO THE WIDTH OF THE PRIMARY SURFACE WHICH IS REGULATED BY THE RWY 9 FAR PART-77 APPROACH SURFACE.
- THE 200' OFFSET OF THE THRESHOLD SITING SURFACE TO BE AVOIDED DUE TO THE USE OF A VISUAL GUIDANCE SLOPE INDICATOR (VGS) AS PER NOTE 1 TO TABLE 3-2 OF THE FAA AC 150/5300-13A.

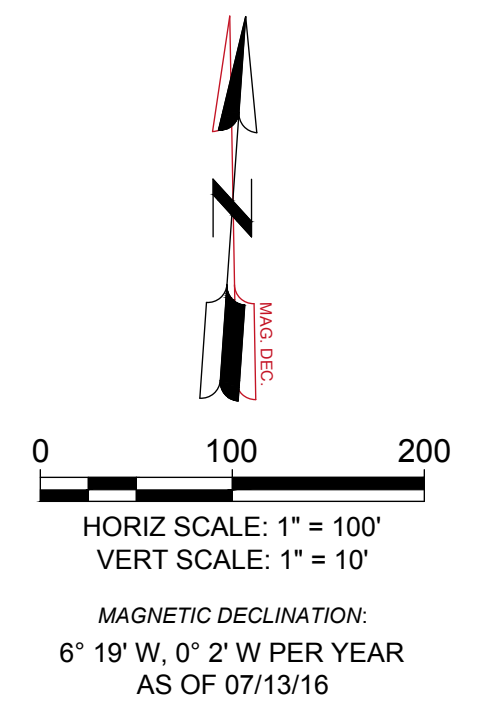

**OBSTRUCTION TABLE**

OBJECT NUMBER	OBJECT DESCRIPTION	OBJECT ELEVATION	ALLOWABLE ELEVATION		SURFACE PENETRATION		OBJECT DISPOSITION
			PART-77	TSS	PART-77	TSS	
27-1	TERRAIN	846'	845'	853'	1'	-7'	TSS
27-2	TERRAIN	848'	847'	855'	1'	-7'	TSS
27-3	ROAD <sup>3</sup>	851'	889'	889'	-38'	-38'	REMAIN
27-4	ROAD <sup>3</sup>	850'	887'	887'	-37'	-37'	REMAIN
27-5	ROAD <sup>3</sup>	850'	886'	887'	-36'	-37'	REMAIN

**NOTE:**

- THE "TOP ELEVATION" AND "ALLOWABLE ELEVATION" ARE SHOWN AT "ABOVE MEAN SEA LEVEL" (AMSL).
- THE PENETRATION ELEVATIONS ARE SHOWN AT ABOVE GROUND LEVEL (AGL).
- THE TOP ELEVATION FOR ROADS AND RAILROADS IS THE TRAVERSEWAY ELEVATION PLUS ADJUSTMENT. (23' RAILROAD, 17' INTERSTATE HWY, 15' PUBLIC ROAD, AND 10' PRIVATE ROAD)

**OBSTRUCTION TABLE LEGEND**

OBJECT NUMBER: OBJECT LABEL ON PLAN AND PROFILE VIEW  
 OBJECT DESCRIPTION: TYPE OF OBJECT - (EX. ROAD, TREES, BUILDINGS)  
 OBJECT ELEVATION: HIGHEST POINT OF OBJECT (IN AMSL)  
 ALLOWABLE ELEVATION: ELEVATION ALLOWED BY THE APPROACH SURFACE (EX. PART-77, TSS, OCS)  
 SURFACE PENETRATION: AMOUNT OF OBJECT LOCATED WITHIN APPROACH SURFACE  
 OBJECT DISPOSITION: THE DETERMINATION OF WHAT ACTION TO TAKE TO MITIGATE THE OBJECT

**OBJECT DISPOSITION LEGEND**

REMAIN: THE OBJECT IS LOCATED WITHIN A RUNWAY SURFACE; HOWEVER, IT DOES NOT PENETRATE THE APPROACH SURFACE, AND IN SOME CASES, THE OBJECT MAY HAVE ALREADY BEEN APPROVED TO REMAIN AT THE LOCATION. (I.E. THOSE WITH OBSTRUCTION LIGHTS)  
 LOWER: THE OBJECT IS A TREE WHICH NEEDS TO BE PRUNED (AS FUNDING BECOMES AVAILABLE) IN ORDER TO MAINTAIN HEIGHT CLEARANCE DUE TO MINIMAL IMPACT INTO THE FAR PART-77 APPROACH SURFACE.  
 REMOVAL: THE OBJECT IS CONSIDERED AN OBSTRUCTION AND SHOULD BE COMPLETELY REMOVED.  
 TSS: THE OBJECT IS CONSIDERED A POTENTIAL HAZARD AND BY APPLYING THE THRESHOLD SITING SURFACE THE OBJECT BECOMES A NON-HAZARD OR THE PENETRATION IS REDUCED.  
 DONH: IT IS RECOMMENDED THAT A REQUEST FOR A DETERMINATION OF NON-HAZARD BE FILED WITH THE FAA ASKING FOR ADDITIONAL ANALYSIS TO DETERMINE IF THE OBJECT IS A HAZARD TO AIRCRAFT NAVIGATION.

- OBSTRUCTION NOTES**
- OBJECTS IN THE TRANSITIONAL SURFACE DESIGNATED BY THE SYMBOL "T".
  - OBSTRUCTION MITIGATION IN THE TRANSITIONAL SURFACE NOT OWNED BY THE AIRPORT SHOULD BE CLEARED AS FUNDS BECOME AVAILABLE.
  - TREES DESIGNATED FOR "REMOVAL" WILL BE DETERMINED AT TIME OF CONSTRUCTION. FINAL DISPOSITION (PRUNING OR REMOVAL) WILL BE BASED UPON ACTUAL HEIGHT OF TREES AND PREFERENCE OF OWNER.
  - TRIGGERING EVENT-- THERE ISN'T A TRIGGERING EVENT.
  - OBSTRUCTION INFORMATION WAS TAKEN FROM AN FAA AC 17B COMPLIANT RUNWAY APPROACH OBSTRUCTION SURVEY PROVIDED BY QUANTUM SPATIAL, INC.

- GENERAL NOTES**
- BASE INFORMATION, INCLUDING AERIAL, PROVIDED BY QUANTUM SPATIAL (JULY 2015) AND SUPPLEMENTED WITH FIELD SURVEY DATA PROVIDED BY MEAD & HUNT, INC. WHERE NECESSARY.
  - RUNWAY COORDINATES TAKEN FROM AIRPORT 5010.
  - FENCE SURROUNDING THE AIRPORT IS COMPOSED OF A 6' CHAIN LINKED FENCE SURROUNDING THE NORTHWEST CORNER OF THE AIRPORT PROPERTY LINE, A 4' WOODEN FENCE ALONG THE WESTERN PROPERTY LINE AND AROUND THE TERMINAL AREA, AND A 5' CHAIN LINK GATE ALONG THE SOUTHERN PROPERTY LINE LEADING INTO THE AIRPORT JUST EAST OF THE MICHIGAN NATIONAL GUARD AREA.
  - APRONS MAY VARY IN SHAPE, THEREFORE, THE SIZE SHOWN IS CALCULATED FROM POINTS THAT MAKE UP THE LARGEST RECTANGULAR SHAPE FOR EACH AREA.
  - DISTANCE FROM TAXIWAY CENTERLINE TO AIRCRAFT PARKING IS THE SAME AS THE TAXIWAY OBJECT FREE AREA DIMENSION UNLESS OTHERWISE SHOWN.

- THERE ARE NO SPECIAL USE AREAS (I.E., AGRICULTURAL SPRAYING, DEICING/CONTAINMENT).
- THE NORTH MAGNETIC DECLINATION WAS CALCULATED ON 07/13/16, USING THE MOST RECENT WORLD MAGNETIC MODEL (WMM), EPOCH YEARS 2014-2019, FOUND AT WWW.NGDC.NOAA.GOV/GEOMAG-WEBS/DECLINATION. DECLINATION RESULTS ARE ACCURATE WITHIN A VARIANCE OF ± 0° 23' W.
- THE LOCATION OF THE "BRL" IS DEPENDENT UPON THE SELECTED ALLOWABLE STRUCTURE HEIGHT WHICH IS 35 FEET.
- THE TERRAIN PROFILE ALONG THE EXTENDED RUNWAY CENTERLINE IS REPRESENTED AS A COMPOSITE PROFILE, WHICH IS BASED ON THE HIGHEST TERRAIN ACROSS THE WIDTH AND LENGTH OF THE APPROACH SURFACE, AND NOT ALONG THE RUNWAY CENTERLINE ONLY.
- RUNWAY 9/27 WAS REHABILITATED IN 2019 AND THE GROUND CONTOUR LINES SHOWN ALONG THE RUNWAY ARE FROM BEFORE THAT PROJECT. CONTOUR LINES MAY NOT REFLECT ACTUAL GROUND CONDITIONS.

X:\071660\2016-0103\1913\1913-0103-1913-0103-1913.dwg  
10/20/2016 4:48:17 PM

These documents shall not be used for any purpose or project for which it is not intended. Mead & Hunt shall be indemnified by the client and held harmless from all claims, damages, liabilities, losses, and expenses, including attorney's fees and costs, arising out of such misuse or reuse of the documents. In addition, unauthorized reproduction of these documents, in part or as a whole, is prohibited.

**ABRAMS MUNICIPAL AIRPORT  
AIRPORT LAYOUT PLAN**  
GRAND LEDGE, MICHIGAN

REVISIONS		
1	DATE: 8/20	BY: MJF
RUNWAY REHABILITATION BA-26-0103-1913		
2	DATE: 9/22	BY: AEF
PARALLEL TAXIWAY & APRON REHABILITATION (F-26-0103-2421)		
3	DATE: 1/23	BY: AEF
REMOVE EXISTING & FUTURE CROSSWIND RUNWAY 18/36		

MAH PROJ. NO: 071660-150857.01  
FEDERAL NO: B-26-0103-1913  
STATE ID: 19-06  
DATE: 6/16  
DESIGNED BY: AEF  
DRAWN BY: GAM  
CHECKED BY: SADW  
DO NOT SCALE DRAWINGS

SHEET CONTENTS  
**AERIAL PLAN**

SHEET NO.

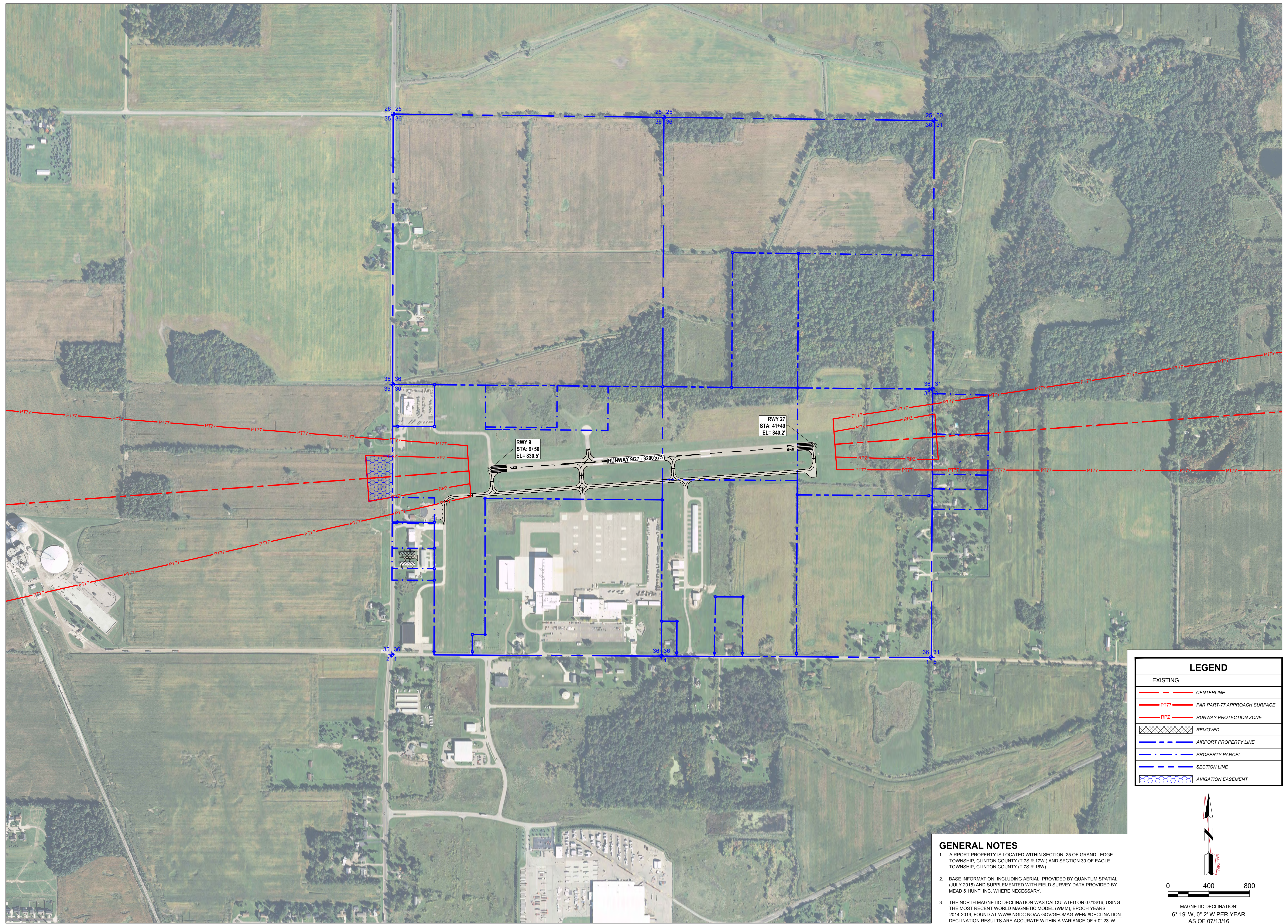

LEGEND	
	EXISTING CENTERLINE
	PT77 FAR PART-77 APPROACH SURFACE
	RPZ RUNWAY PROTECTION ZONE
	REMOVED
	AIRPORT PROPERTY LINE
	PROPERTY PARCEL
	SECTION LINE
	AVIGATION EASEMENT

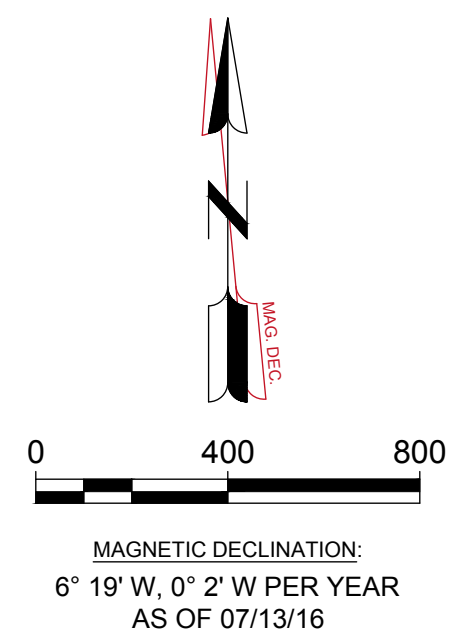

**GENERAL NOTES**

- AIRPORT PROPERTY IS LOCATED WITHIN SECTION 25 OF GRAND LEDGE TOWNSHIP, CLINTON COUNTY (T.75.R.16W.) AND SECTION 30 OF EAGLE TOWNSHIP, CLINTON COUNTY (T.75.R.16W.).
- BASE INFORMATION, INCLUDING AERIAL, PROVIDED BY QUANTUM SPATIAL (JULY 2015) AND SUPPLEMENTED WITH FIELD SURVEY DATA PROVIDED BY MEAD & HUNT, INC. WHERE NECESSARY.
- THE NORTH MAGNETIC DECLINATION WAS CALCULATED ON 07/13/16, USING THE MOST RECENT WORLD MAGNETIC MODEL (WMM), EPOCH YEARS 2014-2019, FOUND AT [WWW.NGDC.NOAA.GOV/GEOMAG-WEBSITE/DECLINATION](http://WWW.NGDC.NOAA.GOV/GEOMAG-WEBSITE/DECLINATION). DECLINATION RESULTS ARE ACCURATE WITHIN A VARIANCE OF ± 0° 23' W.

These documents shall not be used for any purpose or project for which it is not intended. Mead & Hunt shall be indemnified by the client and held harmless from all claims, damages, liabilities, losses, and expenses, including attorney's fees and costs, arising out of such use or reuse of the documents. In addition, unauthorized reproduction of these documents, in part or as a whole, is prohibited.

TITLE INTEREST IN FEE & AVIGATION EASEMENT RIGHTS									
FEDERAL PROJECT NUMBER	PARCEL NUMBER	GRANTORS	TYPE OF MEASUREMENT	LIBER & PAGE	DATE RECORDED	FEE ACREAGE	EASEMENT ACREAGE	CONTROLLING HEIGHTS (1)	NOTES
	1	J. MOWERY ET UX	WD	L.299 - P.430	9-30-59	13.67			
	2	W. ABRAMS ET UX	WD	L.308 - P.21	9-19-82	74.66			
	3	L. SANDBOURN ET UX	WD	L.336 - P.684	12-3-70	36.21			
5-26-0103-01	4	LEDGE INVESTMENTS	WD	L.368 - P.666	2-27-82	32.48			
5-26-0103-01	5	GD. LEDGE AVIATION	WD	L.375 - P.573	10-4-79	2.38			
	6	WILKINS	DE	L.368 - P.279	7-14-78	0.07			2
	7A	STATE OF MICHIGAN	QC	L.389 - P.776	3-11-82	3.34			
	7B	STATE OF MICHIGAN	QC	L.389 - P.776	3-11-82	6.59			
	7C	STATE OF MICHIGAN	QC	L.389 - P.776	3-11-82	5.27			
B-26-0103-1107	8	R. SOLTOW	WD	L.622 - P.99-101	12-27-93	49.47			
B-26-0103-1207	E9	DIXON	DT, AE	#5159071	07-19-10		2.41	870' MSL - 880' MSL	3
TOTAL FEE PROPERTY INTEREST							± 224.14 AC.		
TOTAL AVIGATION EASEMENT							± 2.41 AC.		

**PARCEL AND EASEMENT NOTES:**

- CONTROLLING HEIGHTS COLUMN LISTS THE CRITERIA USED IN DETERMINING THE GOVERNING HEIGHTS AT WHICH THE AVIGATION EASEMENT INTERESTS WERE ACQUIRED.
- THIS PARCEL IS A DRAIN EASEMENT CONTAINING A DRAINAGE SYSTEM FOR THE AIRPORT LEADING TO THE REED DRAIN.
- AS OF THIS RECORDED DEED, THE COUNTY USES DOCUMENT NUMBERS INSTEAD OF LIBER AND PAGE NUMBERS.

TYPE OF MEASUREMENT	
ABBR.	DESCRIPTION
AE	AVIGATION EASEMENT
DE	DRAINAGE EASEMENT
DT	DECLARATION OF TAKING
QC	QUIT CLAIM DEED
WD	WARRANTY DEED

RUNWAY DATA			
ABBR.	DESCRIPTION	RUNWAY 9/27	
		EXISTING	
		9	27
	END COORDINATE - LATITUDE	42° 46' 31.02" N	42° 46' 33.45" N
	END COORDINATE - LONGITUDE	084° 44' 09.46" W	084° 43' 26.68" W
EL	ELEVATION	830.5'	840.2'
STA	STATION	9+50	41+49
	TRUE BEARING	N 85° 34' 43.72" W	N 85° 34' 43.72" W
RPZ	RUNWAY PROTECTION ZONE	250' x 450' x 1000'	250' x 450' x 1000'
RSA	RUNWAY SAFETY AREA	300' x 150'	300' x 150'
ROFA	RUNWAY OBJECT FREE AREA	300' x 500'	300' x 500'

A FUTURE LAND INTERESTS				
AREA	PHASE	REASON	ACRES	
A	FUTURE	TTF	± 2.31	
B	FUTURE	TTF	± 1.80	
C	FUTURE	TTF	± 1.00	
D	FUTURE	TTF	± 6.88	
E	FUTURE	APPROACH	± 4.95	
F	FUTURE	APPROACH	± 4.92	
G	FUTURE	TTF	± 3.85	
<b>TOTAL</b>			<b>± 25.71</b>	

LEGEND		
FUTURE	EXISTING	
N/A		BUILDING
N/A		RIVER, LAKE, COUNTY DRAIN, ETC.
N/A		FENCE
N/A		LIGHT POLE, POWER POLE
N/A		ROAD
N/A		ROAD RIGHT-OF-WAY (R.O.W.)
N/A		TURF RUNWAY
N/A		RUNWAY, TAXIWAY, PARKING
N/A		RUNWAY MARKING
N/A		CENTERLINE
N/A		RUNWAY PROTECTION ZONE
N/A		RUNWAY SAFETY AREA
N/A		RUNWAY OBJECT FREE AREA
N/A		AIRPORT PROPERTY LINE
N/A		PROPERTY PARCEL
	N/A	FEE TITLE PROPERTY
	N/A	AVIGATION EASEMENT
N/A		OVERLAP IN DEEDS
N/A		UTILITY EASEMENT
	N/A	FUTURE LAND RELEASE
N/A		SECTION LINE
N/A		CONTROL POINT
N/A		MONUMENT
N/A		SECTION CORNERS

**ABRAMS MUNICIPAL AIRPORT  
AIRPORT LAYOUT PLAN**  
GRAND LEDGE, MICHIGAN

REVISIONS

1	DATE: 8/20	BY: MJF
RUNWAY REHABILITATION BA-26-0103-1913		
2	DATE: 9/22	BY: AEF
PARALLEL TAXIWAY & APRON REHABILITATION (F-26-0103-2421)		
3	DATE: 1/23	BY: AEF
REMOVE EXISTING & FUTURE CROSSWIND RUNWAY 18/36		

M&H PROJ. NO: 071660-150857.01  
FEDERAL NO: B-26-0103-1913  
STATE ID: 62-3  
DATE: 6/16  
DESIGNED BY: AEF  
DRAWN BY: GAM  
CHECKED BY: AEF  
DO NOT SCALE DRAWINGS

SHEET CONTENTS  
**PROPERTY PLAN**

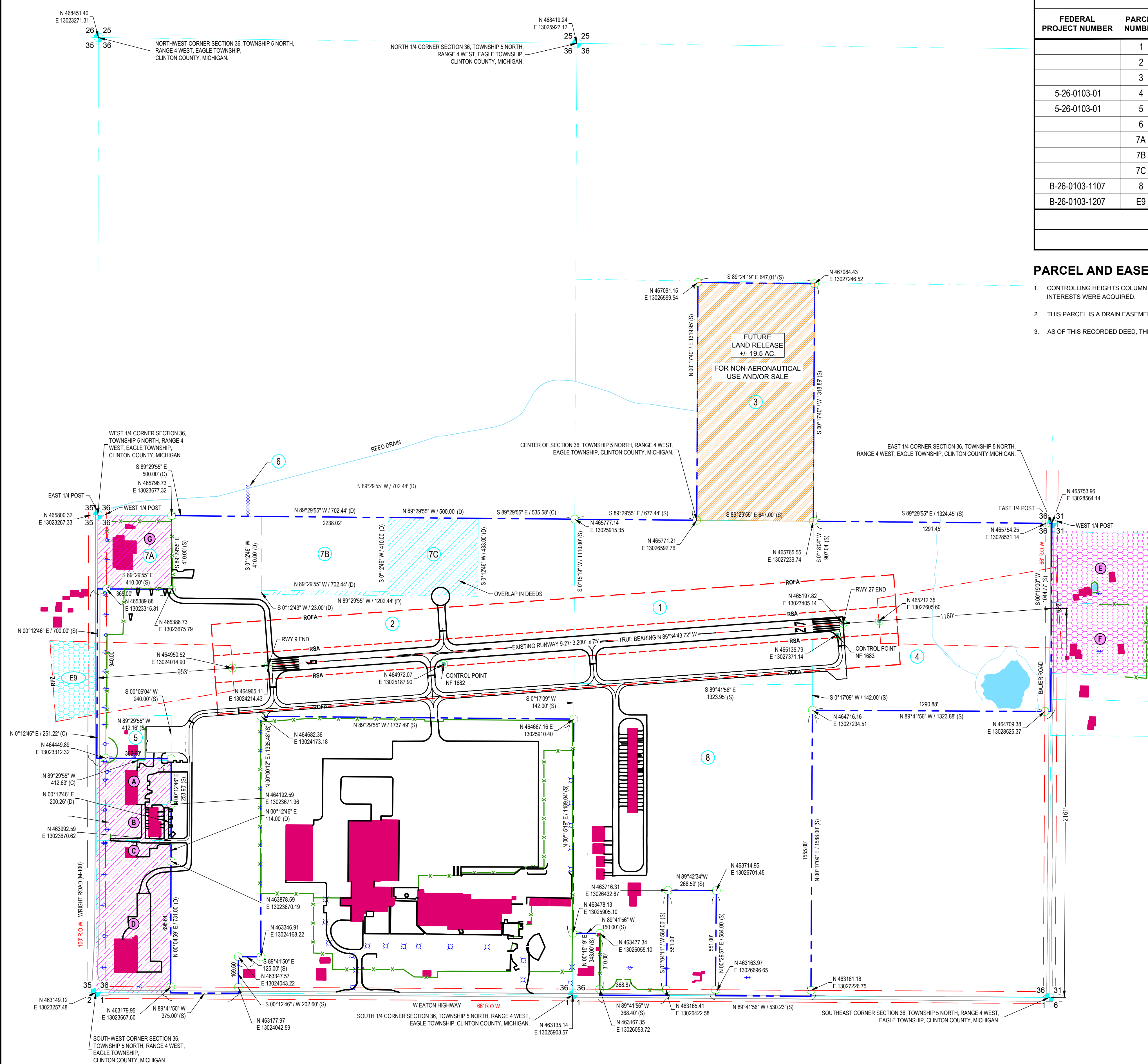

MEASUREMENT NOTATION	
ABBR.	DESCRIPTION
123 (A)	ASSUMED
123 (C)	COMPUTED
123 (D)	DEED OF PLAT
123 (S)	SURVEYED

**NOTICE**  
THE SALE OR LONG TERM LEASE (+5 YEARS) OF ANY AIRPORT PROPERTY FOR NON-AERONAUTICAL PURPOSES IS PROHIBITED WITHOUT PRIOR WRITTEN F.A.A. APPROVAL.

**AIRPORT ZONING**  
AIRPORT ZONING ORDINANCE - ENACTED UNDER ACT 23, SECTION 17 ON 1/7/1954

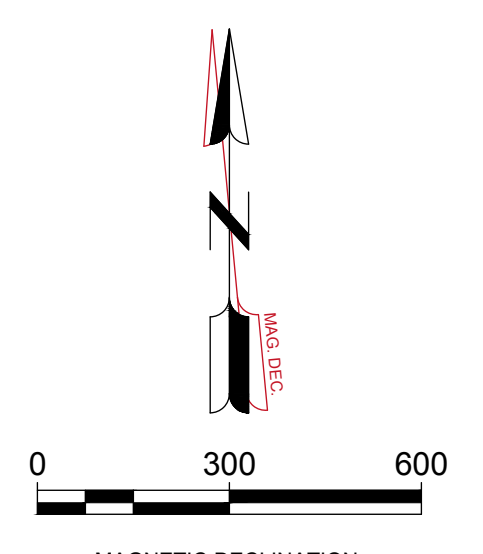

X:\071660\2022\150857\071660-150857.dwg, AEF-10 PROPERTY DWG, 11/02/2024 4:48:21 PM, 18.00, AEF-10 Property.dwg