



**Grand Ledge  
Wastewater Treatment Plant and  
Sanitary Sewer System Improvements  
Clean Water State Revolving Fund  
Draft Project Plan**

**Project No. 201424**

**DRAFT PROJECT PLAN**

**Grand Ledge  
Wastewater Treatment Plant and  
Sanitary Sewer System Improvements  
Clean Water State Revolving Fund  
Draft Project Plan**

**Prepared For:  
City of Grand Ledge, MI**

**April 1, 2022  
Project No. 201424**

***Draft Project Plan***

1.0 Background.....1

1.1 Introduction .....1

1.2 Delineation of the Study Area .....1

1.3 Environmental Setting .....1

1.3.1 Cultural Resources.....1

1.3.2 The Natural Environment .....2

1.3.2.1 Air Quality .....2

1.3.2.2 Wetlands.....3

1.3.2.3 Coastal Zones.....3

1.3.2.4 Floodplains.....3

1.3.2.5 Natural or Wild and Scenic Rivers .....3

1.3.2.6 Major Surface Waters .....3

1.3.2.7 Recreational Facilities.....4

1.3.2.8 Topography.....4

1.3.2.9 Geology.....4

1.3.2.10 Soils .....4

1.3.2.11 Agricultural Resources.....4

1.3.2.12 Fauna and Flora .....4

1.3.3 Land Use in the Study Area .....5

1.3.3.1 Existing Land Use .....5

1.3.3.2 Predicted Land Use.....5

1.4 Population .....5

1.5 Economic Characteristics.....6

1.6 Existing Facilities .....7

1.6.1 Sanitary Sewer System .....7

1.6.1.1 Overview .....7

1.6.1.2 Previous Sanitary Sewer System Improvements .....7

1.6.1.3 Sanitary Sewer Overflows .....7

1.6.2 WWTP Facility.....8

1.6.2.1 Overview .....8

1.6.2.2 Treatment Processes.....9

1.6.2.3 Electrical Power .....10

1.7 Fiscal Sustainability Plan .....10

1.7.1 Inventory of Critical Assets.....11

1.7.2 Condition and Performance Evaluation .....11

1.7.3 Water and Energy Conservation .....11

1.7.4 Plan for Maintaining, Repairing, Funding, and Replacing the Treatment Works .....11

1.8 Need for Project.....11

1.8.1 Compliance Status .....11

1.8.2 Orders .....11

1.8.3 Water Quality Problems .....11

1.8.4 Projected Needs for the Next 20 Years.....11

1.8.5 Projected Flows and Loads.....12

1.8.6 Future Environment without the Proposed Project .....13

2.0 Analysis of Alternatives .....13

2.1 Identification of Potential Alternatives .....13

- 2.1.1 Alternative 1 – No Action .....13
- 2.1.2 Alternative 2 – Optimization of Existing Facilities: Expansion of Conventional Activated Sludge .....14
- 2.1.3 Alternative 3 – Optimization of Existing Facilities: Conversion to Extended Aeration .....14
- 2.1.4 Alternative 4 – Optimization of Existing Facilities: Conversion to MBR .....15
- 2.1.5 Alternative 5 – Regional Alternative: Connection to Existing Regional WWTP .....16
- 2.1.6 Alternative 6 – Regional Alternative: Construction of New Satellite WWTP .....17
- 2.1.7 Water and Energy Efficiency .....17
- 2.2 Sanitary Sewer System Improvements .....17
- 2.3 Analysis of Principal Alternatives .....18
  - 2.3.1 Monetary Evaluation .....18
    - 2.3.1.1 Sunk Costs .....19
    - 2.3.1.2 Present Worth .....19
    - 2.3.1.3 Salvage Value .....19
    - 2.3.1.4 Escalation .....19
    - 2.3.1.5 Interest During Construction .....19
    - 2.3.1.6 Mitigation Costs .....19
    - 2.3.1.7 User Costs .....19
    - 2.3.1.8 Additional Monetary Considerations .....20
  - 2.3.2 Partitioning the Project .....20
  - 2.3.3 Environmental Evaluation .....20
  - 2.3.4 Implementability and Public Participation .....20
  - 2.3.5 Technical and Other Considerations .....20
    - 2.3.5.1 I/I Removal .....20
    - 2.3.5.2 Structural Integrity .....21
    - 2.3.5.3 Sludge Residuals .....21
    - 2.3.5.4 Industrial Pretreatment .....21
    - 2.3.5.5 Growth Capacity .....21
    - 2.3.5.6 Areas Currently Without Sewers .....21
    - 2.3.5.7 Reliability .....21
    - 2.3.5.8 Alternative Sites and Routings .....21
    - 2.3.5.9 Combined Sewer Overflows .....22
    - 2.3.5.10 Contamination at the Project Site .....22
    - 2.3.5.11 Green Project Reserve (GPR) .....22
    - 2.3.5.12 Land Requirements .....22
    - 2.3.5.13 Potential Construction Problems .....22
- 3.0 Selected Alternative .....23
  - 3.1 Relevant Design Parameters .....23
    - 3.1.1 Retention Basin .....23
    - 3.1.2 Preliminary Treatment .....23
    - 3.1.3 Primary Treatment .....24
    - 3.1.4 MBR System .....24
    - 3.1.5 Disinfection .....24
    - 3.1.6 Solids Handling .....24
    - 3.1.7 Electrical Improvements .....24
    - 3.1.8 Site Improvements .....24
    - 3.1.9 Building Modifications .....25

3.1.10 Sanitary Sewer System Improvements .....25

3.2 Project Maps .....25

3.3 Controlling Factors.....25

3.4 Special Assessment District Projects .....25

3.5 Sensitive Features .....25

3.6 Schedule for Design and Construction .....26

3.7 Cost Summary .....26

3.8 Authority to Implement the Selected Alternative.....26

3.9 User Costs .....26

3.10 Disadvantaged Community.....27

3.11 Useful Life .....27

4.0 Evaluation of Environmental Impacts .....27

4.1 Direct Impacts .....27

4.1.1 Construction Impacts .....28

4.1.2 Operational Impacts .....28

4.1.3 Social Impacts .....28

4.2 Indirect Impacts .....29

4.3 Cumulative Impacts .....29

5.0 Mitigation .....29

5.1 Short-Term Construction-Related Mitigation .....29

5.2 Mitigation of Long-Term Impacts .....29

5.2.1 Siting Decisions .....30

5.2.2 Operational Impacts .....30

5.3 Mitigation of Indirect Impacts .....30

5.3.1 Master Plan and Zoning.....30

5.3.2 Ordinances.....30

5.3.3 Staging of Construction .....30

6.0 Public Participation .....31

6.1 Public Meetings on Project Alternatives .....31

6.2 The Formal Public Hearing.....31

6.2.1 Public Hearing Advertisement.....31

6.2.2 Public Hearing Transcript .....31

6.2.3 Public Hearing Contents .....31

6.2.4 Comments Received and Answered .....31

6.3 Adoption of the Project Plan .....31

**List of Tables**

Table 1 – Air Quality Standards .....3  
 Table 2 – Federally Threatened and Endangered Species .....4  
 Table 3 – State Threatened, Endangered, Rare, and Special Concern Species .....5  
 Table 4 – Regional Municipal Population Trends .....6  
 Table 5 – Study Area Major Employers .....6  
 Table 6 – Median Annual Income Evaluation (2019) .....6  
 Table 7 – WWTP Influent Annual Average Flow Characteristics .....9  
 Table 8 – Projected Residential Equivalent Units to be Served .....12  
 Table 9 – WWTP Basis of Design – Existing and 20-Year Projected Flow and Loading .....12  
 Table 10 – Monetary Evaluation Summary .....18  
 Table 11 – Projected OM&R Costs .....19  
 Table 12 – Design and Construction Schedule .....26  
 Table 13 – Proposed Project Cost Summary .....26  
 Table 14 – Proposed Project Useful Life .....27

**List of Schematics**

Schematic 1 – Grand Ledge Sanitary System .....8

**List of Figures**

Figure 1 – Sanitary Sewer Service Area  
 Figure 2 – Wetlands and Major Surface Waters  
 Figure 3 – FEMA Floodplain  
 Figure 4 – Grand Ledge Park Map  
 Figure 5 – Topography  
 Figure 6 – Quaternary Geology  
 Figure 7 – Soils  
 Figure 8 – Prime Farmland  
 Figure 9 – Natural Features Inventory  
 Figure 10 – Existing Land use – January 2018  
 Figure 11 – Planned Land Use – January 2018  
 Figure 12 – WWTP Process Unit Capacity Schematic  
 Figure 13 – Alternative 2 Site Map  
 Figure 14 – Alternative 3 Site Map  
 Figure 15 – Alternative 4 Site Map  
 Figure 16 – Project Location Map

**List of Appendices**

Appendix 1 Cultural Resources  
 Appendix 2 Excerpt from Asset Management Plan  
 Appendix 3 Fiscal Sustainability Plan Certification Form  
 Appendix 4 EGLE Violation Notice  
 Appendix 5 NPDES Permit  
 Appendix 6 Monetary Evaluation  
 Appendix 7 Disadvantaged Community Status Determination Worksheet  
 Appendix 8 Public Hearing Advertisement  
 Appendix 9 Public Hearing Transcript, Attendee List, and Presentation (*not included in Draft Project Plan*)

Appendix 10 Resolution Adopting A Final Project Plan and Designating an Authorized Project Representative (*not included in Draft Project Plan*)

### List of Abbreviations/Acronyms

AMC	antecedent moisture conditions
AMP	Asset Management Plan
CBOD <sub>5</sub>	five-day carbonaceous biochemical oxygen demand
City	City of Grand Ledge
CSO	combined sewer overflow
EGLE	Michigan Department of Environment, Great Lakes, and Energy
FSP	Fiscal Sustainability Plan
gpm	gallons per minute
I/I	inflow and infiltration
lbs	pounds
MBR	membrane bioreactor
mgd	million gallons per day
mg/L	milligrams per liter
NAAQS	National Ambient Air Quality Standards
NFPA	National Fire Protection Association
NH <sub>3</sub> -N	ammoniacal nitrogen
NPDES	National Pollutant Discharge Elimination System
OM&R	operations, maintenance, and repair
RAS	return activated sludge
REU	residential equivalent unit
RTB	retention treatment basin
SAD	Special Assessment District
SCCUMA	Southern Clinton County Municipal Utility Authority
SESC	soil erosion and sedimentation control
SRF	State Revolving Fund
SSO	sanitary sewer overflow
Total-P	total phosphorus
TSS	total suspended solids
USEPA	U.S. Environmental Protection Agency
UV	ultraviolet
WRPS	West River Pump Station
WTP	water treatment plant
WWTP	wastewater treatment plant

## **1.0 Background**

### **1.1 Introduction**

The City of Grand Ledge (City) sanitary sewer system and wastewater treatment plant (WWTP) require improvements. The sanitary sewer system experiences high level of inflow and infiltration (I/I) and periodic sanitary sewer overflows (SSOs). The WWTP is generally able to maintain compliance with the National Pollutant Discharge Elimination System (NPDES) permit; however, it is at the hydraulic and organic loading capacity.

This Project Plan was prepared to obtain financing through the State Revolving Fund (SRF) from the Michigan Department of Environment, Great Lakes, and Energy (EGLE) for the construction of proposed improvements to the WWTP and sanitary sewer system. The WWTP requires expansion to provide capacity to the service area's residents, businesses, and industries. There is current demand for capacity from residential and commercial developments and the potential for future demand from industrial park growth. An evaluation of the wastewater treatment system capacity was conducted by Fishbeck in 2017. This study determined the WWTP was at 73% of its current 1.5 million gallon per day (mgd) hydraulic capacity and was exceeding its biological treatment capacity, and therefore has no excess capacity for future growth or development.

The sanitary sewer system has hydraulic bottlenecks and issues with I/I that limit system capacity and ability to transport sanitary wastewater to the WWTP. Sanitary sewer system improvements are required in conjunction with WWTP improvements.

### **1.2 Delineation of the Study Area**

A map of the project planning area, delineating the existing service area, is provided in Figure 1. The project planning area is comprised of regions within Eaton and Clinton Counties.

The existing service area includes the City and residential and commercial customers located in portions of Oneida and Eagle Townships. These customers are served by the existing centralized sanitary sewer system and WWTP owned and operated by the City. The sanitary sewer system is divided into five main sewer districts: West Main, North End, Sandstone, West Jefferson, and Clinton, which all connect into the River Interceptor that flows by gravity to the WWTP from Franklin Street, east of M-100, along the south side of the Grand River. The existing sewer district map is identified in Figure 1.

The WWTP is located within City owned Fitzgerald Park. The existing WWTP facilities are located at the north edge of the property along the Grand River.

### **1.3 Environmental Setting**

#### **1.3.1 Cultural Resources**

To identify sites of historical and cultural significance, the National Register of Historic Places, Michigan Historical Markers, and the list of Michigan State Historic Sites by County were reviewed. The following cultural resources have been identified within the project planning area.

The Grand Ledge Chair Company Plant, located at 101 Perry Street, Grand Ledge, MI, is included in the National Register of Historic Places. While this site is located within the planning area, proposed improvements are not anticipated to impact this historic site.

The River Ledge Historic District includes Jefferson, Scott, and Lincoln Streets between Franklin and Maple Streets. The River Ledge Historic District is included in the National Register of Historic Places. Improvements to the sanitary sewer system within the River Ledge Historic District are not anticipated to adversely impact the historic properties within the historic district.

The existing WWTP is located within City owned Fitzgerald Park, which is identified in the register of Michigan Historical Markers. The site has been used for numerous activities throughout history. The following description was provided by the Michigan History Center. Care will be taken throughout the project to minimize the impacts to Fitzgerald Park. Because the WWTP is located within Fitzgerald Park, modification to the WWTP will necessitate that there will be some impacts to Fitzgerald Park.

*Migrant Indian tribes led by the famous Chief Okemos called this area "Big Rocks." They came here in early spring to tap the sugar maples. Later, the beauty of the ledges and woods attracted the Grand Ledge Spiritualist Camp Association, which, in 1894, established a summer campground and erected the large pavilion which still stands. Thousands of spiritualists came here for summer encampments until the turn of the century. In 1919 the city of Grand Ledge bought the property and named it Riverside Park. The pavilion was used for dances, roller skating, and basketball. During World War II it housed a factory. This park's name commemorates Grand Ledge native Governor Frank D. Fitzgerald, who died in office in 1939. The pavilion was refurbished as a summer theater by the Grand Ledge Improvement Association in 1955.*

The Governor Frank D. Fitzgerald Home, located at 219 West Jefferson, Grand Ledge, MI, is identified in the register of Michigan Historical Markers. While the home is located within the planning area, proposed improvements are not expected to impact the historic site. The site was the home of Governor Frank D. Fitzgerald during his time as governor from 1935 through 1939.

Second Island is identified in the register of Michigan Historical Markers. Second Island is located in the Grand River and is not anticipated to be impacted by proposed improvements.

Blake's Opera House, located at 121 S. Bridge Street, Grand Ledge, MI, is identified in the register of Michigan Historical Markers. While Blake's Opera House is located within the planning area, proposed improvements are not expected to impact the historic site.

Because this has been deemed a non-equivalency project, correspondence with the State Historical Preservation Office and the Tribal Historic Preservation Offices was not required.

Appendix 1 contains detailed information on each of the identified historic sites.

## **1.3.2 The Natural Environment**

### **1.3.2.1 Air Quality**

The Federal Clean Air Act of 1963, as amended in 1970, 1977, and 1990, requires the U.S. Environmental Protection Agency (USEPA) to establish National Ambient Air Quality Standards (NAAQS) which define the maximum permissible concentrations for certain pollutants. In 1971, the USEPA established standards for five criteria pollutants: total suspended particulate matter (TSP), sulfur dioxide (SO<sub>2</sub>), nitrogen dioxide (NO<sub>2</sub>), carbon monoxide (CO), and photochemical oxidants. On October 5, 1978, the USEPA promulgated an additional ambient air quality standard for lead (Pb). A new air quality standard for ozone (O<sub>3</sub>) replaced the photochemical oxidant standard on February 8, 1979. In July 1987, the particulate matter standards were revised by the USEPA to place greater importance on fine particles with diameters less than 10 microns (PM<sub>10</sub>). The NAAQS Standards are provided in Table 1 for reference.

**Table 1 – Air Quality Standards**

Criteria Pollutant	Primary Criteria (Health Related)		Secondary Criteria (Welfare Related)	
	Type of Average	Standard Level Concentration	Type of Average	Standard Level Concentration
Carbon Monoxide (CO)	2 <sup>nd</sup> highest 8-hour	9 ppm (10 mg/m <sup>3</sup> )	No Secondary Standard	
	2 <sup>nd</sup> highest 1-hour	35 ppm (40 mg/m <sup>3</sup> )		
Lead (Pb)	Maximum 3-month average	0.15 µg/ m <sup>3</sup>	Same as Primary Standard	
Nitrogen Dioxide (NO <sub>2</sub> )	Annual arithmetic mean	0.053 ppm (100 µg/ m <sup>3</sup> )	Same as Primary Standard	
Ozone (O <sub>3</sub> )	4 <sup>th</sup> highest 8-hour daily maximum averaged over 3 years	0. ppm (147 µg/ m <sup>3</sup> )	Same as Primary Standard	
Particle Matter	PM <sub>10</sub> (10 micron) 24-hour	150 µg/ m <sup>3</sup>	Same as Primary Standard	
	sPM <sub>2.5</sub> (2.5 micron) annual arithmetic mean	15 µg/ m <sup>3</sup>	Same as Primary Standard	
	PM <sub>2.5</sub> 98 <sup>th</sup> percentile 24-hour averaged over 3 years	35 µg/ m <sup>3</sup>	Same as Primary Standard	
Sulfur Dioxide (SO <sub>2</sub> )	Annual arithmetic mean	0.03 ppm (80 µg/ m <sup>3</sup> )	3-hour	0.5 ppm (1300 µg/m <sup>3</sup> )
	2 <sup>nd</sup> highest 24-hour	0.14 ppm (365 µg/ m <sup>3</sup> )		

EGLE conducts air quality monitoring throughout the state. Non-attainment areas are those that have concentrations over the NAAQS standards. The study area resides in an area that is within attainment with all air quality standards. The proposed work will have no significant effect on the local air quality. Heavy equipment used for construction will temporarily increase emissions in work areas but is not expected to produce a significant or lasting effect.

**1.3.2.2 Wetlands**

Figure 2 identifies wetlands in the study area. The major water feature in the study area is the Grand River. Wetlands within the study area include freshwater emergent wetlands, freshwater forested/shrub wetlands, freshwater ponds, and riverine wetlands.

**1.3.2.3 Coastal Zones**

Grand Ledge is an inland city; there are no coastal areas within or adjacent to the City.

**1.3.2.4 Floodplains**

Figure 3 contains a Federal Emergency Management Agency (FEMA) floodplain map for the study area. Many of the 100-year floodplain areas are located adjacent to the Grand River and Sandstone Creek. Portions of the existing WWTP site are within the 100-year floodplain.

**1.3.2.5 Natural or Wild and Scenic Rivers**

Rivers within the planning area are not considered Natural or Wild and Scenic Rivers, as defined by the regulations.

**1.3.2.6 Major Surface Waters**

Major surface waters within the planning area include the Grand River and Sandstone Creek, which are identified in Figure 2.

**1.3.2.7 Recreational Facilities**

The City recently developed a *2022 – 2026 Parks and Recreation Master Plan*. This master plan identifies four existing neighborhood parks (Elaine Dible Memorial Park, Colonial Park, Fieldview Open Space, and Oakwood Greenspace), three neighborhood parks coming available in 2022 (West Washington Street Greenspace, West Main Street Greenspace, and West Front Street Greenspace), two community parks (City Hall Park and GLPS School Recreation Facility), nine regional parks (Island Park, Jaycee Park, Fitzgerald Memorial Field, Oak Park, Riverfront Park, Bridge Street Plaza, Little Fitz, Future Ball Field Complex, and Fitzgerald Park). In addition to the identified parks, the City is also home to a trail system. Recreational facilities are identified in Figure 4.

**1.3.2.8 Topography**

Elevations within the study area range from approximately 840 to 890 feet above mean sea level. Figure 5 depicts the topography in the study area.

**1.3.2.9 Geology**

The predominant geological features within the planning area that impact the choice of alternatives are the sandstone ledges along the Grand River. The sandstone ledges are an important regional geologic feature and limit the usable space near the existing WWTP site.

The study area is dominated with medium-textured glacial till with a small section of glacial outwash sand and gravel and postglacial alluvium in the southern portion of the study area. The quaternary geology of the study area is shown in Figure 6.

**1.3.2.10 Soils**

The study area includes soils classified as USA Soils Hydrogeologic Group A, Group B, Group C, Group A/D, Group B/D, and Group C/D. Figure 7 shows the soil distribution within the Study Area. While soils are not anticipated to have an adverse impact on construction activities, underlying sandstone features near the WWTP site must be considered during design.

**1.3.2.11 Agricultural Resources**

Prime farmland and farmland of local importance is identified in Figure 8. Proposed improvements are not anticipated to require the use or conversion of prime farmland or farmland of local importance.

**1.3.2.12 Fauna and Flora**

Endangered or threatened species are defined as those species that are or could become endangered or threatened and, therefore, are protected under the Endangered Species Act. The objective of the act is to preserve and restore species threatened with extinction. The federally listed endangered and threatened species are detailed in Table 2. Table 3 details the state listed endangered, threatened, rare, and special concern species for Osceola County. The Michigan Natural Features Inventory was not contacted, as this has been deemed a non-equivalency project. A natural features inventory is map is provided in Figure 9.

**Table 2 – Federally Threatened and Endangered Species**

Name	Status
Eastern Prairie Fringed Orchid	Threatened
Northern Long-Eared Bat	Threatened

**Table 3 – State Threatened, Endangered, Rare, and Special Concern Species**

Name	Status
Elktoe	Special Concern
Slippershell	Threatened
Henslow's sparrow	Endangered
Grasshopper sparrow	Special Concern
Screech owl	Endangered
Northern amber bumble bee	Special Concern
Three-seed sedge	Special Concern
Blanding's turtle	Special Concern
Common loon	Threatened
Wood turtle	Special Concern
Bald eagle	Special Concern
Vasey's rush	Threatened
Migrant loggerhead shrike	Endangered
Creek heelsplitter	Special Concern
Flutedshell	Special Concern
Black sandshell	Endangered
Pickerel frog	Special Concern
Little brown bat	Special Concern
Bigmouth shiner	Special Concern
Osprey	Special Concern
Round pigtoe	Special Concern
Eastern massasauga	Special Concern
Dickcissel	Special Concern
Butler's garter snake	Special Concern

### **1.3.3 Land Use in the Study Area**

#### **1.3.3.1 Existing Land Use**

Existing land uses within the study area include single family residential, 2-family residential, multiple family residential, mobile home community, central business district, commercial/highway services, office, industrial, churches/schools/public facilities, city and county parks, agricultural, and vacant land. Figure 10 shows the existing land use within the study area as of January 2018.

#### **1.3.3.2 Predicted Land Use**

The predicted land use is shown in Figure 11. Development within the study area includes additional residential development, multi-family residential development, and further expansion of the industrial areas.

## **1.4 Population**

A population review was conducted for the City and the townships that are served by the sanitary sewer system, with the resulting data provided in Table 4. Census data was obtained for the City as well as Oneida and Eagle Townships for 2000 and 2010. According to the City's 2018 Master Plan, the Tri-County Regional Planning Commission projected a 7.8% population increase between 2010 and 2020. However, according to U.S. Census Bureau data, only a 1.4% increase was seen from 2010 to 2019 (i.e., 0.16% annual growth) for the City. With a lack of data available at this time, populations for Oneida and Eagle Townships were estimated for 2019 and 2022 based on the actual 0.16% annual growth seen for the City. The previous Tri-County Regional Planning

Commission projected 7.8% rate of growth per 10 years was then applied for future projections for 2032 and 2042.

**Table 4 – Regional Municipal Population Trends**

Year	City of Grand Ledge	Oneida Township	Eagle Township	Total
2000	7,813*	3,703*	2,332*	13,848
2010	7,786*	3,861**	2,548**	14,195
2020	7,896*	3,914*	2,713*	14,253
2022 projection	7,921	3,928	2,722	14,571
2027 projection	8,230	4,081	2,828	15,139
2032 projection	8,551	4,240	2,934	15,725
2042 projection	9,217	4,571	3,162	16,950

\*U.S. Census Bureau

\*\*Tri-County Regional Planning Commission

The total municipal populations do not represent the projected planning area or the existing service area, as some areas of the population are served by other sanitary means. In general, population trends and projections are valuable indicators of overall regional growth. The current population served by the existing WWTP is estimated to be 8,855. The 20-year projected population served by the proposed project is estimated to be 10,305.

## 1.5 Economic Characteristics

Table 5 lists the major employers within the study area as well as the number of employees at each location and the product developed/service rendered, as provided by the City.

**Table 5 – Study Area Major Employers**

Employer	Product / Service	Number of Employees
Grand Ledge Public Schools	Education	559
Lowe's	Supply chain/shipping	550
E.T. Mackenzie	Construction/Demolition	430
Meijer Inc.	Retail/Grocery	320
E-T-M Corporation	Fiberglass Molding	130
City of Grand Ledge	Government	105
Robert Sinto Corporation	Automatic Pouring Systems	100
American Bottling Company	Automation Systems and Equipment Manufacturing	50
Independence Village	Housing	48
McDonalds	Restaurant	45

As reported in the 2019 American Community Survey of Median Annual Household Income, the median household income metrics in Grand Ledge, Eaton County, and the State of Michigan were as follows:

**Table 6 – Median Annual Income Evaluation (2019)**

Metric of Evaluation	Grand Ledge Median Annual Income	Eaton County Median Annual Income	State of Michigan Median Annual Income
Household	\$61,095	\$59,584	\$57,144
Families	\$99,686	\$75,703	\$72,600
Nonfamily households	\$45,968	\$35,755	\$33,711
Percentage of all families below poverty	8%	9%	10%

Economic trends in the planning period are not anticipated to affect the need for wastewater facilities. The City will continue to encourage investment into the community and seek ways to provide employment opportunities. Further development of the existing industrial park may help provide economic opportunities within the planning area.

## **1.6 Existing Facilities**

### **1.6.1 Sanitary Sewer System**

#### **1.6.1.1 Overview**

The collection system was originally a combined sewer system, but the City completed construction of a sewer separation project in 1991. The current sanitary sewer system is comprised of seven pump stations, over 40 miles of gravity sewer, over two miles of force main, and includes three river crossings.

#### **1.6.1.2 Previous Sanitary Sewer System Improvements**

Prior to improvements completed between 2009 and 2012, the City entered into an administrative consent order because of overflows from a manhole, MH-94, on the interceptor between the West River Pump Station (WRPS) and the WWTP and from the WRPS. There were two master planned improvements to address the flow issues. The first planned improvement was to remove the overflow at MH-94 and raise the overflow from the interceptor to WRPS which would allow the interceptor to surcharge and send more flow to the WWTP. The second planned improvement was to reroute the WRPS with a new force main directly to the WWTP. The City applied for and received an S2 grant to do flow monitoring and modeling. The flow monitoring showed that there was a significantly higher response when the antecedent moisture conditions (AMC) were high than in the summer. Also, the system appeared to have a significant response from sump pumps and footing drains. Due to the high cost of building the improvements necessary for the footing drains, it was decided to design for the summer hydrology and the City would pursue footing drain disconnections. Therefore, included in the previous sanitary sewer system improvements were.

1. Plug the overflow at MH-94
2. Construct a retention treatment basin (RTB) at the WWTP with the largest size that would fit on the current footprint
3. Raise the overflow at MH-S2
4. Increase the capacity of the WRPS to 950 gallons per minute (gpm).

Following the improvements, the interceptor experienced more surcharging than anticipated, some of which led to SSOs. The City removed a bulkhead they had at an old SSO point at MH-S4 at Russel Street to protect that area of the system. They had the interceptor cleaned and found substantial amount of sediment and solids between MH-94 and the WWTP.

#### **1.6.1.3 Sanitary Sewer Overflows**

Since completing sanitary sewer system improvements, the system has operated better and has only seen issues during high AMC events. Peak wet weather events can result in SSOs from two structures in the sanitary sewer system. Outfall 004 is located at the WRPS which serves the North End District. The Russel Street overflow is located at Manhole 211 (Outfall 005) on the River Interceptor, where the West Jefferson District discharges to the River Interceptor. Both overflows discharge to the Grand River. Below is a schematic of the system.

Schematic 1 – Grand Ledge Sanitary System

p:\cwsrf\mfg\11

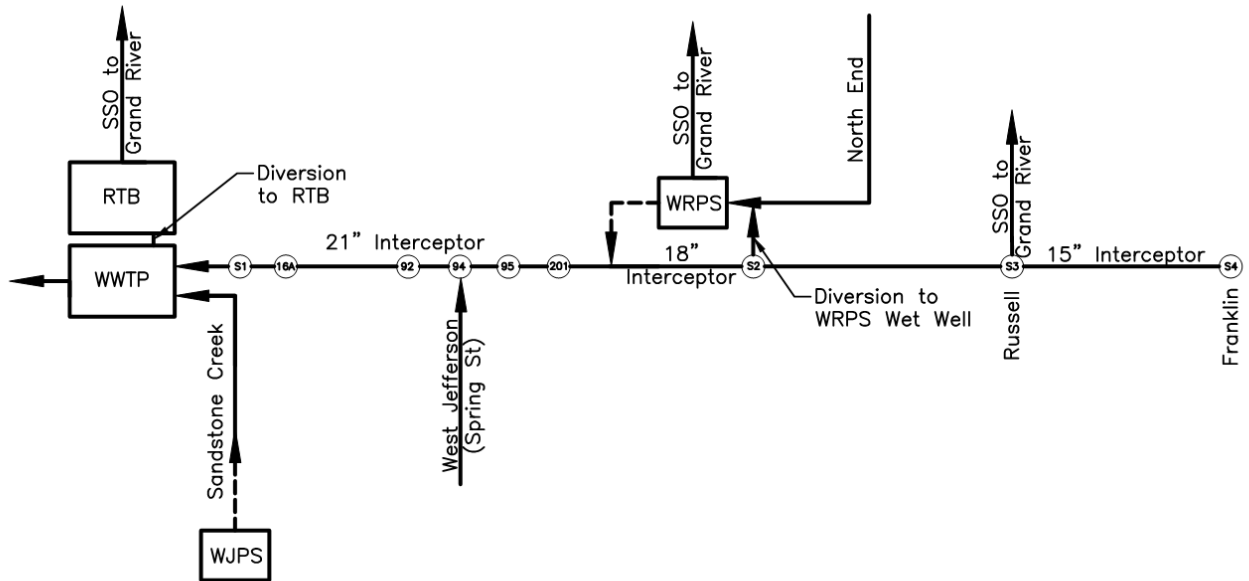

**GRAND LEDGE SYSTEM SCHEMATIC**  
NO SCALE

**1.6.2 WWTP Facility**

**1.6.2.1 Overview**

The original WWTP was constructed in the late 1930s and provided primary settling treatment and disinfection, with digesters for biosolids treatment. A major upgrade in the mid-1970s added preliminary treatment with a grinder and grit removal, installed new primary treatment tanks, and added the secondary treatment process. Essentially, everything from the original facility was removed, abandoned, or filled in at this time or since.

Two biosolids storage tanks were installed in the mid-1980s. A third biosolids storage tank was installed in the mid-1990s; a maintenance upgrade to the aeration system diffusers occurred around the same time. The most recent upgrade, in the early 2010s, included an influent diversion structure and retention tank, an upgrade to the headworks with a mechanical bar screen and Parshall flume, and expansion of the chlorine contact tank. Throughout the late 2010s, maintenance upgrades of other equipment have occurred.

The majority of the WWTP process equipment is from 1975 and largely approaching the end of its useful life. The headworks mechanical bar screen, retention treatment tank system, and intermediate lift station pumps were installed in 2010 and have remaining life suitable for continued use. The remaining process units and associated equipment are beyond their useful life, and many are at capacity. A schematic of the process unit capacities is provided in Figure 12.

Table 7 presents the WWTP influent flow characteristics from 2017 through 2020. Influent flow is metered at the Parshall flume following screening, and includes flow returned from the retention tank. Flow diversion to the retention tank is metered separately.

**Table 7 – WWTP Influent Annual Average Flow Characteristics**

Year	Flow	CBOD <sub>5</sub>		TSS		Total-P	
	mgd	mg/L	lbs/day	mg/L	lbs/day	mg/L	lbs/day
2017	1.11	297	2,489	278	2,344	5.03	42.24
2018	0.99	316	2,439	318	2,445	4.95	38.53
2019	1.11	275	2,507	234	2,048	4.37	37.49
2020	1.07	233	1,891	252	2,133	4.71	37.79
4-Year Average	1.06	291	2,395	275	2,258	4.86	39.47

CBOD<sub>5</sub> five-day carbonaceous biochemical oxygen demand

lbs pounds

mg/L milligrams per liter

Total-P total phosphorus

TSS total suspended solids

**1.6.2.2 Treatment Processes**

Wastewater is transported to the WWTP from the east through a 21-inch interceptor sewer and a 12-inch sewer, both of which transition to 24-inch pipes before entering a flow diversion structure. Under normal flow conditions, influent wastewater passes through the structure to preliminary treatment. Influent flow above 4 mgd is diverted at the flow diversion structure to the influent retention tank, which is divided into three basins. When high flow has receded, wastewater in the influent retention tank is pumped out and returned to preliminary treatment and through the WWTP. In an emergency high-flow situation where the influent retention tank fills to capacity, wastewater overflows to the plant outfall and discharges to the river. A tablet chlorinator provides chlorination of wastewater in the influent retention tank in the event of a potential overflow. The influent retention treatment tank system and tablet chlorinator were installed in 2010 and are in good condition.

Preliminary treatment includes a dual channel with a mechanical bar screen equipped with a washing screw compactor and a backup channel grinder. The mechanical bar screen and compactor were installed in the 2010 upgrade. The channel grinder is beyond its useful life and could potentially be upgraded to an additional mechanical bar screen.

Screened flow passes through a Parshall flume for influent flow metering and then through an aerated grit chamber. The grit chamber was originally installed with a mechanical screw type grit washer, which was ineffective and removed from service. In lieu, plant staff periodically employ a Vactor truck to remove collected grit and other materials from the bottom hopper of the grit chamber. Vactored material is placed in an onsite drying bed for dewatering prior to landfill disposal. Vactoring is rarely required as the grit chamber is over-aerated. Grit material remains in suspension and does not settle out. Overall, the grit collection system does not meet current treatment expectations for grit removal, washing, and dewatering.

Following the grit chamber, wastewater flows by gravity through a channel and a 20-inch pipe to an intermediate lift station wet well. Three submersible pumps with variable frequency drives are used to raise the wastewater flow to primary and secondary treatment. The pumps have been in service for approximately 10 years and are in good condition.

Wastewater from the intermediate lift station flows to the primary clarifiers. Ferric chloride and polymer are added at the primary tanks to promote the removal of phosphorus and solids, respectively. There are two rectangular primary treatment tanks with chain and flight internal mechanisms with spiral screw cross collectors. The flight mechanisms were replaced in the mid-2000s; independent drive motors were installed in 2020. The tanks are generally well maintained and may require minor equipment upgrades to assure reliability. There are two rotary lobe sludge pumps that serve the primary clarifiers.

Primary effluent flows directly into two aeration tanks equipped with fine bubble diffusers. Due to inoperable slide gates, the aeration tanks currently operate only in parallel. The diffusers were replaced approximately 13 years ago as part of plant maintenance. Process air is provided by three centrifugal aeration blowers that are controlled and throttled manually. The blowers were replaced in the late 1990s, and subsequently rebuilt one at a time between 2008 and 2014.

Mixed liquor from the aeration tanks is split and distributed to two circular final clarifiers. The final clarifiers have an 11-foot sidewall depth and do not meet current design standards. The clarifier mechanisms are original to 1975. One clarifier drive failed and had to be replaced unexpectedly in 2018. Plant staff proactively replaced the other clarifier drive the following year.

From the final clarifiers, settled sludge is pumped and returned to the aeration tanks, or wasted to the primary clarifiers, by three return activated sludge (RAS) pumps. The three RAS pumps include one original to 1975, and two new dry-pit submersible-type pumps.

Effluent from the final clarifiers combines in a chamber and flows over a rectangular weir for final effluent metering; however, effluent metering is not considered reliable. Following the weir, effluent is disinfected using chlorine gas, passing through one of three chambers of the chlorine contact tank. Chlorine gas is automatically flow-proportioned. The chlorine contact tank was expanded to a third channel in 2010, with the existing gas chlorination system relocated. The gas chlorination system equipment has been recently updated and is currently working well.

Effluent from the chlorine contact tank is mixed with sodium bisulfite to reduce residual chlorine to meet NPDES permit requirements. Final effluent is discharged to the Grand River through the 24-inch outfall pipe.

Primary sludge, waste activated sludge, and scum are pumped and injected with lime slurry prior to transfer to the three underground sludge storage tanks. The tanks are a precast concrete type. Two tanks were installed in the mid-1980s that are 250,000 gallons each, and a third tank was installed in the mid-1990s with 200,000-gallon nominal capacity. The sludge storage tanks are located on the WWTP property but are remote from the central facility. Lime slurry is metered and fed into the sludge pump discharge piping. In storage, the limed solids settle and thicken. Liquid supernatant is periodically decanted off the storage tanks and returned by gravity to the primary clarifiers. Settled solids from the storage tanks are trucked and hauled for land application. The primary sludge pumps are in fair condition. The RAS pumps are in new condition. The majority of the lime system equipment is original to 1975, converted for sludge stabilization in the early 1980s. The lime feed system is at the end of its useful life and poses operational concerns. The sludge storage tanks may need further evaluation to determine their condition and to identify any need for concrete or joint rehabilitation.

### **1.6.2.3 Electrical Power**

The plant is serviced by two primary circuits: the Academy Circuit and the Business Circuit. Both circuits enter from the south side of the property and terminate at a transfer switch located west of the Blower Building. An electrical service grounding system was installed during the 2010 upgrades to the Headworks Building, Blower Building, and the intermediate lift station. A 500-kilowatt, diesel engine powered, electric generator was installed in 2010, providing backup power to most of the plant. The generator is exercised weekly to maintain reliability.

## **1.7 Fiscal Sustainability Plan**

A fiscal sustainability plan (FSP) per SRF requirements state that treatment works proposed for repair, replacement, and expansion must develop an FSP that includes an inventory of critical assets, evaluation of condition and performance of the inventoried assets, certification of water and energy conservation efforts, and a plan for operations and maintenance and funding.

The recently completed Asset Management Plan (AMP) includes many of the same components and meets the FSP requirements for SRF funding. Excerpts from the AMP which are pertinent to the SRF FSP are provided in Appendix 2. The full AMP report is available for review by request.

### **1.7.1 Inventory of Critical Assets**

An inventory of all WWTP and lift station assets was completed as a part of the AMP and is provided in Appendix 2. This list consists of 56 WWTP assets and 50 lift station assets. In general, the existing assets have a low or medium probability of failure and a low or medium consequence of failure.

### **1.7.2 Condition and Performance Evaluation**

A condition assessment and performance evaluation for the WWTP and lift stations were completed as a part of the AMP and are provided in Appendix 2.

### **1.7.3 Water and Energy Conservation**

Water and energy conservation efforts will be implemented where fiscally and operationally practical throughout the proposed project. A certification that the City has evaluated and will strive to implement water and energy conservation efforts as a part of the proposed project plan will be submitted with the Part III Application. A blank certification form is included as Appendix 3.

### **1.7.4 Plan for Maintaining, Repairing, Funding, and Replacing the Treatment Works**

Replacement costs for WWTP and lift station assets were identified as a part of the AMP. A summary of these costs can be found in Appendix 1. The City's AMP is designed to allow for maintenance, repairing, funding, and replacement planning. A formal plan will be submitted with the Part III application.

## **1.8 Need for Project**

### **1.8.1 Compliance Status**

The WWTP has generally maintained compliance with its NPDES permit over the past 5 years with violations limited to unpermitted discharges (two instances) and clerical delinquencies (3 instances). The City received a Violation Notice on March 11, 2021, which outlined SSOs that EGLE determined to be violations of the City's existing NPDES permit. The Violation Notice is included in Appendix 4. A copy of the current NPDES permit is included in Appendix 5.

### **1.8.2 Orders**

There are currently no orders, federal or state enforcement orders, or administrative consent orders that impact the WWTP. EGLE has indicated that the Violation Notice may be escalated to a consent order.

### **1.8.3 Water Quality Problems**

Discharges from the sanitary sewer system and from the existing RTB present a water quality problem. If the WWTP were to attempt to process all water that is currently being discharged from the sanitary sewer system or from the RTB, further treatment problems, including degradation of the biological treatment process due to a loss of nitrifying bacteria, could exacerbate water quality problems currently associated with the SSOs.

### **1.8.4 Projected Needs for the Next 20 Years**

The WWTP capacity is recognized as the limiting factor to regional development in the area. The City has been unable to accept new industrial business interested in building in the area due to a lack of sanitary service capacity.

City staff provided guidance and input on expected growth and development to determine the specific areas with the largest growth potential in and around the City. These areas reflect available land such as undeveloped parcels in the industrial park and recent interest expressed to the City for residential, commercial, and industrial development. Projected growth can be grouped into three general areas: 1) South/East, 2) West, and 3) North.

Available land area was converted to residential equivalent units (REUs) based on typical development patterns in the area and commercial REUs per acre. Table 8 presents the projected REUs by region, along with existing REUs currently served, and the resulting total REUs to be served in the future. This does not include projected industrial demand, which was determined separately.

**Table 8 – Projected Residential Equivalent Units to be Served**

Region	REUs
1 – South/East	2,400
2 – West	2,000
3 – North	700
<i>Subtotal – New Regions</i>	<i>5,100</i>
Existing Service*	3,300
<b>Total To Be Served</b>	<b>8,400</b>

\* From 2020 City billing information

**1.8.5 Projected Flows and Loads**

Total projected flow and loading is summarized in Table 9. Utilizing the population growth projection and REU development projections, average flows were projected for future residential and commercial demand based on 250 gallons per day per REU. This flow rate for new developments is consistent with observed flows within the service area. Typical domestic wastewater strength values have been used to project the additional residential and commercial loading.

The WWTP currently experiences peak loads during wet weather events due to flushing of the sewers. For simplicity, the industrial and Water Treatment Plant (WTP) flows are assumed to be equalized, with no significant peaking factor.

In addition to these base flows with diurnal peaking factors, peak wet weather flows were considered: specifically, excess flows diverted to the retention tank or overflows in the sanitary sewer system. As noted previously, overflows can occur from three locations: the retention tank at the WWTP outfall, at the WRPS, and the Russel Street location (Manhole 211). Based on recent records for overflows from these three locations, the typical instantaneous SSO rate is estimated at approximately 10 mgd. As a simple conservative estimate, it was assumed that any future expansion of the WWTP should accommodate these current overflow volumes.

Total peak flows also account for the City’s WTP expansion and the potential backwash reject water. With anticipated equalization of the reject water, there would be no significant peak; therefore, the same WTP average values were used here.

**Table 9 – WWTP Basis of Design – Existing and 20-Year Projected Flow and Loading**

Parameter	Flow (mgd)	CBOD <sub>5</sub> (lbs/day)	TSS (lbs/day)	NH <sub>3</sub> -N* (lbs/day)	Total-P (lbs/day)
Existing Design Average	1.5	2,250	2,250	n/a	150
Future Design Average	3.9	6,449	7,332	864	145
Future Design Peak	14.3	9,930	12,938	1,333	209

\*ammoniacal nitrogen (NH<sub>3</sub> N)

### **1.8.6 Future Environment without the Proposed Project**

Multiple sanitary sewer system pump stations and major WWTP process equipment are approaching or beyond their expected useful life.

Current WWTP equipment that is original to 1975 includes:

- Grit chamber
- Primary clarifiers
- Aeration tanks
- Process blowers
- Final clarifiers
- Activated sludge pumps
- Primary sludge pumps
- Lime system
- Chlorination system

Due to the age of the equipment, plant staff address major equipment failures, such as a final clarifier drive, in a reactive manner rather than a proactive manner. Replacement of such critical equipment unexpectedly causes great disruption to operations, compromises the reliability of the treatment services, and can be more costly than taking a proactive approach. The proposed improvements are necessary to ensure the continued reliability of sanitary service and will address aging infrastructure that presents a health and sanitation risk to the residents of Grand Ledge. These improvements are intended to maintain the existing infrastructure, provide resilient sanitary service, and protect the natural features within the community. The improvements will mitigate the risk of SSOs directly into the Grand River and provide redundancy to allow for condition evaluation, maintenance, and repairs.

## **2.0 Analysis of Alternatives**

### **2.1 Identification of Potential Alternatives**

The following treatment alternatives were developed considering this design criteria:

- Alternative 1 – No Action
- Alternative 2 – Optimization of Existing Facilities: Expansion of Conventional Activated Sludge
- Alternative 3 – Optimization of Existing Facilities: Conversion to Extended Aeration
- Alternative 4 – Optimization of Existing Facilities: Conversion to Membrane Bioreactors (MBRs)
- Alternative 5 – Regional Alternative: Connection to Existing Regional WWTP
- Alternative 6 – Regional Alternative: Construction of New Satellite WWTP

Current improvements are based on meeting full projected flow and load. Consideration has been given to each alternative's ability to be built in phases, as needed to meet existing treatment and future treatment requirements. An in-depth analysis for each principal alternative includes a monetary evaluation, an Implementability assessment, an evaluation of potential environmental impacts, and an evaluation of technical differences between alternatives.

#### **2.1.1 Alternative 1 – No Action**

Alternative 1 would maintain the existing mode of operation for the sanitary sewer system and the WWTP. Alternative 1 would not involve capital expenditure and would not have construction impacts to Fitzgerald Park. Due to current sanitary sewer system, WWTP capacity limitations, WWTP equipment age, and the projected flow and loading increases, Alternative 1 is not considered a principal alternative and will not be considered further.

### **2.1.2 Alternative 2 – Optimization of Existing Facilities: Expansion of Conventional Activated Sludge**

Alternative 2 would expand the treatment capacity while maintaining the current mode of conventional activated sludge biological treatment. Under Alternative 2, the following improvements would be required to provide the basis of design treatment capacity:

#### Flow Retention

- 150-foot-long by 80-foot-wide concrete basin with 25-foot sidewalls near solids storage area.
- Force main connecting raw influent to retention basin.
- Pumps to transfer raw influent through force main.
- Gravity sewer connecting retention basin to headworks.

#### Preliminary Treatment

- Demolish existing aerated grit system and building.
- Relocate new vortex grit to south side of site.

#### Primary Clarification

- Demolish existing primary clarifier mechanical equipment.
- Construct two 70-foot-long by 20-foot-wide rectangular primary clarifiers on east side of site.

#### Aeration System

- Convert existing primary clarifiers to aeration tanks.
- Four 50-foot-long by 25-foot-wide aeration tanks constructed in place of demolished final clarifiers.
- Process and sludge piping.
- Replacement of blowers in Process Building.

#### Final Clarifiers

- Demolish existing final clarifiers.
- Two 60-foot-diameter clarifiers in Fitzgerald Park.

#### Disinfection and Outfall

- Decommission existing chlorine disinfection system.
- Ultraviolet (UV) disinfection system on west end of the site.
- Construct new plant effluent pipe to discharge downstream of the low head dam in the Grand River.
- New outfall to be permitted by EGLE.

#### Solids Handling

- Two rotary drum thickeners and associated piping and equipment modifications to reduce biosolids volume.
- Bulk lime storage and lime handling equipment for biosolids stabilization.

Alternative 2 improvements are identified in Figure 13. Construction of Alternative 2 would require utilization of approximately 1.3 acres of Fitzgerald Park. Alternative 2 meets the project objectives, is considered a principal alternative, and will be evaluated further.

### **2.1.3 Alternative 3 – Optimization of Existing Facilities: Conversion to Extended Aeration**

Alternative 3 would expand the treatment capacity by converting the treatment process to provide extended aeration biological treatment. While this treatment is very similar to the current conventional activated sludge

treatment, an extended hydraulic retention time in the treatment tanks allows for nitrification treatment. Under Alternative 3, the following improvements would be required to provide the basis of design treatment capacity:

#### Flow Retention

- 150-foot-long by 80-foot-wide concrete basin with 25-foot sidewalls near the solids storage area.
- New force main connecting raw influent to retention basin.
- Pumps to transfer raw influent through force main.
- New gravity sewer connecting retention basin to headworks.

#### Grit Removal

- Demolish existing aerated grit system and building.
- Build new vortex grit system.

#### Primary Clarification

- Demolish existing primary clarifier mechanical equipment.
- Convert to aeration tanks upstream of new extended aeration tanks.

#### Aeration System

- Convert existing primary clarifiers to aeration tanks.
- Build three 100-foot-long by 50-foot-wide extended aeration tanks with 24-foot sidewalls in Fitzgerald Park.
- Site piping modifications and pumping systems to and from the additional aeration tanks.

#### Final Clarifier

- Build one new 65-foot-diameter clarifier.
- Site piping modifications for flow split between clarifiers.

#### Disinfection and Outfall

- Decommission existing chlorine disinfection system.
- Build new UV disinfection system on west end of the site.
- Construct new plant effluent pipe to discharge downstream of the low head dam in the Grand River.
- New outfall to be permitted by EGLE.

#### Solids Handling

- Two rotary drum thickeners and associated piping and equipment modifications to reduce biosolids volume.
- Bulk lime storage and lime handling equipment for biosolids stabilization.

Alternative 3 improvements are identified in Figure 14. Construction of Alternative 3 would require approximately 1.4 acres of additional space within Fitzgerald Park and will entail some area disturbed for new piping to and from the new flow retention basin near the current solids storage area. Alternative 3 meets the project objectives, is considered a principal alternative, and will be evaluated further.

### **2.1.4 Alternative 4 – Optimization of Existing Facilities: Conversion to MBR**

Alternative 4 would expand the treatment capacity by converting to an MBR treatment process. The primary clarifiers would be replaced with microscreens to provide primary sludge removal. The conventional activated sludge secondary treatment system would be converted into an MBR treatment system allowing for the elimination of the final clarifiers. This is a significant change to the treatment process; however, these progressive technologies can produce a very high-quality effluent in a reduced footprint. Under Alternative 4, the following improvements would be required to provide the basis of design treatment capacity:

### Flow Retention

- 150-foot-long by 80-foot-wide concrete basin with 25-foot sidewalls in Fitzgerald Park.
- New force main connecting raw influent to retention basin.
- Pumps to transfer raw influent through force main.
- New gravity sewer connecting retention basin to headworks.

### Preliminary Treatment

- Demolish existing aerated grit system and building.
- Relocate new vortex grit to south side of site.
- Construct a 30-foot by 40-foot building addition to the headworks building.

### Primary Treatment

- Demolish existing primary clarifiers.
- Install microscreens for MBR protection and to replace primary clarifiers.

### MBR System

- Three trains of membranes in existing final clarifiers.
- Update aeration system as needed for MBR biological treatment.
- Decommission existing final clarifiers and demolish mechanisms.

### Disinfection

- Decommission existing chlorine disinfection system.
- Build new UV disinfection system within the existing chlorine contact tanks.

### Solids Handling

- Two rotary drum thickeners and associated piping and equipment modifications to reduce biosolids volume.
- Bulk lime storage and lime handling equipment for biosolids stabilization.

Alternative 4 improvements are identified in Figure 15. Construction of Alternative 4 would require less than 1 acre of Fitzgerald Park and will entail that some area be disturbed by new piping to and from the new flow retention basin. Alternative 4 meets the project objectives, is considered a principal alternative, and will be evaluated further.

## **2.1.5 Alternative 5 – Regional Alternative: Connection to Existing Regional WWTP**

The most practical regional alternative would be provided by connecting to either the Southern Clinton County Municipal Utility Authority (SCCUMA) WWTP in DeWitt or the Delta Township WWTP.

The SCCUMA WWTP is located approximately 9.5 miles from the Grand Ledge WWTP. Based on a potential route, a 12.4-mile force main could be required to make this regional connection. Additional improvements within the SCCUMA sanitary sewer system may be required to route flow to the SCCUMA WWTP. The existing SCCUMA WWTP has a rated capacity of 5.0 mgd. This rated capacity is anticipated to serve the growing needs of Bath Township, DeWitt Township, Watertown Township, and the City of Dewitt past the year 2030. Adding flow from Grand Ledge could necessitate improvements to the SCCUMA WWTP sooner than currently anticipated. Given the distance and capacity limitations, connection to the SCCUMA WWTP is a not a viable alternative.

The Delta Township WWTP is located approximately 5.5 miles from the Grand Ledge WWTP and the Delta Township sanitary sewer system is located such that an approximate 3.3-mile force main would be required to make this regional connection. Additional improvements within the Delta Township sanitary sewer system may be required to route flow to the Delta Township WWTP. The Delta Township WWTP is currently in the process of

expanding their facility. The existing facility has a rated capacity of 6.0 mgd, while the proposed improvements are intended to expand the capacity to 8.0 mgd. Currently, the Delta Township WWTP receives an annual average flow of 4.9 mgd. The increase in the Delta Township WWTP rated capacity is to accommodate the projected 30-year growth within their existing service area and does not include accommodations for additional flow from Grand Ledge.

Considerations beyond the physical limitations of connecting to a regional alternative must be evaluated. By connecting to a regional alternative, Grand Ledge would not be able to control the future cost of treatment, or the rates assessed to users within the Grand Ledge service area. Additionally, future connections to or expansions of the Grand Ledge service area may need to be approved by the regional authority. If treatment capacity is limited, future connections could be denied. This could limit growth within Grand Ledge. Maintaining autonomy and control over future costs are important factors in creating a prosperous future in Grand Ledge. Given the distance, limited capacity, and the potentially restrictive nature of a regional approach, Alternative 5 is not considered a principal alternative and will not be evaluated further.

### **2.1.6      *Alternative 6 – Regional Alternative: Construction of New Satellite WWTP***

Alternative 6 would maintain the capacity of the existing WWTP and provides additional capacity at a second remote WWTP located near the anticipated growth within the industrial park. While significant improvements would not be required currently at the existing WWTP, substantial sanitary sewer system improvements would be required to redirect flow to the remote WWTP site. In addition, loading to the remote WWTP would be low until growth within the industrial park is realized. Once growth within the industrial park is realized, the remote facility would be highly dependent upon loading from a small number of industrial users. This underloading and potential future variable loading could create significant operational difficulties.

This remote facility could potentially discharge to the Whitney Drain, a small tributary of the Grand River. Given this potential discharge location, the effluent limits for the remote facility would be very restrictive and necessitate a high degree of reliable treatment. Providing a facility able to meet such treatment requirements may be cost prohibitive.

By introducing a remote facility, the City would need to maintain compliance with its existing NPDES permit at the current WWTP and would also need to maintain compliance with a new NPDES permit at the remote facility. Maintenance costs and system reliability would also be a concern in maintaining two WWTPs.

Given the loading concerns, the restrictive treatment requirements, the cost of construction, and the cost and logistical concerns associated with maintaining multiple facilities, Alternative 6 is not considered a principal alternative and will not be evaluated further.

### **2.1.7      *Water and Energy Efficiency***

Water and energy efficiency have been considered while determining the selected alternative. A further explanation of the potential for water and energy efficiency with the selected alternative is provided with the relevant design parameters for the selected alternative.

## **2.2      *Sanitary Sewer System Improvements***

To properly size WWTP improvements, sanitary sewer system improvements will be required. Since the interceptor along the Grand River between the WWTP and the WRPS runs along the ledges, it is not possible to increase its capacity by replacing it with a larger sewer. The primary viable alternative for transporting more flow to the WWTP is to install larger pumps at the WRPS and installing a new force main along Grand River Avenue directly to the proposed RTB at the WWTP. The WRPS will likely require larger pumps. Final pump sizing will be based on flow monitoring and modeling.

Structural deficiencies in the existing clay sanitary sewer in Green Street from Seminary Street to South Street have resulted in localized I/I. This section of sanitary sewer should be replaced to address the structural deficiencies and to help reduce I/I.

The following are the anticipated sanitary sewer system improvements:

- New pumps in the space provided at WRPS with a firm wet weather capacity of 1,500 gpm (estimated).
- Approximately 7,000 lineal feet of 12-inch PVC (polyvinyl chloride) force main from WRPS to the new retention basin at the WWTP, including a jack a bore of the railroad, and 5,300 lineal feet along the road including restoration.
- Replacement of approximately 868 feet of 8-inch gravity sewer along with sanitary sewer service replacement and restoration in Green Street from Seminary Street to Green Street.

### 2.3 Analysis of Principal Alternatives

The alternatives analysis identified Alternatives 2, 3, and 4 as principal alternatives. The following section provides the monetary evaluation, environmental evaluation, and evaluates other technical aspects for the principal alternative.

#### 2.3.1 Monetary Evaluation

A monetary evaluation has been completed for the principal alternatives using a 20-year net present worth analysis. A present worth analysis evaluates the total cost of treatment of each principal alternative by evaluating its 20-year life cycle cost. This net present worth analysis includes an evaluation of the capital cost for construction, the operation, maintenance, and replacement (OM&R) costs and the salvage value for the proposed improvements.

OM&R costs account for labor costs, supply and chemical costs, utility costs, maintenance costs, and additional expenses required to operate and maintain the proposed facility. The present worth for 20 years of OM&R costs are included in the analysis. A real discount rate of 0.5% has been assumed for this analysis.

Salvage values for the proposed improvements are included in the net present worth analysis. Items included in the current project will retain value at the end of the design life of the project and may continue to provide value. The present worth of the salvage value is included in the net present worth analysis, again assuming a real discount rate of 0.5%.

In general, the alternative with the lowest net present worth can be viewed as the alternative that provides the lowest cost of treatment. All principal alternatives are intended to meet the current treatment requirements.

A summary table for the monetary evaluation is provided in Table 10. Each alternative includes the cost associated with the required sanitary sewer system improvements. Additional information on the monetary evaluation can be found in Appendix 6.

**Table 10 – Monetary Evaluation Summary**

Work Items	Alternative 2	Alternative 3	Alternative 4
Capital Cost	\$45,991,000	\$47,980,000	\$34,9993,000
Annual OM&R Cost	\$897,507	\$1,021,995	\$1,117,049
Salvage Value	\$15,028,800	\$16,800,000	\$10,279,800
Present Worth of 20 Years of OM&R Cost	\$17,042,000	\$19,406,000	\$21,210,000
Present Worth of Salvage Value	\$13,602,009	\$15,205,057	\$9,303,866
<b>20-Year Total Present Worth</b>	<b>\$49,350,991</b>	<b>\$52,180,943</b>	<b>\$46,899,134</b>

### 2.3.1.1 Sunk Costs

Sunk costs are the investments or financial commitments made before or during project planning. Sunk costs have not been included in the cost-effectiveness analysis since they have already been committed regardless of the alternative selected.

### 2.3.1.2 Present Worth

Present worth is the sum that if invested now at a given interest (discount) rate, would provide exactly the funds required to pay all present and future costs. Total present worth, used to compare alternatives, is the sum of the initial capital cost plus the present worth of OM&R costs minus the present worth of the salvage value at the end of the 20-year planning period. The summary of present worth values for the OM&R for the current operation and principal alternatives are provided in Table 11. Additional OM&R information can be found in Appendix 6.

**Table 11 – Projected OM&R Costs**

	Budget 2021-2022	Alternative 2	Alternative 3	Alternative 4
Labor	\$356,189	\$458,398	\$458,398	\$458,398
Maintenance Supplies	\$42,500	\$53,669	\$62,381	\$54,569
Chemicals	\$55,000	\$53,778	\$53,778	\$19,167
Contractual	\$80,000	\$80,000	\$80,000	\$80,000
Utilities	\$105,000	\$160,663	\$243,438	\$363,916
Maintenance	\$72,500	\$88,500	\$121,500	\$138,500
Transfer to Parks and Recreation	\$2,500	\$2,500	\$2,500	\$2,500
TOTAL	\$713,689	\$897,507	\$1,021,995	\$1,117,049
<b>Present Worth of 20 Years of OM&amp;R Costs</b>	<b>\$13,552,000</b>	<b>\$17,042,000</b>	<b>\$19,406,000</b>	<b>\$21,210,000</b>

### 2.3.1.3 Salvage Value

The planning period for the monetary evaluation is 20 years. At the end of this period, portions of the proposed structures and equipment will have a salvage value. A straight-line depreciation has been used to calculate the salvage values for the principal alternatives. The present worth of the salvage value for the assets has been computed using the real discount rate. The present worth of the salvage value for each of the principal alternatives is shown in Table 10.

### 2.3.1.4 Escalation

The monetary evaluation allows for energy costs and land values to be escalated. The cost of labor, equipment, and materials is not escalated. For this monetary evaluation, energy costs have not been escalated and land values are not included in the evaluation.

### 2.3.1.5 Interest During Construction

Interest during construction is not anticipated to be significant and is not expected to influence the choice of alternatives. Interest has been calculated on a yearly basis.

### 2.3.1.6 Mitigation Costs

No mitigation costs are anticipated as part of the project.

### 2.3.1.7 User Costs

Alternative 4 is anticipated to cost an average sewer user \$40.78 per month. This cost impact does not include any potential principal forgiveness or the use of the existing sewer fund to offset project costs. Repayment of the estimated capital expense is anticipated to cost an average sewer user \$32.52 per month while impacts to OM&R

costs are anticipated to cost an average sewer user \$8.26 per month. Additional information on user costs is presented below.

### **2.3.1.8 Additional Monetary Considerations**

The future expandability of the proposed alternative is an important consideration. The site constraints observed at the existing location necessitate an efficient use of available space. Expanding Alternative 2 or Alternative 3 will require additional land for treatment plant use. Alternative 4 can continue to expand while maintaining the existing treatment plant footprint.

### **2.3.2 Partitioning the Project**

There is extensive and urgent need to complete the expansion of the WWTP and make improvements to the sanitary sewer system. Delay of these improvements could result in detrimental financial and environmental impacts. Partitioning the project is not recommended.

### **2.3.3 Environmental Evaluation**

All three principal alternatives will require expansion of the WWTP within Fitzgerald Park. Alternatives 2 and 3 will require more disturbance of park space than Alternative 4. Construction activities will have short-term environmental impact and a long-term impact by converting a portion of the park. Soil erosion and sedimentation control (SESC) will be used to mitigate impacts of excavation and construction vehicle traffic to the Grand River. Excavation will not affect the sandstone ledges.

All principal alternatives can meet the current effluent limits contained within the existing NPDES permit. Alternatives 2 and 3 may not provide as high a level of treatment as Alternative 4, due to the high level of solids separation provided by the membrane technology selected in Alternative 4. This higher level of treatment can provide a positive impact on the health of the receiving waters.

Energy and chemical use efficiency of the treatment processes will be considered to lessen the long-term environmental impact of the WWTP operation. Energy consumption for Alternatives 2 and 3 would be less than Alternative 4. Conversely, anticipated chemical usage for Alternative 4 may be less than the anticipated chemical usage for Alternative 2 or Alternative 3.

### **2.3.4 Implementability and Public Participation**

The implementability restrictions for this project are minimal. The financial burden of the project will be manageable for Grand Ledge given the current state of the sewer fund. Intermunicipal agreements are not necessary for this project as the project serves the residents of Grand Ledge and the WWTP is owned and operated by the City.

The public has been and will continue to be provided with opportunities to comment on the project. Public concerns may be considered throughout the design and construction of the proposed improvements.

### **2.3.5 Technical and Other Considerations**

#### **2.3.5.1 I/I Removal**

I/I is defined as clear water entering the system during wet weather or high groundwater conditions. In certain instances, I/I removal may be cost-effective compared to the operational costs for transport and treatment of the clear water. An evaluation of the level of I/I in the sanitary sewer system has been conducted. I/I causes high flow in the sanitary sewer system during storm events and during times of high AMC. Storm events can result in overflows in the sanitary sewer system and discharges from the RTB.

Ongoing flow monitoring is being used to complete an I/I analysis. Initial findings show that sanitary sewer system improvements are required to address the ongoing overflows from the sanitary sewer system and that additional

influent flow equalization at the WWTP is required to avoid discharges from the existing retention treatment basin during a design storm event. Removing sufficient I/I from the sanitary sewer system as required to avoid SSOs and limiting discharges from the existing RTB is not cost-effective and would not address the violation notice issued by EGLE. SSOs may persist until proposed improvements intended to transport and treat existing I/I are implemented. I/I removal will continue to be pursued through ongoing collection system improvements, such as the proposed sanitary sewer replacement in Green Street.

#### **2.3.5.2 Structural Integrity**

Structural sewer problems in the sanitary sewer system are not suspected to be a widespread problem. The sanitary sewer system was evaluated as part of a recently completed sanitary sewer systems AMP. The National Association of Sewer Services Companies Pipeline Assessment Certification Program grading system was used to define the severity of pipe defects. The sanitary sewer system AMP will be made available upon request.

The clay sanitary sewer pipe in Green Street between Seminary Street and South Street has structural deficiencies. These deficiencies have resulted in high levels of I/I in the area. The City intends to continue to replace aging sanitary sewer pipes as structural deficiencies develop.

#### **2.3.5.3 Sludge Residuals**

The Grand Ledge WWTP currently produces lime stabilized biosolids and utilizes liquid land application for ultimate disposal. Alternatives 2 and 3 are anticipated to produce similar volumes of biosolids of similar quality to what is currently being produced. Alternative 4 will produce less biosolids by eliminating the primary clarifiers from the treatment process. Conversely, the finer screening requirements of Alternative 4 will result in larger volumes of material removed during preliminary treatment. Screened material in Alternative 4 would likely be disposed of in a landfill.

#### **2.3.5.4 Industrial Pretreatment**

There is no industrial pretreatment program. There are no categorical users that have implemented a pretreatment program. Pretreatment requirements may be considered for future industrial users.

#### **2.3.5.5 Growth Capacity**

The capacity of the proposed facilities under all principal alternatives consider the wastewater needs during the 20-year planning period. A balance has been struck between building facilities for the entire planning period and building facilities that will require expansion in less than 20 years.

#### **2.3.5.6 Areas Currently Without Sewers**

There are no specific intentions of expanding the existing sewer district. On a case-by-case basis, sanitary sewer service may be extended to areas upon the request of landowners. The current Sewer District represents the 20-Year Study Area.

#### **2.3.5.7 Reliability**

Each principal alternative has been evaluated based on its ability to meet and consistently maintain permit limitation throughout the useful life of the project. All principal alternative improvements would meet the USEPA reliability requirements for wastewater treatment plants. Alternative 4 provides the best overall system reliability of the alternatives evaluated in terms of its ability to meet and consistently maintain permit compliance throughout the useful life of the project.

#### **2.3.5.8 Alternative Sites and Routings**

Because of the existing sanitary sewer system and treatment infrastructure already in place, relocating the existing treatment plant was found to be infeasible.

### **2.3.5.9 Combined Sewer Overflows**

The sanitary sewer system for the Grand Ledge WWTP is a separated system and does not have any combined sewer overflows (CSOs). Sewer separation work has generally been effective at separating the storm sewer system from the sanitary sewer system. I/I, largely from building footing drains remains an ongoing issue which can result in SSOs from the sanitary sewer system and discharges from the existing RTB. Continuing to eliminate I/I has proven to be difficult. Additional equalization capacity and sanitary sewer system improvements to handle I/I have been incorporated into the principal alternatives. These improvements are intended to address SSOs in the sanitary sewer system.

### **2.3.5.10 Contamination at the Project Site**

Typically, four types of contamination may be encountered during project construction: soils contaminated by petroleum or other chemicals; discarded materials such as chemical drums or insulation; groundwater or surface waters contaminated by chemical leachate or runoff; and materials to be removed or disturbed in the existing facility that contain asbestos, lead, mercury, PCBs (polychlorinated biphenyls), or similar contaminants.

A review of past activities at the site has not identified any activities that might have caused site contamination, such as leaking underground storage tanks. A visual survey of the project site did not identify any abandoned containers. No contamination is suspected at this time, and as such no soil or groundwater sampling has been conducted. An examination of the state's list of contaminated sites did not reveal any contaminated sites near the project.

### **2.3.5.11 Green Project Reserve (GPR)**

GPR funding is provided to address green infrastructure, water or energy efficiency improvements, or other environmentally innovative activities. Portions of the improvements included in Alternative 4 may be GPR eligible and may be eligible for partial principal forgiveness based on funding availability.

The proposed fine screening facility would reduce biochemical oxygen demand (BOD) and TSS loading to the secondary treatment process. By removing these materials prior to the secondary treatment process, overall energy consumption can be reduced, and additional aeration capacity would be required if these materials were not removed. Additionally, chemical usage in the secondary treatment process may be reduced by removing these materials prior to the secondary treatment process.

### **2.3.5.12 Land Requirements**

Each of the remaining alternatives will require additional land for construction within Fitzgerald Park area.

Alternative 2 will require approximately 1.3 acres for additional treatment area and will disturb an additional 0.3 acres for buried piping modifications.

Alternative 3 will require approximately 1.4 acres for additional treatment area and will disturb an additional 0.3 acres for buried piping modifications. The steep slope of the area south of the WWTP and the size of the proposed extended air tanks requires the Phase 2 tank to be constructed adjacent to the existing biosolids storage tank in the biosolids handling area. This would require further air piping, process water piping, and sludge piping. This alternative requires the largest expansion footprint.

Alternative 4 will require less than 1 acre for additional treatment area, including the grass hill and the gravel parking lot west of the WWTP.

### **2.3.5.13 Potential Construction Problems**

Continuing existing WWTP operation is the main concern when decommissioning or demolishing treatment cells. To remove a tank, the replacement tank and process piping or a temporary bypass must already be in place. Phase 1a construction for all alternatives will need to be coordinated to allow for uninterrupted treatment. Yard

piping protection, when converting and constructing treatment tanks, will be essential to uninterrupted service. A detailed survey of yard piping is needed during design to determine the allowable footprint of new tanks and the alignments of new piping.

There will be natural factors to contend with during construction such as the steep grade across the site and Fitzgerald Park, as well as the bedrock that exists close to grade. The steep grade will necessitate the need for pumps to reach treatment that is built uphill and necessitates some of the extended aeration tanks in Alternative 4 to be built further into Fitzgerald Park. Increased difficulty of excavation into bedrock for tanks, building additions, or piping must be considered during cost and schedule estimation. These factors will dictate the future site plan and impact the construction cost.

With the current supply chain issues, volatile material pricing, and uncertain labor availability experienced across the country, the estimates provided in this report are less certain than before the Covid-19 pandemic. It is unclear if these issues will have resolved or worsened by the time construction of Phase 1a would begin.

## 3.0 Selected Alternative

Based on a detailed evaluation, Alternative 4 is the selected alternative. The following description of the selected alternative provides detail on the project and discusses the benefits as well as its adverse impacts. An explanation of how the proposed project fits into comprehensive plans to address wastewater for the planning period is included in the sections below.

### 3.1 Relevant Design Parameters

#### 3.1.1 Retention Basin

Influent flow retention is required to address I/I and limit discharges from the existing RTB. The existing RTB does not provide adequate influent flow equalization to prevent peak flow capacity concerns at the WWTP. A new retention basin will be constructed to retain the peak wet weather flow and reduce the peak hourly flow design requirement of the downstream processes such as the new preliminary treatment, primary treatment, and MBR system. The retention basin will be sized to handle the flow above the design maximum day flow of 7.9 mgd.

A new force main from the WRPS will be directed to the new retention basin. Additionally, pumps will be installed in the existing RTB to direct excess flow to the new retention basin and a gravity drain from the retention basin will be routed back to the headworks. The new retention basin will be in Fitzgerald Park and is planned to be approximately 150-foot-long by 80-foot-wide with 25-foot sidewalls in Fitzgerald Park. Wet weather flow monitoring is currently underway to determine the volume of retention required. Historic data has been used to provide preliminary sizing. The retention basin will include required level monitoring and flushing system.

#### 3.1.2 Preliminary Treatment

The existing aerated grit chamber is ineffective and requires frequent manual removal of grit. Because the grit removal system is ineffective, the downstream processes are currently adversely impacted. A new vortex grit removal system will be installed to reduce the maintenance requirements, improve grit removal, and lower the energy consumption of this unit process. The proposed system will include one vortex chamber rated for an average flow rate of 3.9 mgd and a peak flow rate of 7.9 mgd. This will vastly improve grit removal effectiveness and operational efficiency across the WWTP. The grit removal system will include a vortex grit tank, grit pump, grit classifier, and a bypass channel. The grit pump and grit classifier will be housed in a building equipped with proper heating, ventilation, and gas detection systems as required by National Fire Protection Association (NFPA) 820.

### **3.1.3 Primary Treatment**

Primary treatment is currently accomplished in two rectangular primary clarifiers. Alternative 4 will replace the primary clarifiers with microscreens designed to have comparable removal efficiencies for BOD and TSS to those currently observed in the primary clarifiers. The microscreens also prevent fouling and extend the useful life of the membranes used in the MBR system. This allows for the elimination of the existing primary clarifiers. The microscreens will be housed in a building that will allow for the efficient collection and disposal of screened material. The screening system will be sized for the design average and equalized design peak instantaneous flow. The building will be equipped with proper heating, ventilation, and gas detection systems as required by NFPA 820.

### **3.1.4 MBR System**

Alternative 4 will convert the existing secondary treatment process into an MBR treatment process. The existing aeration tanks and blowers will be modified to facilitate MBR biological treatment. The existing primary clarifiers will be modified to house additional aeration capacity and to house membrane modules and pumping equipment. The existing final clarifiers would be decommissioned since the MBR process does not require final clarifier tanks. Aeration systems would be sized to provide treatment for the design peak hour loading.

### **3.1.5 Disinfection**

The existing chlorine disinfection system equipment is aging, poses safety risks, and can be difficult to operate. Alternative 4 includes conversion of the existing chlorine contact tank to a UV disinfection system. Disinfected plant effluent will continue to be discharged through the existing outfall to the Grand River.

### **3.1.6 Solids Handling**

Primary and secondary waste solids are lime stabilized to create Class B biosolids, stored, and disposed of through a liquid land application program. Decant from the biosolids storage tanks is manually returned to the head of the plant to accommodate biosolids thickening. Currently, individual sacks of lime are manually loaded into feed equipment for dosing. The existing system is labor intensive and poses health and safety concerns. Alternative 4 includes the addition of rotary drum thickeners, associated piping, pumps, and equipment modifications along with new bulk lime storage and lime handling equipment. The drum thickeners will help reduce the volume of biosolids by separating water from the waste activated sludge stream prior to lime stabilization. This will help control lime use. Bulk lime storage and lime handling equipment will help improve operations and operator safety. Because Alternative 4 eliminates the primary clarifiers, solids handling will be sized to address anticipated waste sludge production.

### **3.1.7 Electrical Improvements**

Electrical needs will be addressed throughout the WWTP. Existing MCCs (motor control centers), distribution equipment, and standby power systems may be updated as required to accommodate modifications and expansion of the existing system.

### **3.1.8 Site Improvements**

The area around the proposed retention basin will be improved to maintain the area for use within Fitzgerald Park. A walking trail will be provided so that river access may be maintained during construction. Public facilities may be incorporated into the retention basin.

### **3.1.9 Building Modifications**

The existing buildings throughout the WWTP are in fair condition but may require mechanical upgrades associated with planned improvements. Existing doors, windows and flooring systems may need to be replaced to accommodate the proposed improvements.

#### **3.1.10 Sanitary Sewer System Improvements**

Additional pumping capacity will be installed in the WRPS to address high flow that results from I/I during wet weather events. A new sanitary force main will be installed from the WRPS to the proposed retention basin at the WWTP site to allow for hydraulic relief of the gravity sewer along the Grand River from the WRPS to the WWTP and to transport and treat I/I.

The sanitary sewer in Green Street from Seminary Street to South Street will be replaced to address structural deficiencies and help reduce I/I. Sanitary sewer laterals will be replaced to further reduce I/I. Sanitary manholes will be installed along the gravity sewer.

## **3.2 Project Maps**

Figure 16 depicts the proposed site location for the proposed improvements including the sanitary sewer system improvements. Elements of this layout may change through the detailed design phase. These layouts will all be modified through the detailed design process.

## **3.3 Controlling Factors**

The selected alternative is intended to provide treatment for the 20-year projected service area population, as discussed in Section 1.4, and the associated 20-year design flows and loads discussed in Section 1.8.5. The selected alternative is intended to meet the discharge permit requirements set in the current NPDES permit. EGLE has issued a Violation Notice (Appendix 4). The proposed improvements are intended to address the issues identified in this Violation Notice.

Electrical and mechanical upgrades will be designed to meet Class I Division 1 requirements (NFPA 70 – NEC, 820 – WWTP) in applicable areas to provide safe lighting and ventilation to the station. Electrical and mechanical upgrades in unclassified areas will be designed to provide safe entry and operation by WWTP personnel. Construction is limited to the confines of the existing WWTP footprint and the parking lot of Fitzgerald Park. The site is limited by the Grand River and the Grand Ledges to the north and west, Fitzgerald Park to the south and east. Possible expansion of the facility outside the area listed in the project description is not currently feasible. The WWTP should visually integrate into the surroundings and limit odor production that may impact activities in Fitzgerald Park.

## **3.4 Special Assessment District Projects**

A Special Assessment District (SAD) will not be created as a part of the project. As the proposed improvements are for the benefit of all sewer users within the sewer district, the creation of a SAD will not be necessary.

## **3.5 Sensitive Features**

Environmentally sensitive features such as wetlands, floodplains, prime or unique agricultural lands, archaeological sites, or threatened/endangered species were evaluated when assessing alternatives. The proposed project work will occur in the floodplain and will require an EGLE Part 31 Floodplain permit to move forward with construction. Additionally, the sandstone ledges prevalent in the area have been considered when developing and evaluating the principal alternatives. The proposed improvements of the selected alternative are not anticipated to have a negative impact on these sensitive features.

### 3.6 Schedule for Design and Construction

Many preliminary design tasks have been completed through past actions taken by the City. These past activities will allow the design for the proposed improvement to proceed upon completion of this Project Plan. See Table 12 for a summary of the design and construction activities schedule.

**Table 12 – Design and Construction Schedule**

Activities	Start Date	End Date
Design Engineering	June 2022	February 2023
Permitting	February 2023	March 2023
Bidding	March 2023	April 2023
Construction	June 2023	January 2026

Note that funding availability and permitting may impact the construction schedule. The project will require an Act 451 Part 41 Permit (Wastewater Construction) and an Act 451 Part 31 Permit (Floodplain).

### 3.7 Cost Summary

A high-level summary of the project cost is provided in Table 13. The detailed breakdown of the costs associated with planning, design, and construction of the selected alternative is included in Appendix 6. The total project cost of \$35 million represents the preliminary project cost at this time as detailed design and bidding has not yet been completed.

**Table 13 – Proposed Project Cost Summary**

Item	Estimated Cost
Sanitary Sewer System Improvements	\$2,941,000
Flow Retention	\$15,333,000
Preliminary Treatment	\$2,104,000
Primary Treatment	\$2,005,000
Biological Treatment	\$9,134,000
Final Clarification	\$280,000
Disinfection	\$1,515,000
Solids Handling	\$1,681,000
<b>Total Cost of Proposed Project</b>	<b>\$34,993,000</b>

### 3.8 Authority to Implement the Selected Alternative

Grand Ledge owns and operates the sanitary sewer system and WWTP facilities. The City owns the land on which the WWTP is located and has authority to implement the proposed improvements. The City is responsible for providing adequate wastewater treatment to its customers. With the support of the City’s staff and professional consultants, the City has the authority, capability, and willingness to plan, seek funding, finance, build, operate, and maintain the wastewater facilities.

### 3.9 User Costs

The costs associated with the total project cost are the responsibility of the City, and ultimately will be funded by user rates. Applying for SRF funding includes a low-interest 30-year loan that will help mitigate the increase in rates to the users. The City may qualify as a disadvantaged community and portions of the project are GPR eligible. There may be an associated principal forgiveness to offset user rate increases. Since principal forgiveness depends on the availability of grant funds and is not guaranteed, it is not used in the analysis on the impact of user costs.

To assess the effect of the proposed project on current user rates, the annual future costs based on the 30-year loan period were calculated based on the following assumptions.

- The total estimated project cost is \$34,993,000.
- The fiscal year 2022 SRF interest rate for a 30-year loan is set at 2.125%.
- The projected annual OM&R costs are \$1,117,049.

The monthly sewer bill of the average sewer user is anticipated to increase by \$40.78 per month, assuming no principal forgiveness and financing all of the estimated project cost with a low-interest loan through SRF. This is based on the repayment of the estimated capital expense and the estimated impacts to OM&R costs.

### 3.10 Disadvantaged Community

Part 53, Clean Water Assistance, of the Natural Resources Environmental Protection Act, 1994 PA 451, as amended, provides benefits to municipalities who meet the state’s criteria for disadvantaged community status. The City submitted the Disadvantaged Community Status Determination Worksheet with the Intent-to-Apply and is awaiting a final determination on its disadvantaged community status. The submitted Disadvantaged Community Status Determination Worksheet is provided in Appendix 7.

### 3.11 Useful Life

The proposed projects involve a variety of different assets including structural, mechanical, electrical, and process equipment. To determine the overall useful life of the projects, a weighted useful life was calculated using each individual dollar value multiplied by the individual useful life for each asset type, divided by the total estimated project cost. The useful life for the individual components is based on the SRF project guidance documentation. A summary of the costs and useful life for the major components of each project is provided in Table 14.

**Table 14 – Proposed Project Useful Life**

Proposed Improvement Activity	Activity Weighted Useful Life
Sanitary Sewer System Improvements	36.5
Flow Retention	41.3
Preliminary Treatment	30.5
Primary Treatment	13.4
Biological Treatment	22.1
Final Clarification	0.0
Disinfection	20.0
Solids Handling	34.3
<b>Overall Project Useful Life</b>	<b>32.1</b>

As indicated in Table 14, the composite useful life for the project is 32.1 years. The total useful life exceeds the 30-year loan term.

## 4.0 Evaluation of Environmental Impacts

Because this has been deemed a non-equivalency project, correspondence with the reviewing agencies was not required.

### 4.1 Direct Impacts

Direct impacts are the social and environmental impacts that are directly attributable to the construction and operation of the project. Direct impacts can be divided into those attributable to project construction, project operation, and social impacts.

### **4.1.1 Construction Impacts**

#### Environmental Setting

A portion of the work will occur in a floodplain and will be completed in accordance with local, state, and federal regulations. Impacts on other sensitive features are not anticipated as part of the proposed construction activities.

The proposed improvements are not expected to result in significant tree removal. Minor tree removal may be required for construction of the retention basin. This is not anticipated to result in the removal of large trees or extensive areas of vegetation removal.

Proposed improvements, including the retention basin, will be designed to allow for continued public access to the Grand River and the other environmental resources in Fitzgerald Park.

Rare, threatened, endangered, and special concern species have been identified in Section 1.3.2.12. It is not anticipated that construction activities will have a long-term impact on any of these species.

There are no known historical or archaeological sites that will be impacted by construction activities.

Groundwater dewatering is not anticipated to be necessary for construction activities. Short term impacts to the Grand River may be experienced, but mitigation efforts such as SESC measures will be taken to protect and prevent potential impacts to the surface water. Construction activities are not anticipated to impact groundwater. Drainage features or sidewalks will not be disturbed by the proposed construction activities.

#### Construction Methods

Construction activities normally create short-term impacts that can be mitigated or reversed through adequate restoration. No long-term, irreversible impacts are anticipated because of the proposed construction activities.

Construction activities will be predominately constrained to the existing WWTP site and the force main routing. No soils will be disposed of in, and no excess material will be stockpiled in a manner that will impact the Grand River.

#### Traffic Impacts

Construction activities usually create short-term impacts to traffic patterns. Construction hours for projects of this type are generally limited to 7:00 a.m. to 7:00 p.m. Monday through Friday, and 7:00 a.m. to 1:00 p.m. on Saturday. Vehicular and pedestrian access will be maintained throughout construction, including pedestrian access to the Grand River in Fitzgerald Park.

### **4.1.2 Operational Impacts**

Construction activities will impact operations. Project sequence of construction planning and coordination with the contractor will be required to maintain compliance with the existing NPDES permit requirements. Care must be taken during construction to mitigate potential odors that could result from process upsets, plan for required chemical deliveries, and allow construction access to the site.

### **4.1.3 Social Impacts**

Increased user costs are a social impact. Large increase in rates can create a negative impact. Some grant funding may be available to reduce the total construction cost and the impacts on user costs. Any potential grant funding has not been considered in the current economic analysis.

The construction phase of the projects will create temporary jobs and contribute favorably to the local economy. The proposed improvements will allow for continued operation and growth to sustain the local economy. A lack

of action would negatively impact the community by limiting current and future local development, thereby adversely impacting the economics of Grand Ledge and the region.

## 4.2 Indirect Impacts

The proposed projects will allow for future residential, commercial, and industrial development within the service area. The City does not anticipate a change in the rate, density, or type of residential, commercial, or industrial development that may occur within the service area as a result of the project. Future development is anticipated to be consistent with existing development in the area. The City does not anticipate changes in land use as a result of the proposed improvements. The proposed improvements are not anticipated to have an impact on air quality within the area. Water quality, especially in the Grand River, will be positively impacted by the proposed improvements. The City does not anticipate changes to the natural setting or to sensitive features resulting from secondary growth that may result from the proposed improvements. The proposed improvements may facilitate a positive impact on the economic resources within the area by promoting commercial and industrial development within the service area. The proposed project is not anticipated to have an indirect impact on area aesthetics.

## 4.3 Cumulative Impacts

Water quality improvements to the Grand River, both through the elimination of CSO events and through improved effluent quality, are the primary anticipated cumulative positive impacts.

## 5.0 Mitigation

Where adverse impacts cannot be avoided, structural and non-structural measures will be taken to avoid, eliminate, and mitigate adverse impacts on the environment. Structural measures include mitigation related to the design and construction of the facility. Non-structural measures include mitigation related to governmental, institutional, or private plans/policies/regulations as well as phasing of facility construction.

### 5.1 Short-Term Construction-Related Mitigation

The following are short-term construction impacts of the project and the associated mitigation measures:

- Construction operations will be limited to hours set by the City. Noise, odor, and dust will be kept to a minimum using SESC procedures established in the project plans and specifications.
- Standard methods for dust control such as water and/or calcium chloride application will be used during construction and restoration of vegetation.
- All ditches and lawns will be re-seeded and/or sodded. Care will be taken to only remove trees necessary for the construction. Vegetation that is removed as a part of the construction will be replaced.
- Any surplus or waste material resulting from construction will be disposed of properly in a suitable upland disposal site.
- When possible, areas will be restored to their existing grade.
- The proposed improvements taking place at the WWTP are adjacent to the Grand River. The project work will be confined to the area of work, and all precautions will be taken not to store, locate, or pile any construction materials near the Grand River.
- The proposed project will be located within the 100-year floodplain. No stockpiling of excess material will be allowed in the 100-year floodplain.

### 5.2 Mitigation of Long-Term Impacts

Every effort will be made to prevent long-term or irreversible impacts because of the project. The selected alternative has been evaluated to determine any potential of long-term impacts. Where long-term impacts are

unavoidable, mitigation measures will be considered to ensure that sensitive features do not suffer permanent or irreversible adverse impacts.

The long-term impacts of the short-term construction activities required to implement the proposed improvements are negligible, relative to the benefits to the environment and the community that the improvements will provide. Significant long-term impacts of the project have not been identified as there are no justifiable long-term impacts associated with the project.

### **5.2.1 Siting Decisions**

Alternative WWTP locations have been evaluated as a part of the selection process. Expanding the WWTP at the existing site was determined to be the preferable option. The proposed improvements have the fewest environmental impacts at the current WWTP location when compared to relocating the WWTP to other proposed locations.

### **5.2.2 Operational Impacts**

Historically, the existing WWTP has not received odor, aerosol, or noise complaints. While treatment upsets remain possible, the proposed improvements are not anticipated to result in any odor, aerosol, or noise issues. The proposed improvements provide redundancy and resiliency in the event of a WWTP upset. Chemicals used in the treatment process will be stored indoors in bulk storage tanks, and all chemical feed piping will be routed such that a break in the pipe will either drain to a treatment tank or to a secondary containment area, thereby mitigating the chance for a chemical spill. The use of chlorine for disinfection will be eliminated as part of the proposed improvements.

## **5.3 Mitigation of Indirect Impacts**

### **5.3.1 Master Plan and Zoning**

The City's existing master planning and zoning recognizes and aims to protect cultural, historical, and natural attributes existing in the study area. Residential development in existing neighborhoods and industrial development within the existing industrial park may be accommodated by the expansion of the treatment facility. Historical features, including the historic district within the City, will not be directly negatively impacted by construction activities, and will not be indirectly impacted by other infrastructure.

### **5.3.2 Ordinances**

Existing City ordinances will be enforced to control increased stormwater and non-point source pollution that may result as an indirect impact from development.

### **5.3.3 Staging of Construction**

Construction of sanitary sewer system improvements and WWTP improvements will be staged to limit indirect impacts. Construction of the retention basin must be complete before sanitary sewer system improvements allow for increased flow from the WRPS to the WWTP. Construction of grit removal equipment and fine screens must be complete before elimination of the primary clarifiers. MBR system improvements must be complete before the final clarifiers can be decommissioned. UV improvements should be completed after modifications to the MBR system.

## **6.0 Public Participation**

### **6.1 Public Meetings on Project Alternatives**

Community engagement is vital to maintain public trust and support. This is especially important as the existing WWTP is a prominent feature within Fitzgerald Park and includes access to a popular viewing platform on the Grand River. The park includes a trailhead to the geologically significant sandstone cliffs along the Grand River known as The Ledges.

### **6.2 The Formal Public Hearing**

#### **6.2.1 Public Hearing Advertisement**

The public hearing was advertised in the Grand Ledge Independent on March 20, 2022. The advertisement lists the public hearing date, describes the availability of the report for viewing, and briefly describes the proposed project and estimated costs. The Project Plan has been made available for public review and comment both on the City's website at [www.cityofgrandledge.com](http://www.cityofgrandledge.com) and at City Hall, 310 Greenwood Street, Grand Ledge MI 48837 on and after April 1, 2022. The advertisement is included in Appendix 8.

#### **6.2.2 Public Hearing Transcript**

A verbatim transcript of the public hearing will be transcribed by a stenographer from a recording of the proceedings and will be included in Appendix 9.

#### **6.2.3 Public Hearing Contents**

The Grand Ledge City Council will hold a public hearing during its regular meeting at 7:30 p.m. on May 9, 2022, in the Council Chambers, City Hall, 310 Greenwood Street, Grand Ledge MI 48837, to consider and receive public input. The following items will be discussed:

- A description of the water quality problems to be addressed by the project and the principal alternatives that were considered.
- A description of the recommended alternative, including its capital costs and a cost breakdown by project components (e.g., WWTP, sanitary sewer system).
- A discussion of project financing and costs to users, including the proposed method of project financing and estimated monthly debt retirement; the proposed annual, quarterly, or monthly charge to the typical residential customer; and any special fees that will be assessed.
- A description of the anticipated social and environmental impacts associated with the recommended alternative and the measures that will be taken to mitigate adverse impacts.

#### **6.2.4 Comments Received and Answered**

Appendix 9 will contain the minutes from the public hearing along with a typed list with the names and addresses of the people who attend the public hearing. Comments or questions received during the public comment period will receive written responses.

### **6.3 Adoption of the Project Plan**

The City intends to consider a resolution to adopt the final project plan during its May 9, 2022, City Council meeting. If questions of comments are received during the public hearing and need to be addressed, the proposed resolution may be considered at the May 23, 2022, City Council meeting. The resolution and the Clean Water State Revolving Fund (CWSRF) Project Plan Submittal Form will be included in Appendix 10.

# Figures

---

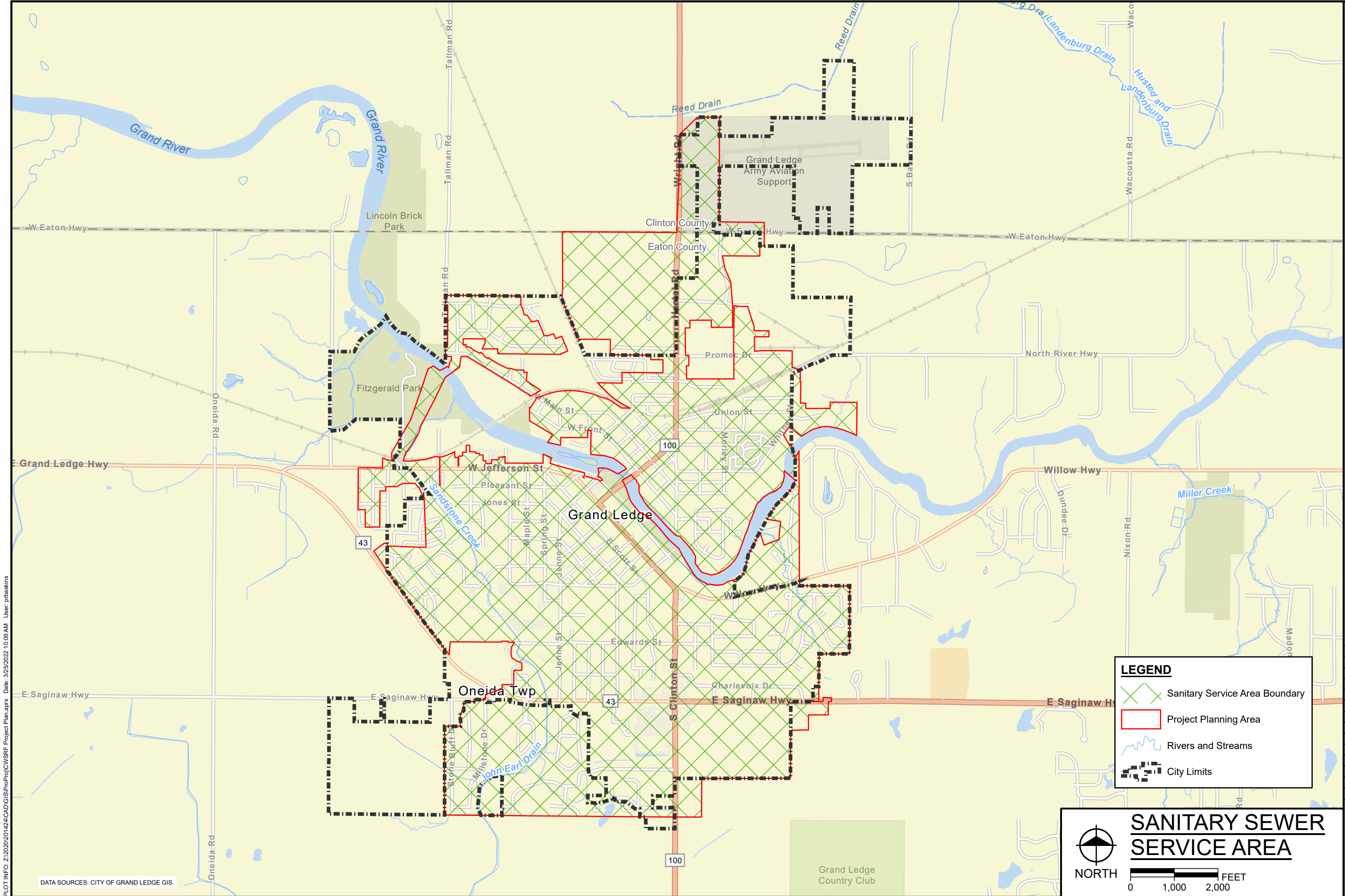

PLOT INFO: Z:\2020\201424\CAD\GIS\Proj\CWSRF Project Plan.aprx Date: 3/25/2022 10:09 AM User: pftaskins

DATA SOURCES: CITY OF GRAND LEDGE GIS.

**LEGEND**

- Sanitary Service Area Boundary
- Project Planning Area
- Rivers and Streams
- City Limits

**SANITARY SEWER SERVICE AREA**

NORTH

FEET



Hard copy is intended to be 11"x17" when plotted. Scale(s) indicated and graphic quality may not be accurate for any other size.

**City of Grand Ledge**  
Clinton County and Eaton County, Michigan  
**Clean Water State Revolving Fund (CWSRF) Project Plan**

PROJECT NO.  
201424

FIGURE NO.  
**1**

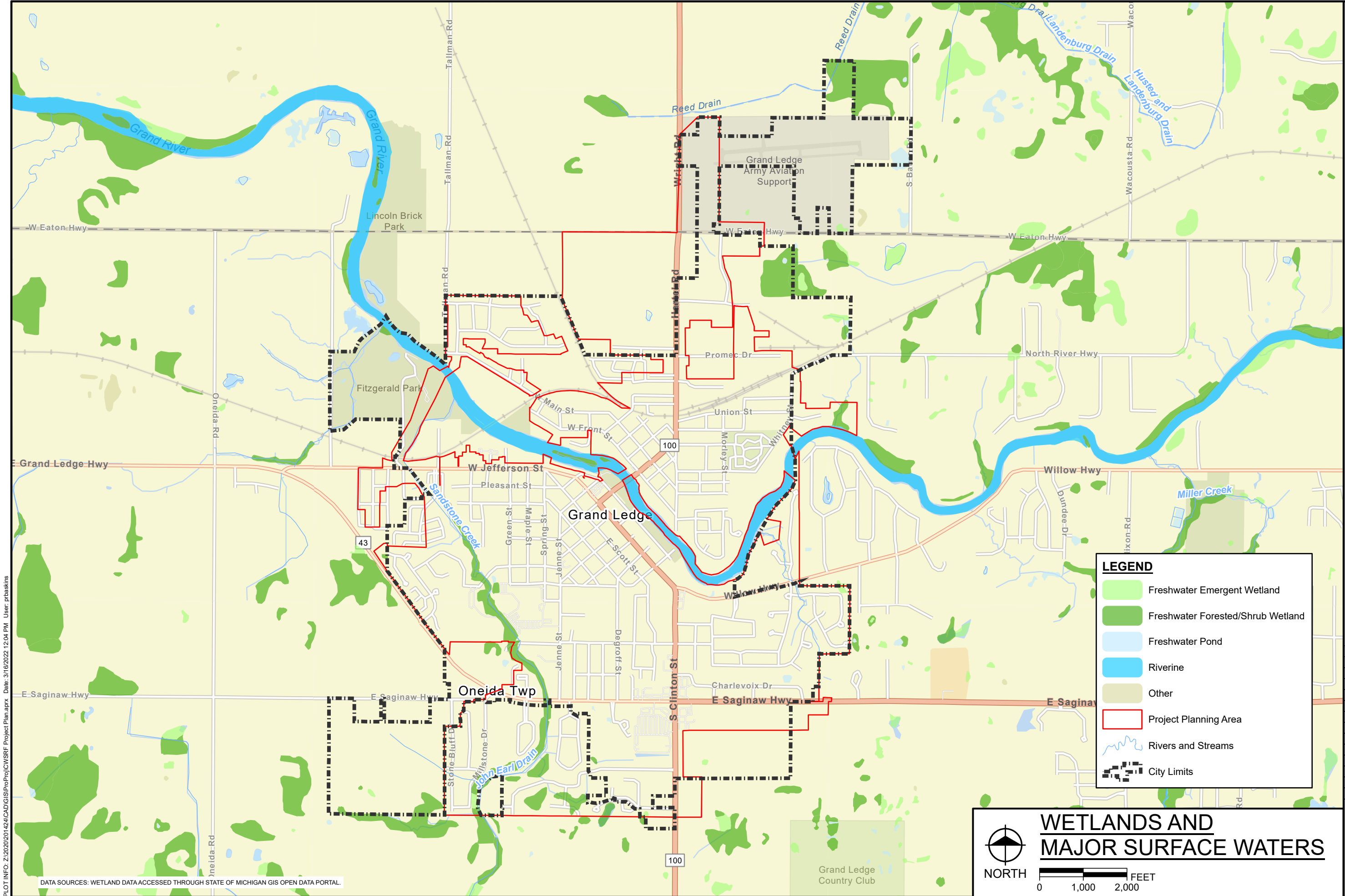

**LEGEND**

- Freshwater Emergent Wetland
- Freshwater Forested/Shrub Wetland
- Freshwater Pond
- Riverine
- Other
- Project Planning Area
- Rivers and Streams
- City Limits

**WETLANDS AND  
MAJOR SURFACE WATERS**

NORTH

FEET

PLOT INFO: Z:\2020\201424\CAD\GIS\ProProj\CWSRF Project Plan.aprx Date: 3/16/2022 12:04 PM User: prbaskins

DATA SOURCES: WETLAND DATA ACCESSED THROUGH STATE OF MICHIGAN GIS OPEN DATA PORTAL

©Copyright 2022 All Rights Reserved

Hard copy is intended to be 11"x17" when plotted. Scale(s) indicated and graphic quality may not be accurate for any other size.

PROJECT NO.  
201424

FIGURE NO.  
**2**

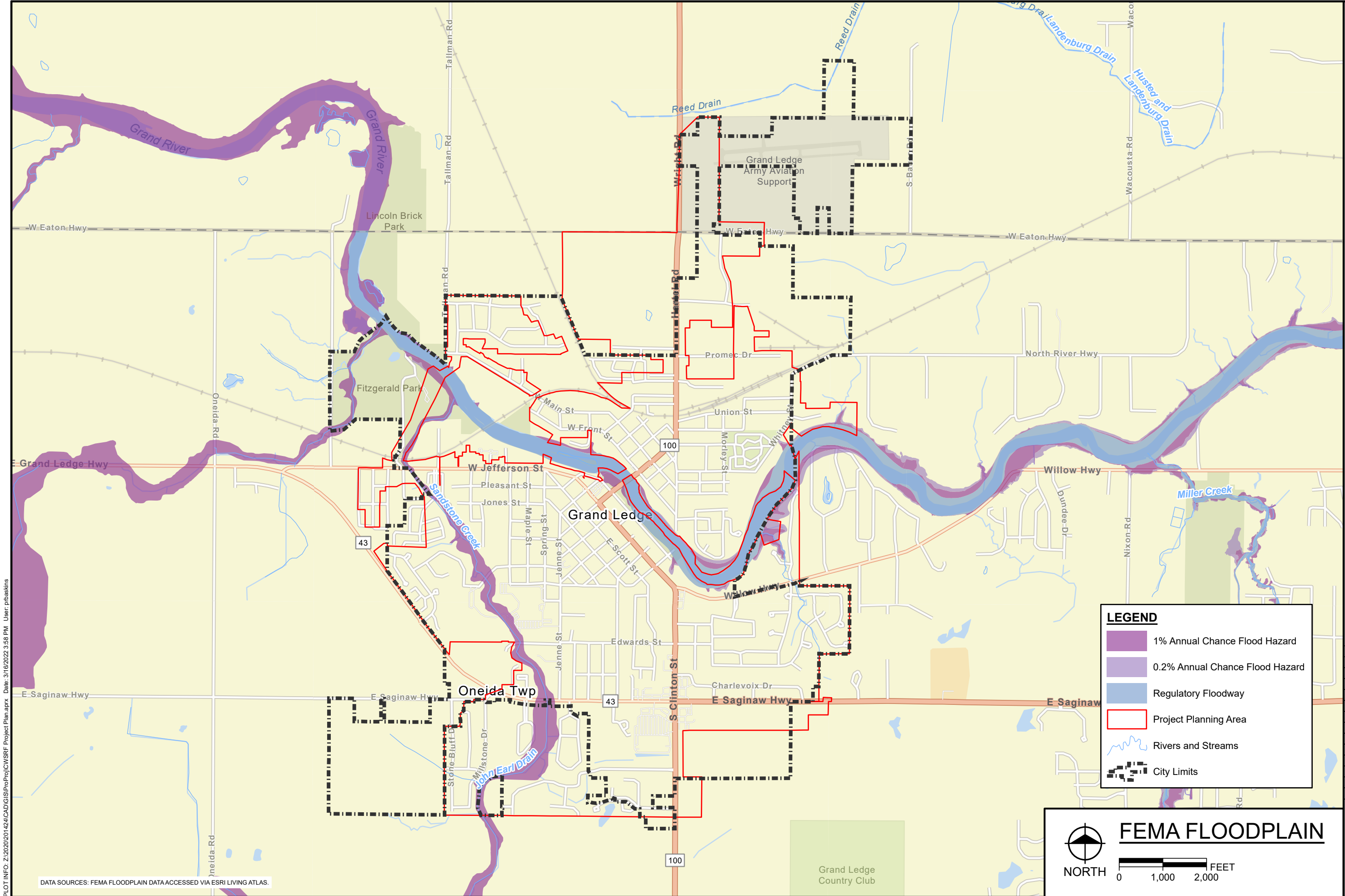

**LEGEND**

- 1% Annual Chance Flood Hazard
- 0.2% Annual Chance Flood Hazard
- Regulatory Floodway
- Project Planning Area
- Rivers and Streams
- City Limits

**FEMA FLOODPLAIN**

NORTH

0 1,000 2,000 FEET

DATA SOURCES: FEMA FLOODPLAIN DATA ACCESSED VIA ESRI LIVING ATLAS.

PLOT INFO: Z:\2020\201424\CAD\GIS\Proj\CWSRF Project Plan.aprx Date: 3/16/2022 3:58 PM User: pbbaskins

©Copyright 2022 All Rights Reserved

Hard copy is intended to be 11"x17" when plotted. Scale(s) indicated and graphic quality may not be accurate for any other size.

**FIGURE 4 - GRAND LEDGE PARK MAP**

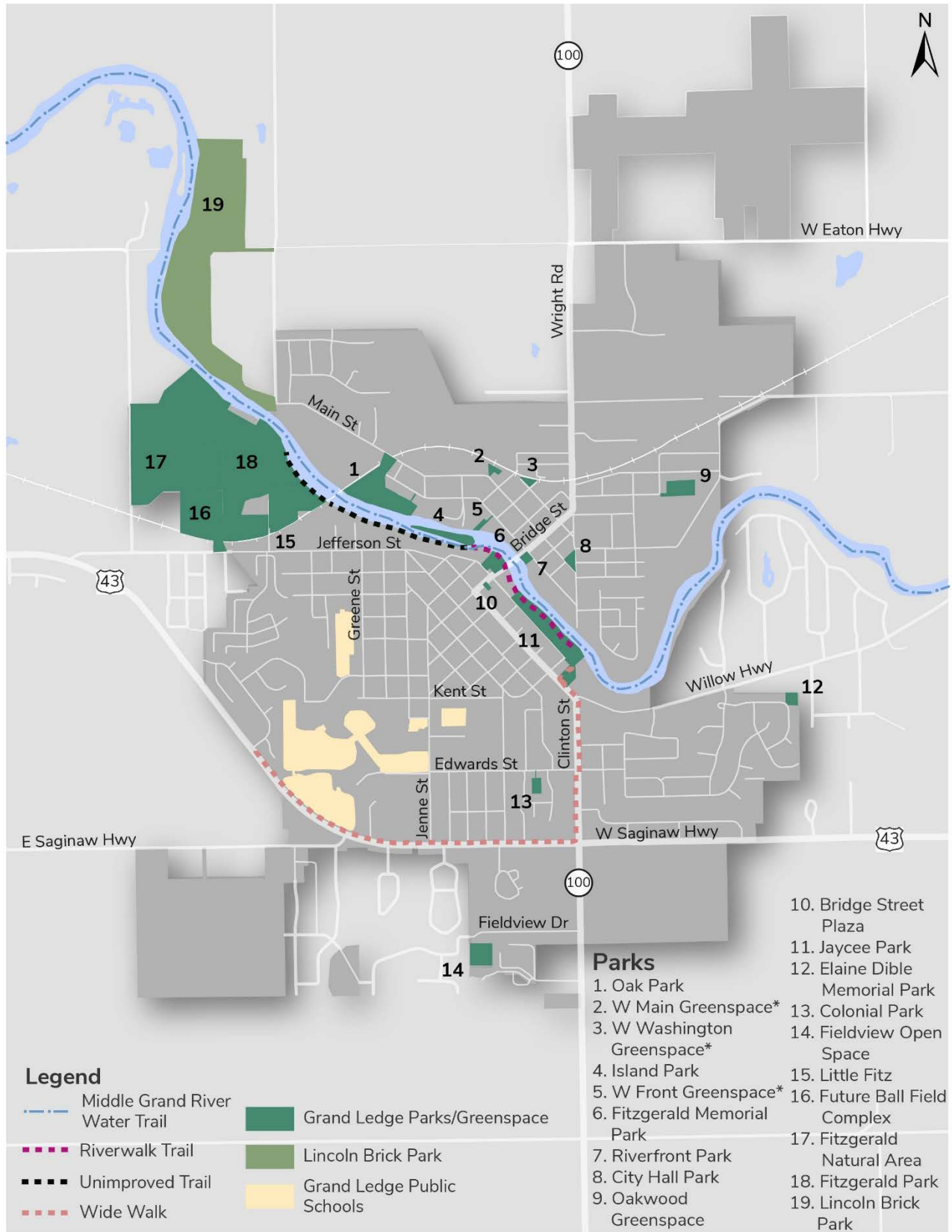

\* Future Greenspace

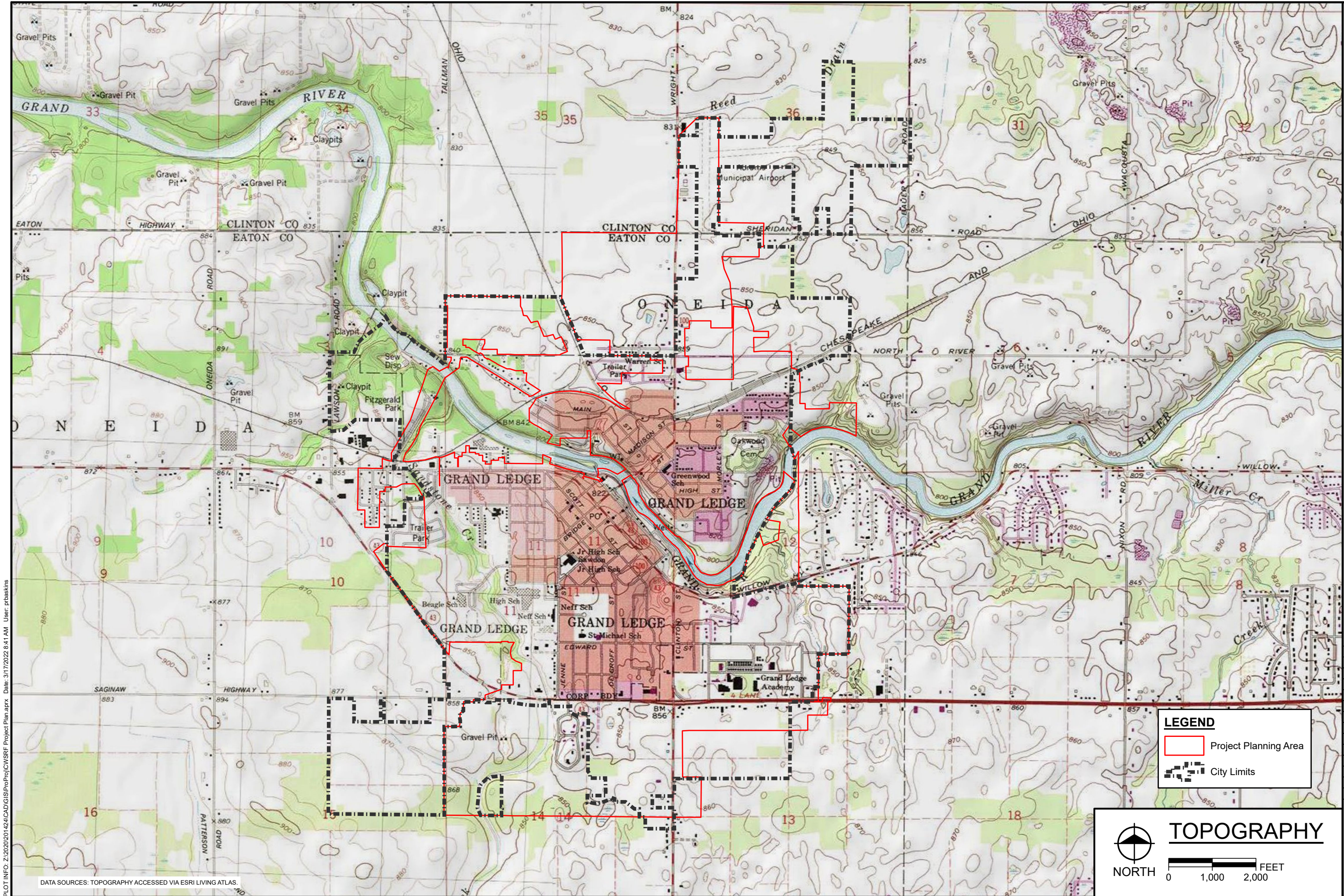

PLOT INFO: Z:\2020\201424\CAD\CIS\Proj\CWSRF Project Plan.aprx Date: 3/17/2022 8:41 AM User: prbaskins  
 ©Copyright 2022 All Rights Reserved

DATA SOURCES: TOPOGRAPHY ACCESSED VIA ESRI LIVING ATLAS.

**LEGEND**

- Project Planning Area
- City Limits

**TOPOGRAPHY**

NORTH 0 1,000 2,000 FEET

Hard copy is intended to be 11"x17" when plotted. Scale(s) indicated and graphic quality may not be accurate for any other size.

PLOT INFO: Z:\2020\201424\CAD\GIS\Proj\CWSRF Project Plan.aprx Date: 3/17/2022 8:41 AM User: pbaskins

DATA SOURCES: GEOLOGY DATA ACCESSED THROUGH STATE OF MICHIGAN GIS OPEN DATA PORTAL

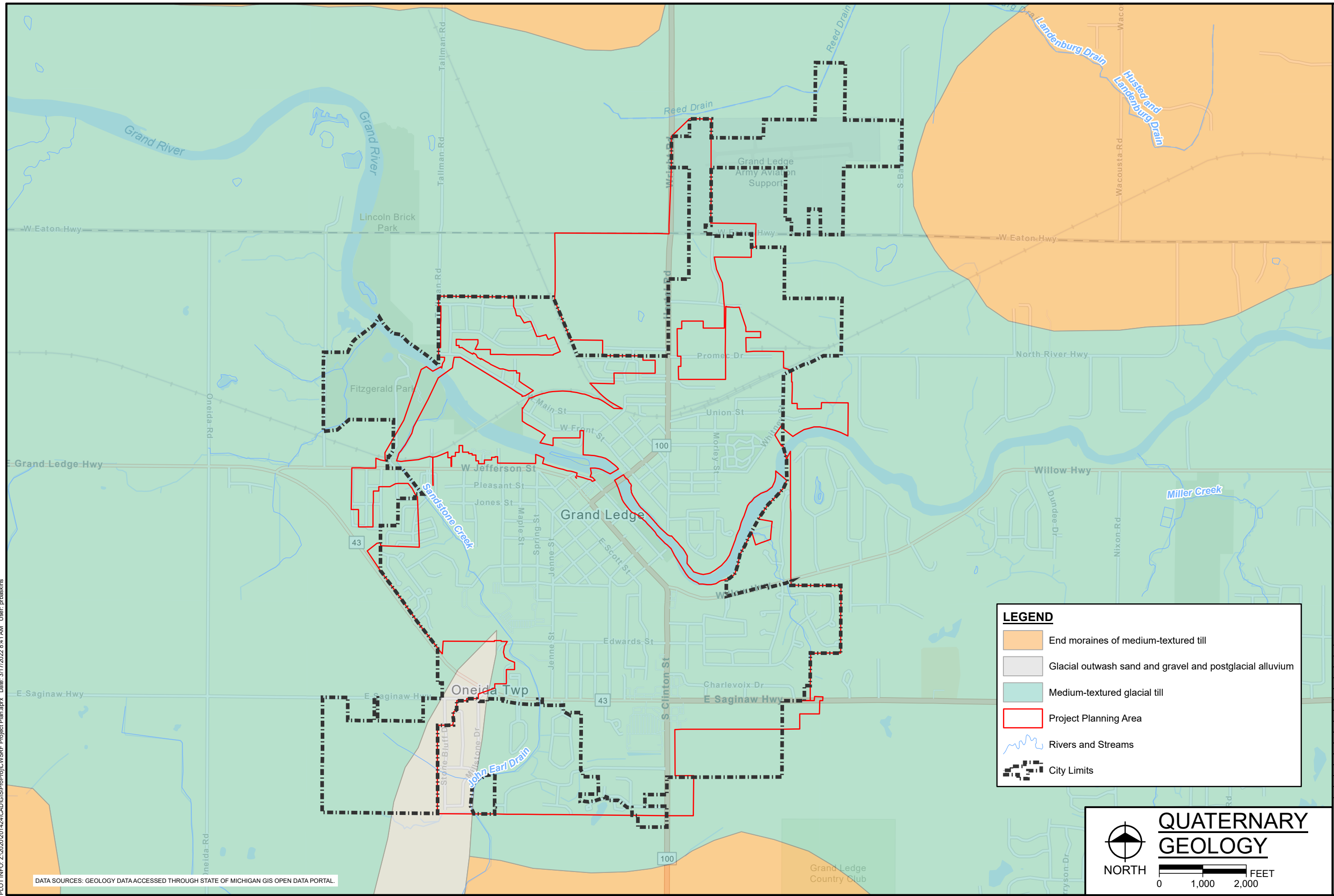

**LEGEND**

- End moraines of medium-textured till
- Glacial outwash sand and gravel and postglacial alluvium
- Medium-textured glacial till
- Project Planning Area
- Rivers and Streams
- City Limits

**QUATERNARY  
GEOLOGY**

NORTH

0 1,000 2,000 FEET

Hard copy is intended to be 11"x17" when plotted. Scale(s) indicated and graphic quality may not be accurate for any other size.

PLOT INFO: Z:\2020\201424\CAD\GIS\Proj\CWSRF Project Plan.aprx Date: 3/17/2022 8:41 AM User: pbbaskins

DATA SOURCES: USA SOILS HYDROLOGIC GROUP ACCESSED VIA ESRI LIVING ATLAS.

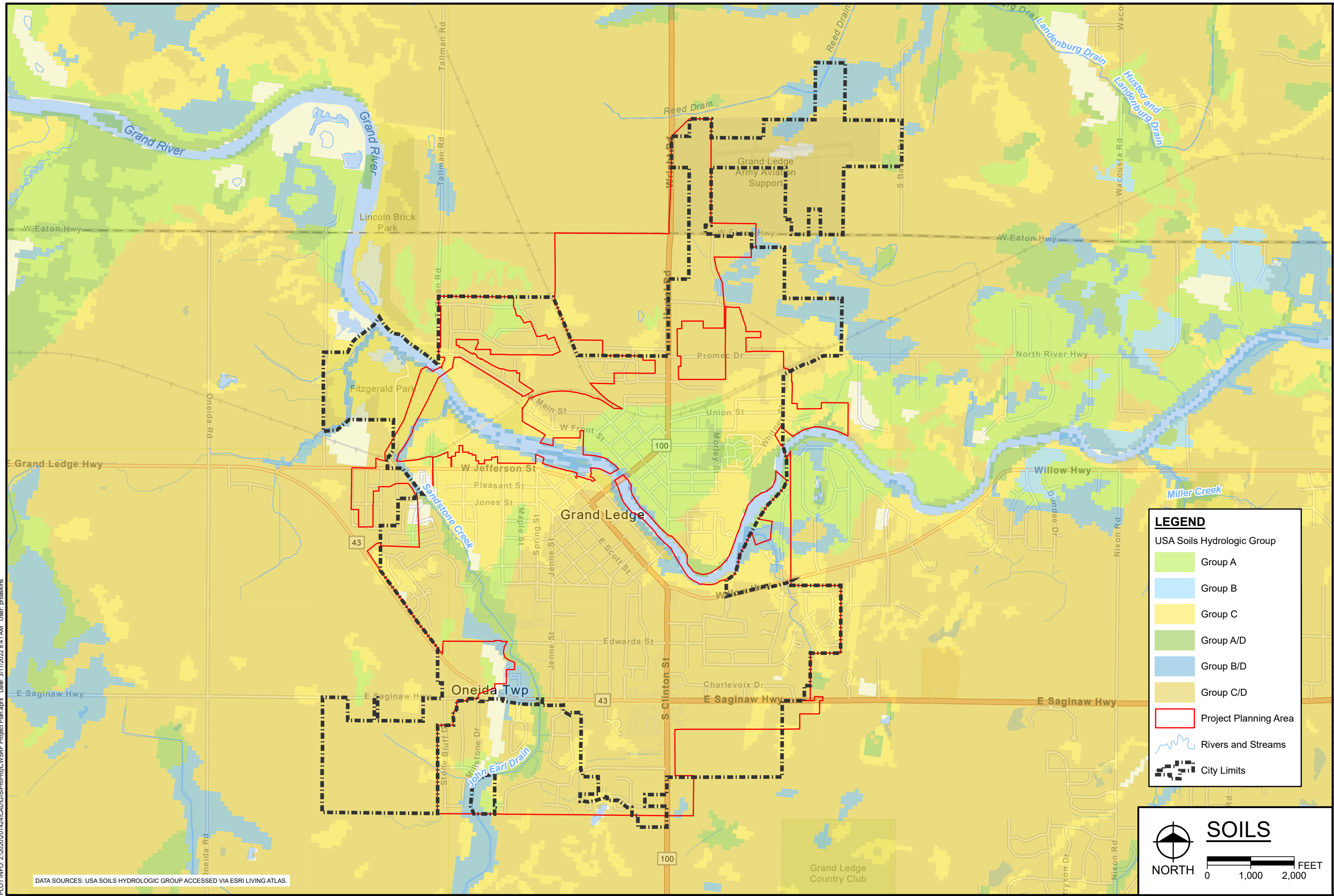

**LEGEND**

USA Soils Hydrologic Group

- Group A
- Group B
- Group C
- Group A/D
- Group B/D
- Group C/D
- Project Planning Area
- Rivers and Streams
- City Limits

**SOILS**

NORTH

0 1,000 2,000 FEET

Hard copy is intended to be 11"x17" when plotted. Scale(s) indicated and graphic quality may not be accurate for any other size.

PLOT INFO: Z:\2020\201424\CAD\GIS\Proj\CWSRF Project Plan.aprx Date: 3/17/2022 8:41 AM User: pbaskins

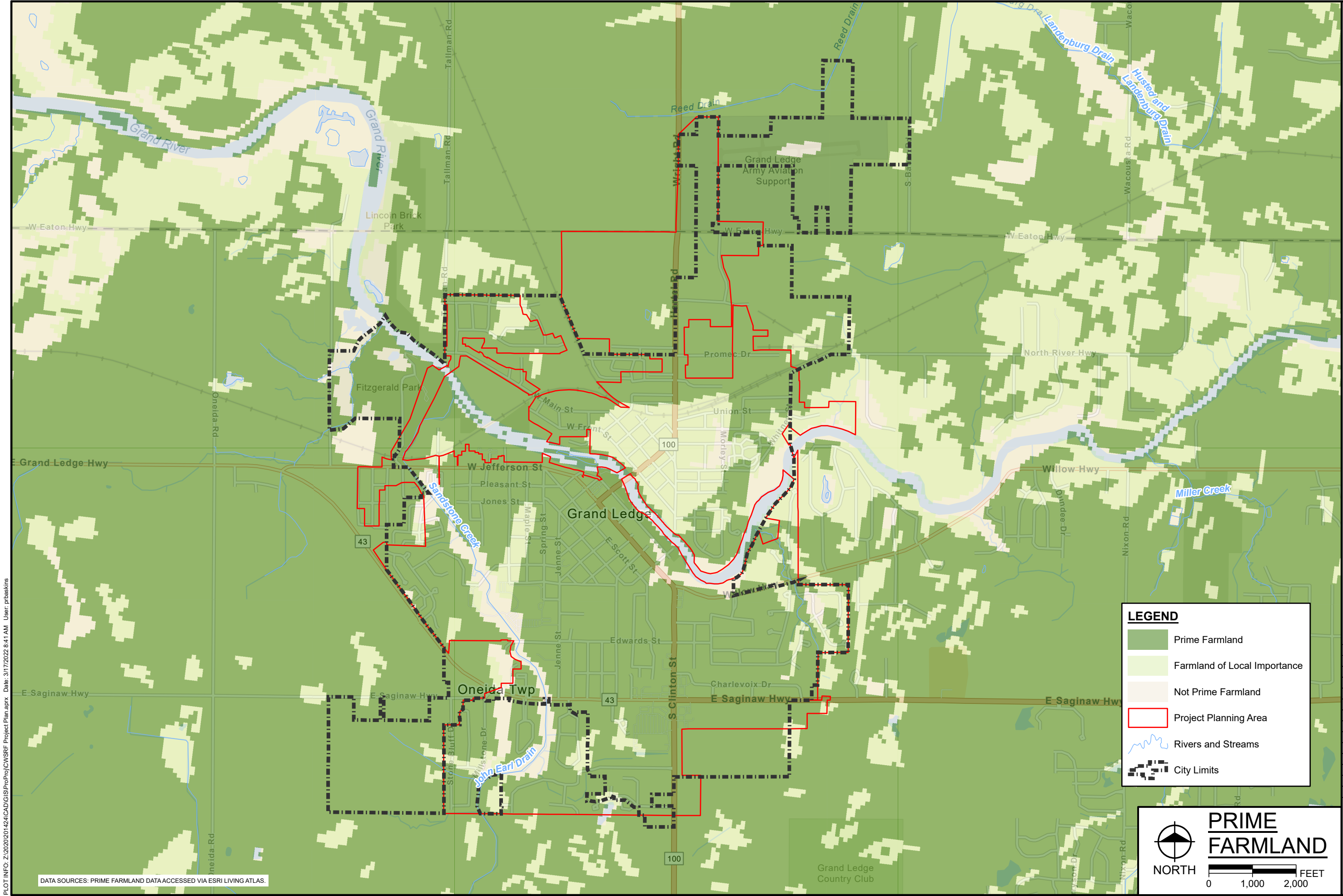

DATA SOURCES: PRIME FARMLAND DATA ACCESSED VIA ESRI LIVING ATLAS.

**LEGEND**

- Prime Farmland
- Farmland of Local Importance
- Not Prime Farmland
- Project Planning Area
- Rivers and Streams
- City Limits

**PRIME FARMLAND**

NORTH

0 1,000 2,000 FEET

Hard copy is intended to be 11"x17" when plotted. Scale(s) indicated and graphic quality may not be accurate for any other size.

**City of Grand Ledge**  
Clinton County and Eaton County, Michigan  
**Clean Water State Revolving Fund (CWSRF) Project Plan**

PROJECT NO.  
201424

FIGURE NO.  
**8**

PLOT INFO: Z:\2020\201424\CAD\GIS\Proj\CWSRF Project Plan.aprx Date: 3/17/2022 8:41 AM User: pbaskins

DATA SOURCES: NATURAL FEATURES INVENTORY DATA DOWNLOADED FROM MSU EXTENSION.

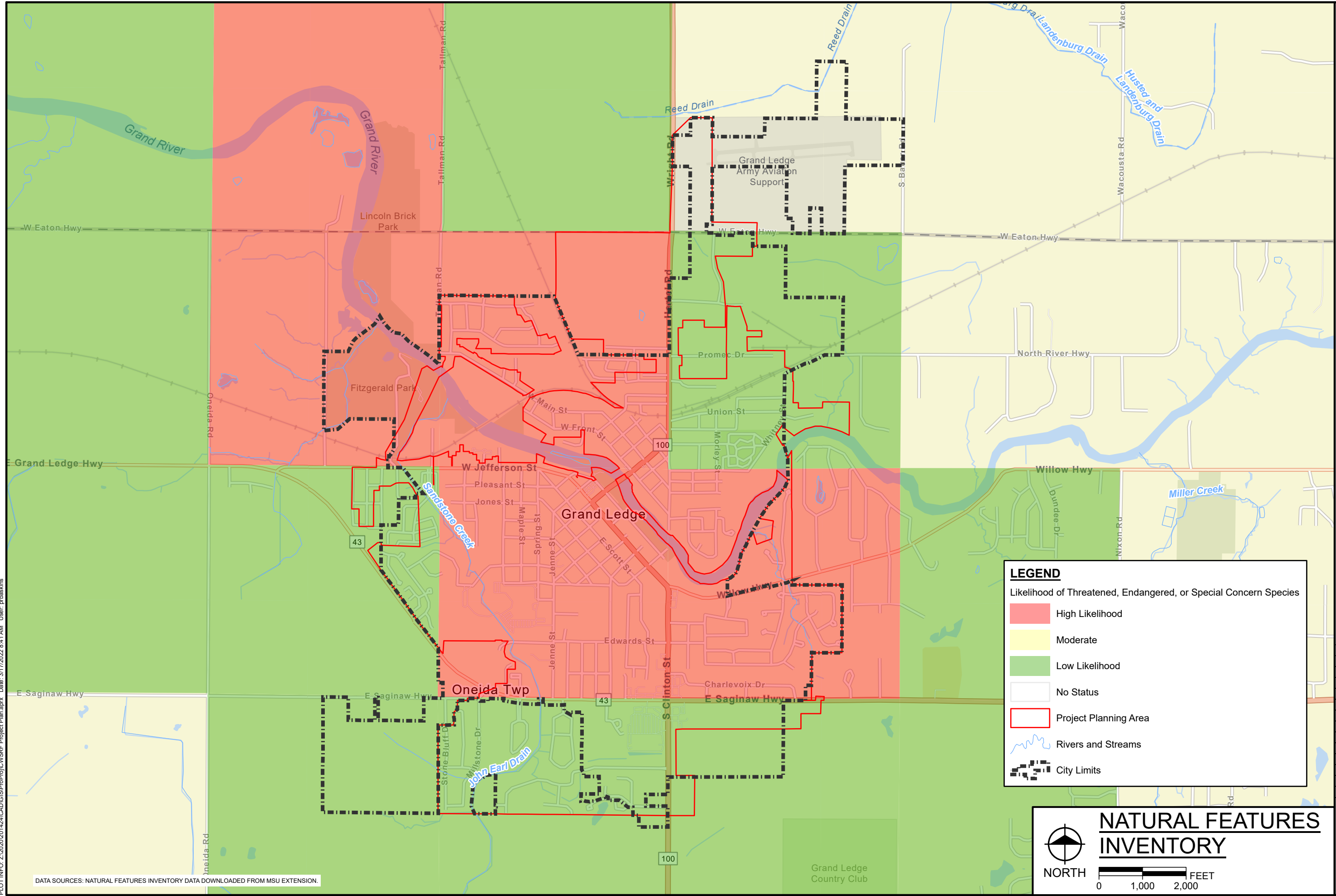

**LEGEND**  
Likelihood of Threatened, Endangered, or Special Concern Species

- High Likelihood
- Moderate
- Low Likelihood
- No Status
- Project Planning Area
- Rivers and Streams
- City Limits

**NATURAL FEATURES INVENTORY**

NORTH FEET

0 1,000 2,000

Hard copy is intended to be 11"x17" when plotted. Scale(s) indicated and graphic quality may not be accurate for any other size.

PLOT INFO: Z:\2020\201424\CAD\GIS\ProProj\CWSRF Project Plan.aprx Date: 3/17/2022 8:41 AM User: pbaskins

DATA SOURCES: EXISTING LAND USE MAP ACQUIRED FROM 2018 CITY OF GRAND LEDGE MASTER PLAN. BASE MAP AND PARCELS, EATON COUNTY 2006.

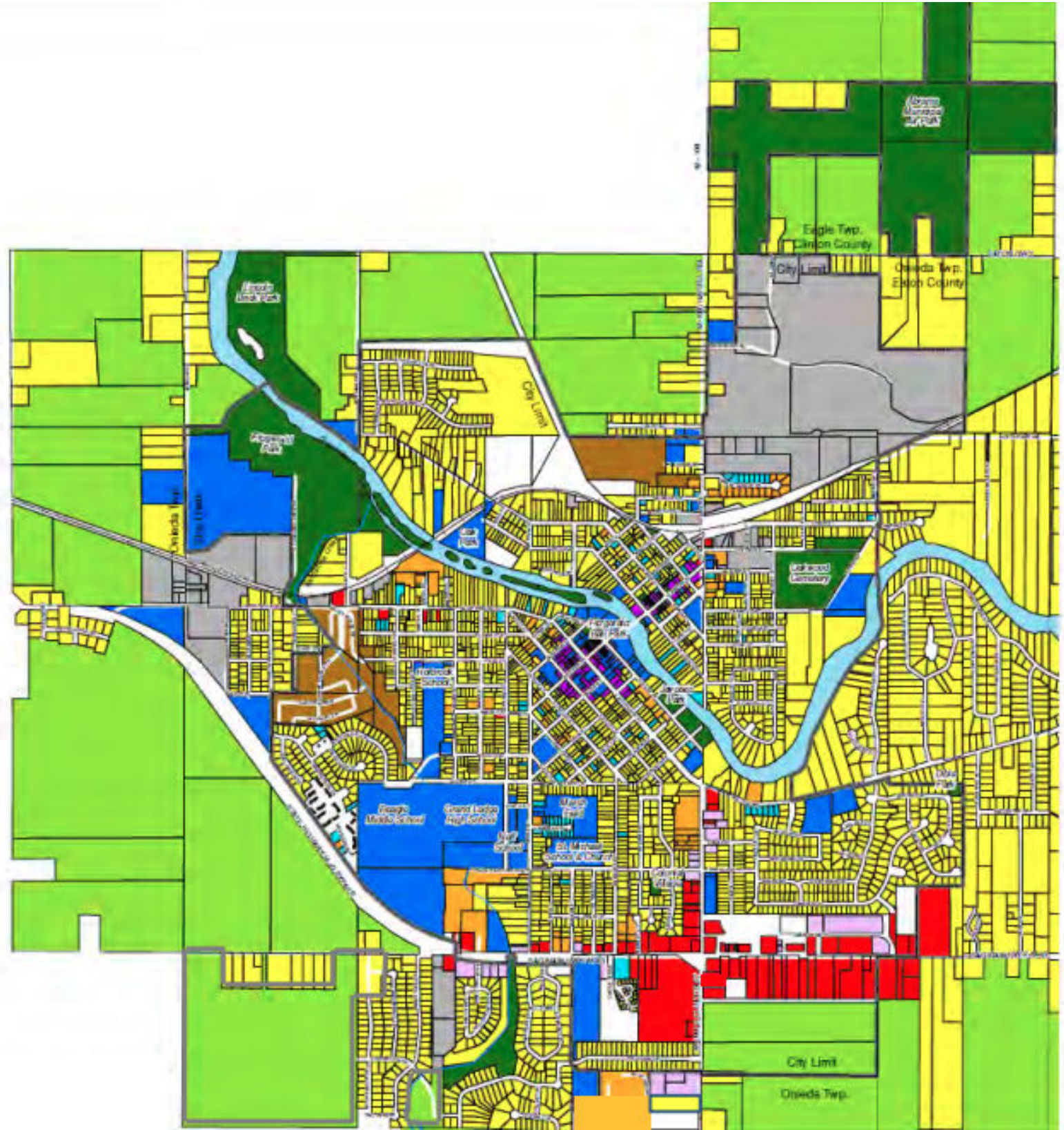

**Legend**

- Single Family Residential
- 2-Family Residential
- Multiple Family Residential 3+ Units
- Mobile Home Community
- Central Business District
- Commercial/Highway Services
- Office
- Industrial
- Churches, Schools, Public Facilities
- City and County Parks, Public Open Space/Airport, Cemeteries
- Agricultural
- Vacant



**EXISTING LAND USE**  
**JANUARY, 2018**

PROJECT NO.  
201424

FIGURE NO.  
**10**

**City of Grand Ledge**  
 Clinton County and Eaton County, Michigan  
**Clean Water State Revolving Fund (CWSRF) Project Plan**



Hard copy is intended to be 11"x17" when plotted. Scale(s) indicated and graphic quality may not be accurate for any other size.

DATA SOURCES: PLANNED LAND USE MAP ACQUIRED FROM 2018 CITY OF GRAND LEDGE MASTER PLAN. BASE MAP AND PARCELS, EATON COUNTY 2006.

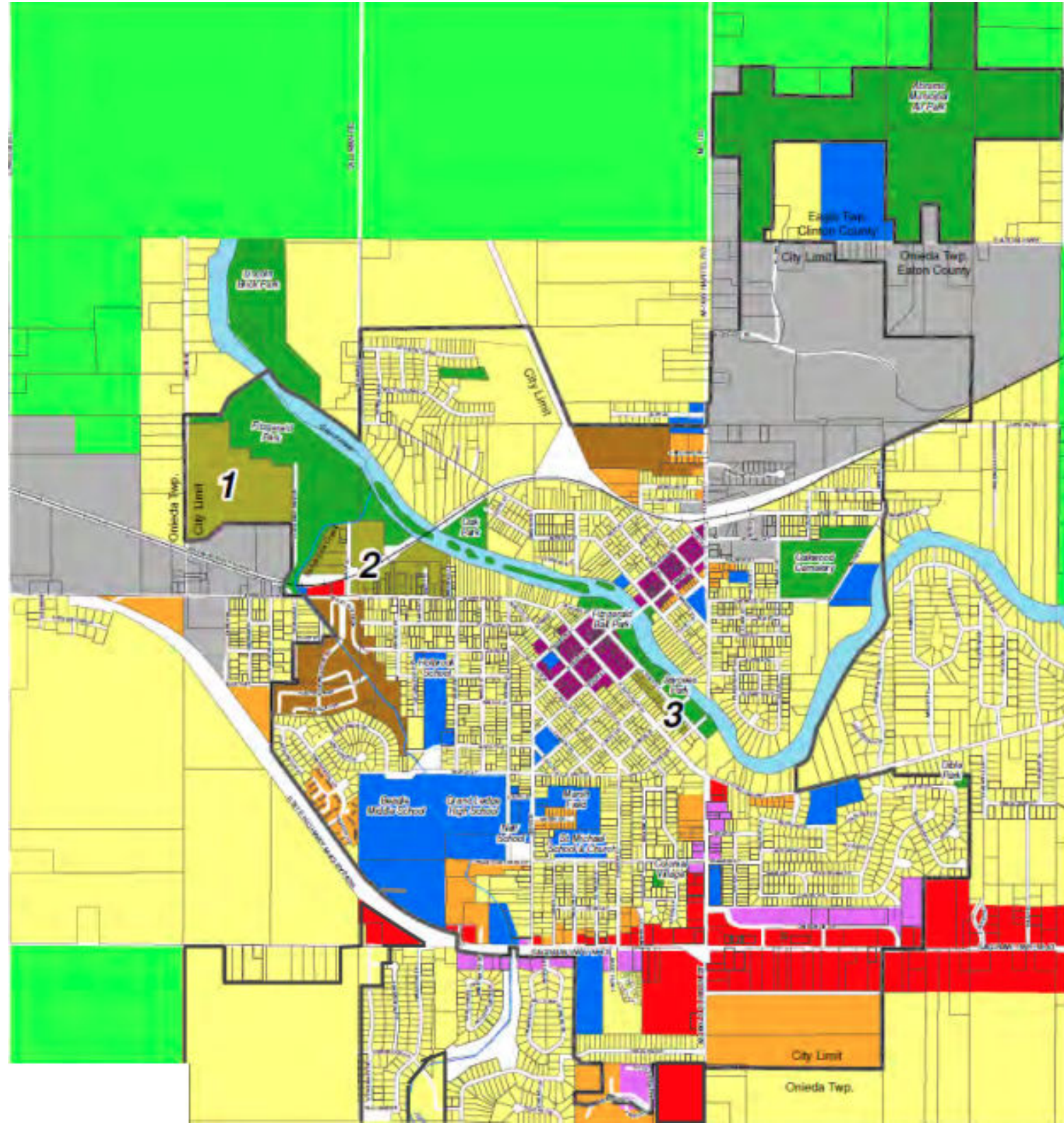

**Legend**

- Single Family Residential
- Planned Unit Development**
- Multiple Family Residential 2+ Units
- Mobile Home Community
- Central Business District
- Commercial/Highway Services
- Office
- Industrial
- Institutional: Churches, Schools, Public Facilities
- Public Open Space/Airport, City & County Parks, Cemeteries
- Agricultural



**PLANNED LAND USE**  
**JANUARY, 2018**

PROJECT NO.  
201424

FIGURE NO.  
**11**

**City of Grand Ledge**  
 Clinton County and Eaton County, Michigan

**Clean Water State Revolving Fund (CWSRF) Project Plan**



Hard copy is intended to be 11"x17" when plotted. Scale(s) indicated and graphic quality may not be accurate for any other size.

Figure 12 - WWTP Process Unit Capacity Schematic

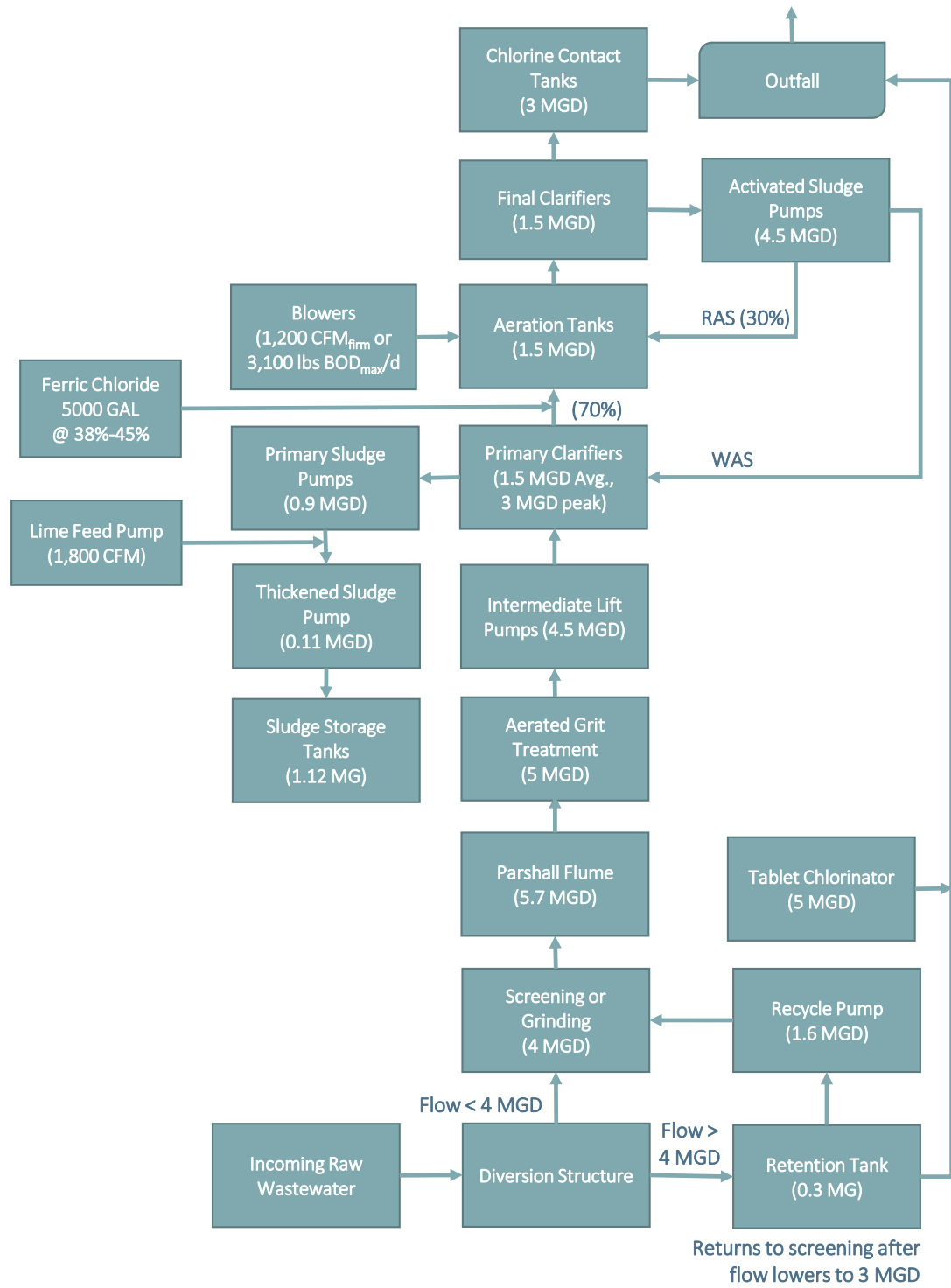

PLOT INFO: Z:\2020\201424\CAD\FIGURES\SRF PROJECT PLAN SITE PLAN FIGURES.DWG LAYOUT: FIG13-ALTERNATIVE 2 DATE: 3/23/2022 TIME: 1:37:52 PM USER: JREDNER

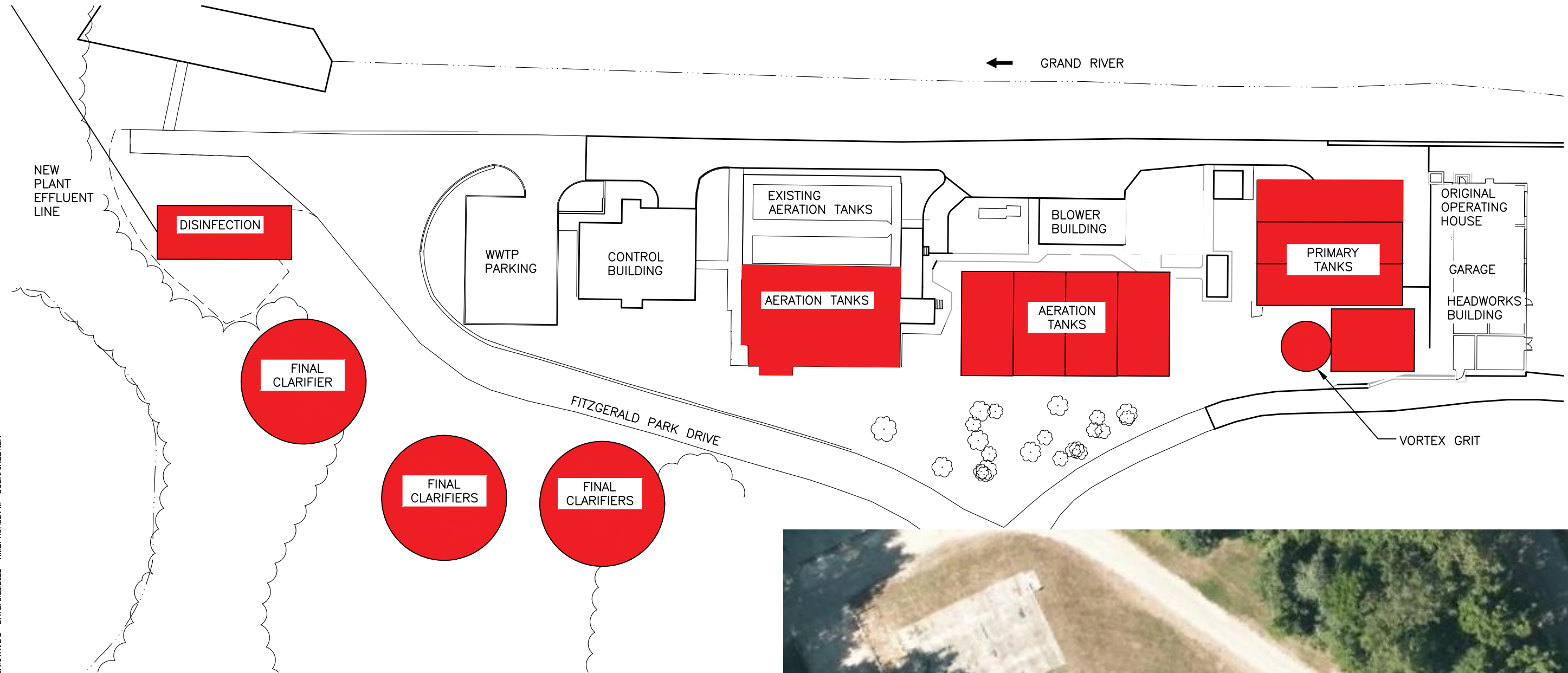

**ALTERNATIVE 2 SITE MAP**

SCALE: 1" = 50'

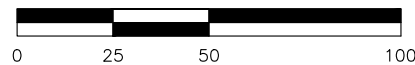

**LEGEND**

	EDGE OF WATER		LIGHT		GRAVEL SURFACE
	SHRUBS		GUY ANCHOR		PAVED SURFACE
	DECIDUOUS TREE		UTILITY POLE		CURB & GUTTER
	HEDGE EDGE OF WOODS		SIGN		FENCE



**SOLIDS STORAGE AREA**

SCALE: 1" = 50'

← GRAND RIVER

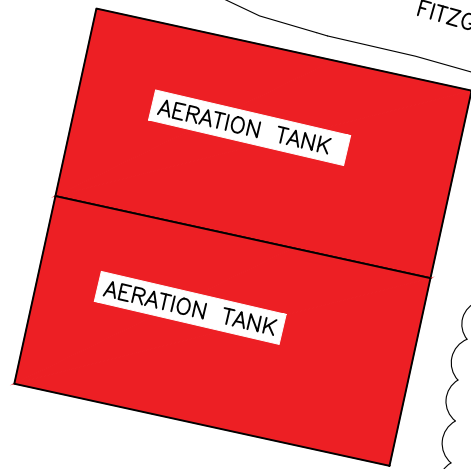
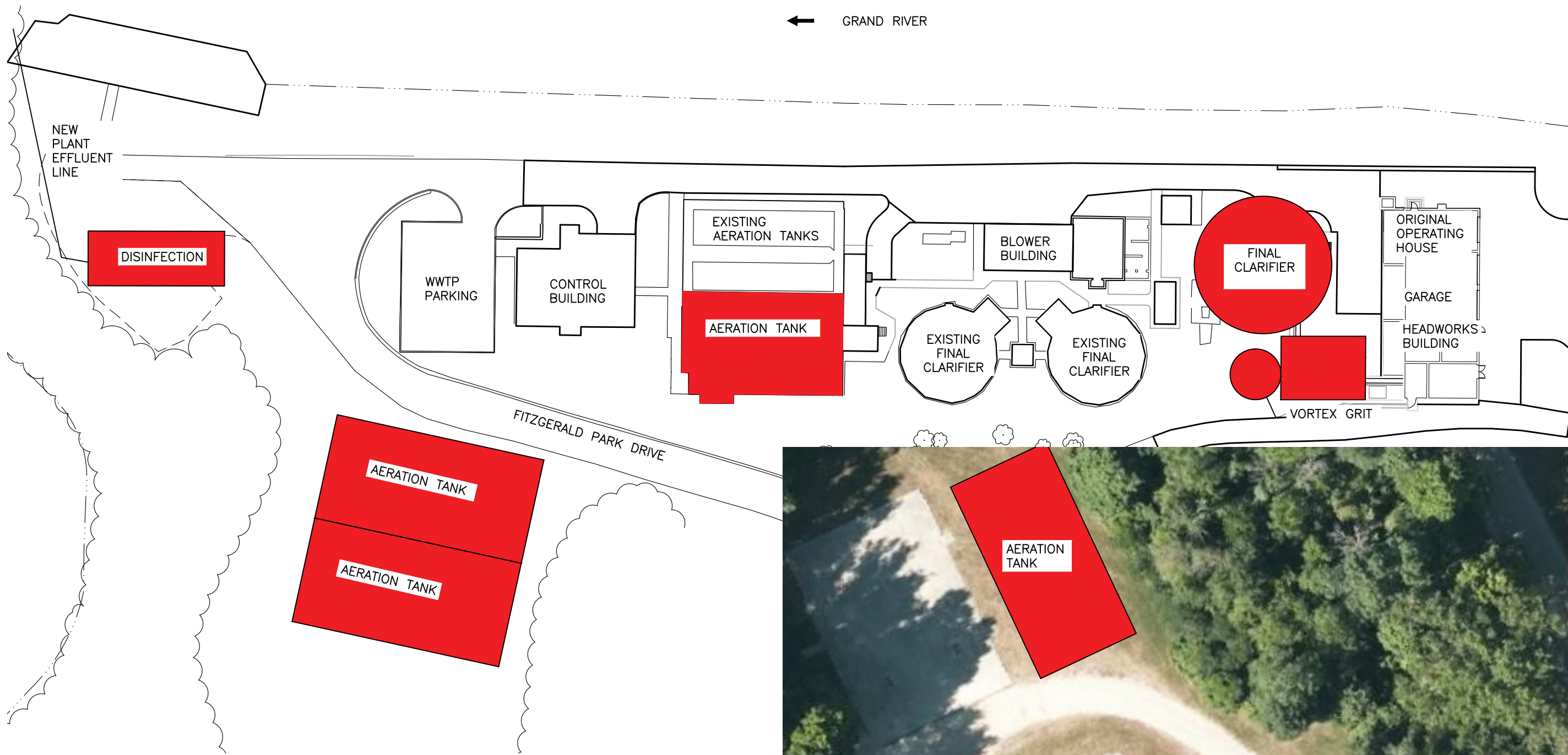

**SOLIDS STORAGE AREA**

SCALE: 1" = 50'

PLOT INFO: Z:\2020\201424\CAD\FIGURES\SRF PROJECT PLAN SITE PLAN FIGURES.DWG LAYOUT: FIG14-ALTERNATIVE 3 DATE: 3/30/2022 TIME: 12:57:09 PM USER: JREDNER



**ALTERNATIVE 3 SITE MAP**

SCALE: 1" = 50'

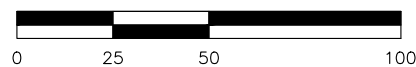

**LEGEND**

	EDGE OF WATER		LIGHT		GRAVEL SURFACE
	SHRUBS		GUY ANCHOR		PAVED SURFACE
	DECIDUOUS TREE		UTILITY POLE		CURB & GUTTER
	HEDGE EDGE OF WOODS		SIGN		FENCE

Hard copy is intended to be 11"x17" when plotted. Scale(s) indicated and graphic quality may not be accurate for any other size.

PLOT INFO: Z:\2020\201424\CAD\FIGURES\SRF PROJECT PLAN SITE PLAN FIGURES.DWG LAYOUT: FIG15-ALTERNATIVE 4 DATE: 3/23/2022 TIME: 1:46:03 PM USER: JREDNER

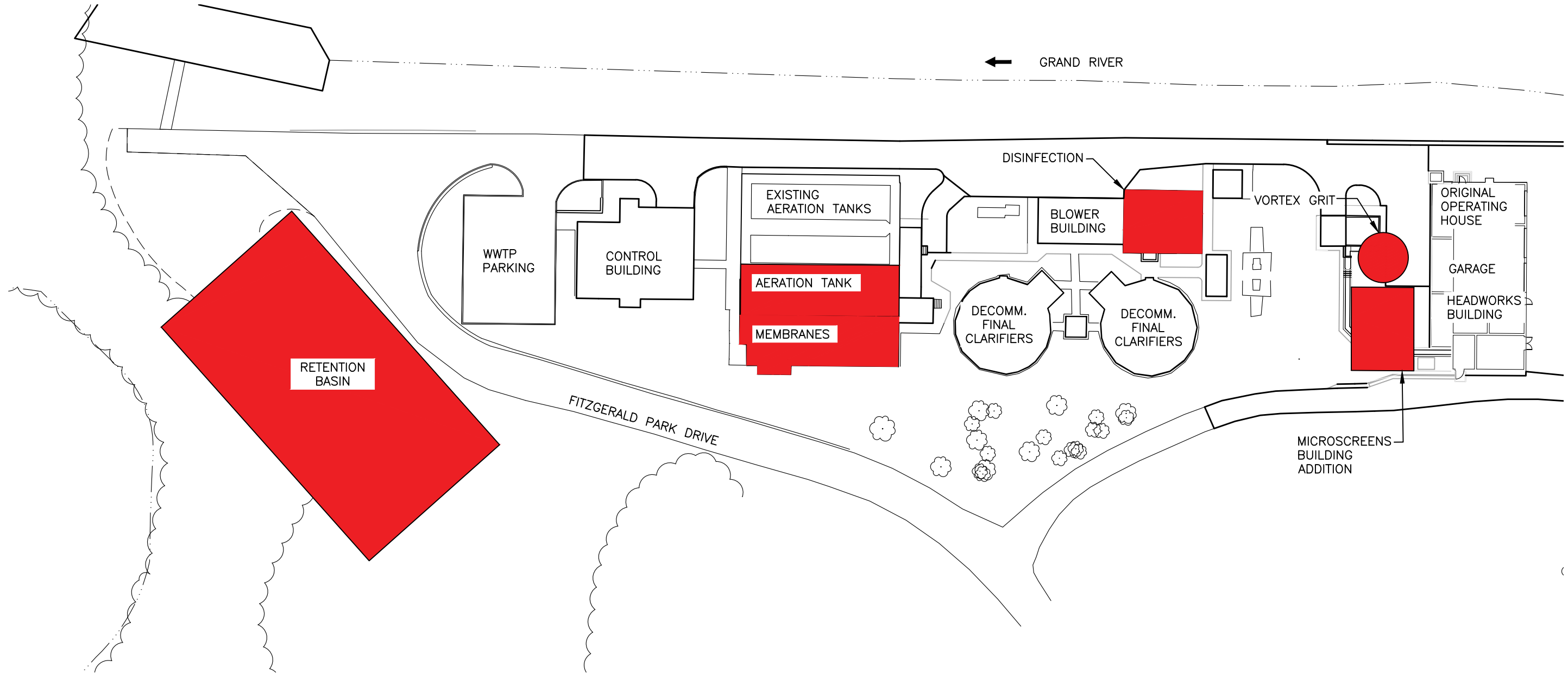

### ALTERNATIVE 4 SITE MAP

SCALE: 1" = 50'

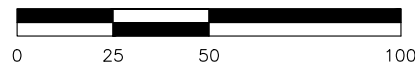

#### LEGEND

	EDGE OF WATER		LIGHT		GRAVEL SURFACE
	SHRUBS		GUY ANCHOR		PAVED SURFACE
	DECIDUOUS TREE		UTILITY POLE		CURB & GUTTER
	HEDGE EDGE OF WOODS		SIGN		FENCE

PLOT INFO: Z:\2020\201424\CAD\GIS\PreProj\CWSRF Project Plan.aprx Date: 3/25/2022 10:09 AM User: pfbaskins

DATA SOURCES: CITY OF GRAND LEDGE, MICHIGAN

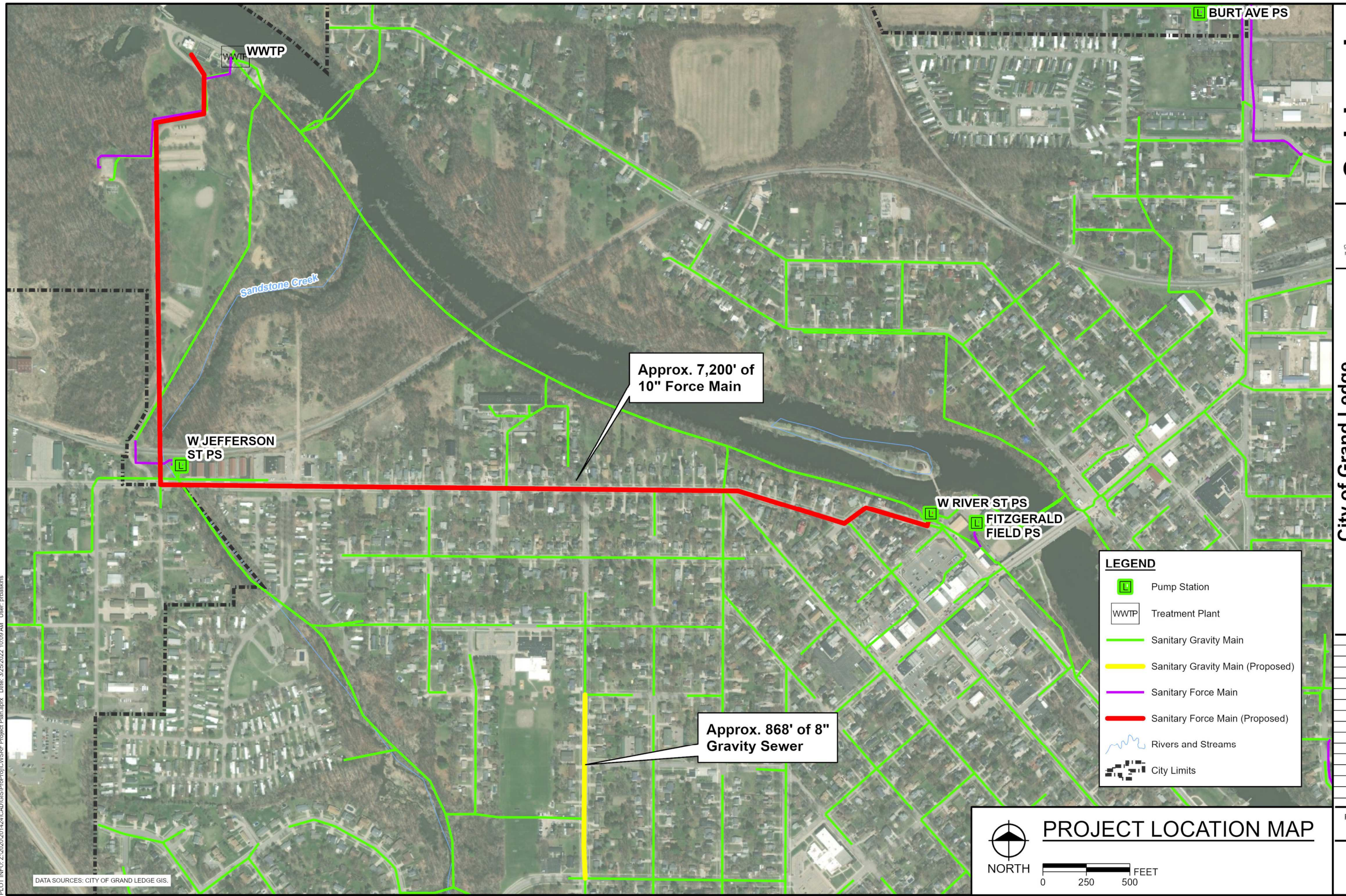

**LEGEND**

- Pump Station
- Treatment Plant
- Sanitary Gravity Main
- Sanitary Gravity Main (Proposed)
- Sanitary Force Main
- Sanitary Force Main (Proposed)
- Rivers and Streams
- City Limits

**PROJECT LOCATION MAP**

NORTH

0 250 500 FEET

Hard copy is intended to be 11"x17" when plotted. Scale(s) indicated and graphic quality may not be accurate for any other size.

# Appendix 1

---

RECEIVED

JUL 23 1987

United States Department of the Interior  
National Park Service

NATIONAL  
REGISTER

National Register of Historic Places  
Registration Form

This form is for use in nominating or requesting determinations of eligibility for individual properties or districts. See instructions in *Guidelines for Completing National Register Forms* (National Register Bulletin 16). Complete each item by marking "x" in the appropriate box or by entering the requested information. If an item does not apply to the property being documented, enter "N/A" for "not applicable." For functions, styles, materials, and areas of significance, enter only the categories and subcategories listed in the instructions. For additional space use continuation sheets (Form 10-900a). Type all entries.

1. Name of Property

historic name Grand Ledge Chair Company Plant  
other names/site number \_\_\_\_\_

2. Location

street & number 101 Perry Street N/A not for publication  
city, town Grand Ledge N/A vicinity  
state Michigan code MI county Eaton code 045 zip code 48837

3. Classification

Ownership of Property	Category of Property	Number of Resources within Property	
<input checked="" type="checkbox"/> private	<input type="checkbox"/> building(s)	Contributing	Noncontributing
<input type="checkbox"/> public-local	<input checked="" type="checkbox"/> district	<u>2</u>	<u>1</u> buildings
<input type="checkbox"/> public-State	<input type="checkbox"/> site	<u>0</u>	<u>0</u> sites
<input type="checkbox"/> public-Federal	<input type="checkbox"/> structure	<u>2</u>	<u>2</u> structures
	<input type="checkbox"/> object	<u>0</u>	<u>0</u> objects
		<u>4</u>	<u>3</u> Total

Name of related multiple property listing: N/A

Number of contributing resources previously listed in the National Register 0

4. State/Federal Agency Certification

As the designated authority under the National Historic Preservation Act of 1966, as amended, I hereby certify that this  nomination  request for determination of eligibility meets the documentation standards for registering properties in the National Register of Historic Places and meets the procedural and professional requirements set forth in 36 CFR Part 60. In my opinion, the property  meets  does not meet the National Register criteria.  See continuation sheet.

[Signature] 7-21-87  
Signature of certifying official Date  
Director, Bureau of History Admnty SHPO  
State or Federal agency and bureau

In my opinion, the property  meets  does not meet the National Register criteria.  See continuation sheet.

\_\_\_\_\_  
Signature of commenting or other official Date  
\_\_\_\_\_  
State or Federal agency and bureau

5. National Park Service Certification

I, hereby, certify that this property is:

entered in the National Register.  
 See continuation sheet.

determined eligible for the National Register.  See continuation sheet.

determined not eligible for the National Register.

removed from the National Register.

other, (explain:) \_\_\_\_\_

\_\_\_\_\_  
Signature of the Keeper

\_\_\_\_\_  
Date of Action

## 6. Function or Use

Historic Functions (enter categories from instructions)

Industry/Processing/Extraction  
manufacturing facility

Current Functions (enter categories from instructions)

Vacant/Not in Use

## 7. Description

Architectural Classification  
(enter categories from instructions)

No Style

Materials (enter categories from instructions)

foundation Stone

walls Brick

wood/weatherboard

roof Asphalt

other

Describe present and historic physical appearance.

The Grand Ledge Chair Company Plant is located near the western edge of the city of Grand Ledge. It occupies a seven-acre site on level ground atop a wooded bluff overlooking the Grand River. A Pere Marquette Railroad line forms the northwest border of the complex and crosses the Grand River directly adjacent to the plant's river frontage. The plant contains three buildings, two of which contribute to its historic character, and four structures, two of which are contributing. The principal building, which terminates the view along the short street providing access to the site, is a long and narrow, three-story, brick factory building built in 1906. The site also contains a small, frame factory building, brick power house, and veneer storage shed built of clay tile.

The factory complex is located at the end of Perry Street, a short, minor street containing several modest, turn-of-the-century, frame houses. The 1906 factory stands at the end of the street and is highly visible from the West Jefferson Street intersection, the ornamental central part of the facade, crowned by a water tower, being positioned directly in line with Perry Street. The grounds in front of the 1906 building to the right of Perry Street and behind the 1906 building back to the river bluff are level lawn areas containing a scattering of old deciduous trees. Some parts of the grounds have become somewhat overgrown in the years since furniture-manufacturing ceased.

The 1906 factory building (contributing) is 353.5 feet long by fifty feet wide and is three stories in height and built of cream-color brick with red brick accents. This structure, which housed the assembly, finishing, and shipping processes of the chair company, exemplifies heavy, timber, mill construction typical of the turn-of-the-century period. The building has a flat, built-up roof. Except for enclosed staircases, the building interior on each floor is largely a single open space with exposed plank flooring above floor joists for a ceiling and chamfered-edge vertical posts. The building's facade has a regular fenestration of double-hung windows set into segmental-arch heads. The portion of the facade fronting on Perry Street is treated in a somewhat more ornamental fashion, with a stepped-gable design containing in its center the main entrance and tripartite windows in the second and third stories above it. The parapets have corbelled brick detailing below the cornice line. Perched atop the roof on a square, brick base and in line with the main entrance is a wood-slat water tank held together with steel bands. Water penetration since the closing of the furniture operation has caused considerable damage to framing members as well as brickwork in parts of the building.

Immediately to the west of the 1906 building is a low, steel-frame, sheet-steel-sided warehouse structure (non-contributing) constructed in 1957-58. Used originally for cutting, shaping, and assembly operations, this replaced the original three-story, frame factory building at this site.

To the north of the 1957-58 structure is a thirty-two by one hundred twelve-foot, one-story, frame building that was part of the original factory building (contributing). Part of this building has collapsed and the remainder is ruinous.

See continuation sheet

7/23/87

United States Department of the Interior  
National Park Service

**National Register of Historic Places  
Continuation Sheet**

Section number 7 Page 2

---

West of the 1957-58 structure and the frame factory building are the foundation remains and rubble from a bending room, engineering room and storage, and drying kiln demolished several years ago.

North of the frame factory building remnant is a red brick boiler house structure (contributing) which dates from 1902. This flat-roof, steel-frame structure was enlarged at some undetermined time after the original construction to contain an additional boiler. The structure adjoined a railroad siding and the steel-frame canopy covering the siding survives on the structure's north side. The boiler house is severely deteriorated.

The final contributing structure on the grounds is a one-story, twenty by fifty-three-foot, clay tile veneer storage shed. This gable-roof structure has settled unevenly and one part of a wall has collapsed.

The property also contains a one-story, modern, brick house (non-contributing building) and garage behind it (non-contributing structure). These are located on the east side of Perry Street in front of the 1906 factory building. On the west side of Perry Street in front of the 1906 building is a parking lot.

At one time, smaller structures existed on the site, including an oil house and storage structure near the center of the property, a storage and glue structure north of the original wood factory and east of the boiler house, and a stock shed and storage structure in the southwest corner of the site. Railroad sidings penetrated the site near the boiler house, the kiln, and along the north side of the brick factory. Only minor above ground remains of these improvements exist.

Rehabilitation of this property for apartment use is now under way and will likely result in the demolition of all buildings and structures on the property except for the 1906 factory and the modern house and garage standing in front.

## 8. Statement of Significance

Certifying official has considered the significance of this property in relation to other properties:

nationally  statewide  locally

Applicable National Register Criteria  A  B  C  D

Criteria Considerations (Exceptions)  A  B  C  D  E  F  G

Areas of Significance (enter categories from instructions)

Architecture  
Engineering  
Industry

Period of Significance

1902-1906  
1906  
1902-1930s

Significant Dates

N/A  
N/A  
1902-1906

Cultural Affiliation

N/A

Significant Person

Edward Turnbull

Architect/Builder

Unknown

State significance of property, and justify criteria, criteria considerations, and areas and periods of significance noted above.

The Grand Ledge Chair Company Plant is the only example surviving in the Grand Ledge-Lansing area of a furniture-manufacturing complex built during the heyday of the furniture-manufacturing industry in southern Michigan in the late nineteenth and early twentieth centuries. It housed one of Grand Ledge's principal industrial concerns and largest employers in the early twentieth century. The 1906, brick factory building is the best preserved and least altered example of turn-of-the-century factory design in the Grand Ledge-Lansing area and exemplifies the use of fire-resistant mill construction techniques characteristic of Michigan factory design of the period.

Furniture manufacturing flourished in southern Michigan in the late nineteenth and early twentieth centuries, because of the availability of high quality wood from the deciduous forests of the central and northern Lower Peninsula and the development of railroad lines which facilitated the shipping of raw materials as well as finished products. The reputation for fine quality furniture which Grand Rapids had achieved in the wake of its furniture manufacturers' popular displays at the 1876 Centennial Exposition perhaps also had a spin-off effect. The result was that plants manufacturing furniture for the home, school, church, lodge hall, and other commercial and institutional uses were established in many smaller southern Michigan towns — such as Sturgis, Allegan, Hastings, Ionia, Northville, and Ann Arbor — beginning in the 1880s and down to the 1920s. The Grand Ledge Chair Company fits into the general pattern.

The Grand Ledge Chair Company originated in 1874 as a small furniture shop located near the corner of Bridge and River Streets in the center of Grand Ledge. The original firm, variously called the Grand Ledge or Michigan Chair Company, was reorganized and incorporated December 1, 1888 as the Grand Ledge Chair Company by the three original owners, Thomas Garrett, Harry Jordan, and Edward Crawford of Grand Rapids. The three sold out in 1893 to Edward H. Turnbull and George W. Fletcher. Turnbull soon bought out Fletcher's interests.

Under the management of Turnbull, who lived nearby on West Jefferson Street, the company prospered. In 1902, Turnbull, along with relatives David Bell and George Coryell, founded the Grand Ledge Table Company and constructed a three-story factory, a power house, and a one-story mill building on the newly acquired Perry Street site. The company intended to manufacture living room tables, but chair orders increased to the point of requiring additional facilities, and some of the chair production was relocated to the Perry Street site. Between 1902 and 1905, Turnbull purchased both the Coryell and Bell interests. He then expanded his operations in 1906 by constructing a large three-story brick building adjacent to the existing Table Company Building and connecting them at the third floors. This new building provided the product finishing on the third floor, upholstering and storage on the second, and shipping and offices on the first floor.

See continuation sheet

7/23/87

United States Department of the Interior  
National Park ServiceNational Register of Historic Places  
Continuation SheetSection number 8 Page 2

Edward Turnbull died in 1916, leaving the chair company to his wife, Emma A. Turnbull. Emma, along with trusted key employees, continued to manage the company through the Depression years and a 1941 unionization, until her death in 1944. At that time, the company was willed to her youngest sister, Mrs. Raymond Hull, who, along with her husband Raymond, managed the company through a lengthy strike and incorporation in 1949. Mrs. Hull died in 1950, leaving the company to her family. The firm was managed by her husband until 1966 and for the next seven years by Mrs. Hull's grandsons. In December 1973 the company became the Grand Ledge Chair Company, Division of Holabird Company, a manufacturing holding company. Finally, due to falling sales, the factory was permanently closed in the fall of 1981.

One of the most significant historical impacts of this company is its employment over the years of the company's existence. The population of Grand Ledge grew from 1,378 in 1890 to about 3,000 in 1910. This same period saw the development of the chair factory, along with a brick works and two sewer/conduit pipe plants, as the principal industries in town. Although accurate accounts are difficult to obtain, an 1884 account listed "17 hands employed" at the Chair Company. A later report in the Detroit Free Press in 1901 noted 100 employees. In early 1906, the Grand Ledge Independent reported that the business employed 225 men the full year with a payroll of \$8,000 per month and, with the completion of the new brick building, Mr. Turnbull was predicting employing an additional 400 men. However, in a November 13, 1926 article in the Lansing State Journal, only 200 employees were reported. In 1936, 130 men and women were employed with a payroll at the peak of 15,000 every two weeks. Another State Journal report on November 23, 1941 (the year of unionization) claimed 250 were employed. In 1948, there were 116 employees and "many home workers," mostly women weavers creating cattail chair seats and backs. By August 2, 1964 the work force had dwindled to 70 workers.

Research into the Annual Reports of the State Bureau of Labor noted the employment of 113 men and 2 women in 1902, 158 men and 6 women in 1906, 110 men and 3 women in 1912, 77 men and 7 women in 1915 and 110 men and 26 women in 1920, the last of the Annual Reports.

In summary it appears that the optimistic 1906 report by Mr. Turnbull of being able to employ 600 men and women was a bit of "chest thumping." However, it is very apparent the factory was the largest employer for many years in the Grand Ledge community. There was hardly a family in the area that didn't have at least one member as a Chair Factory employee.

A second significant historical impact of the company is the product that was produced. The company, though with very small beginnings in a carpenter shop, soon received substantial acclaim for the quality and design of the chair produced. Even in 1934, an account in the local newspaper identified the Grand Ledge Chair Company product as being distributed world wide. The company sold primarily to the quantity buyer or large contract sales. Locals could, however, purchase a variety of the chairs in the Tucker Department Store. Meanwhile, entire shipments of chairs were arriving at institutions such as Michigan State University, University of Michigan, Indiana University, and others. The chairs also graced the parlours of hotels, embassies, corporate offices and similar businesses. Perhaps the company's greatest glory and national recognition came when 2,800 chairs were chosen to furnish the Library of Congress and the Rayburn Office Building in Washington, D.C. in 1964. Today many of the remaining chairs grace homes and museums as collectors pieces, remnants of an era of fine woods, craftsmanship, and elegant design.

7/23/07

United States Department of the Interior  
National Park Service

## National Register of Historic Places Continuation Sheet

Section number 8 Page 3

---

The Chair Company's three-story, brick, factory building is today unique in the Grand Ledge-Lansing area as a little altered example of turn-of-the-century factory design constructed with a timber framing system. The building's design exemplifies the standard "mill construction" of the period that was designed to be fire resistant and to reduce fire damage to a minimum. The ideal, fire-resistant factory building of the period had masonry exterior walls to discourage the entrance into the building of a fire originating outside and a heavy timber frame substantial enough that it would continue to provide support even if the timbers were reduced in section dimensions through burning or the floors had unusually heavy loading from water poured on the fire. Finally, the interior was designed with the framing and flooring fully exposed to view and without crawl spaces or hollow partitions. This made fighting any fire which did break out much simpler. The Grand Ledge Chair Company 1906 building seems to exemplify all these design innovations, which were coming into common use in Michigan only in the 1890s.

**9. Major Bibliographical References**

Previous documentation on file (NPS): N/A

- preliminary determination of individual listing (36 CFR 67) has been requested
- previously listed in the National Register
- previously determined eligible by the National Register
- designated a National Historic Landmark
- recorded by Historic American Buildings Survey # \_\_\_\_\_
- recorded by Historic American Engineering Record # \_\_\_\_\_

See continuation sheet

Primary location of additional data:

- State historic preservation office
- Other State agency
- Federal agency
- Local government
- University
- Other

Specify repository:

Grand Ledge Library

**10. Geographical Data**

Acreeage of property About seven acres

UTM References

A 

16	18	3	64	0	4	7	36	0	50
----	----	---	----	---	---	---	----	---	----

  
Zone Easting Northing

B 

--	--	--	--	--	--	--	--	--	--

  
Zone Easting Northing

C 

--	--	--	--	--	--	--	--	--	--

D 

--	--	--	--	--	--	--	--	--	--

See continuation sheet

Verbal Boundary Description

See continuation sheet

Boundary Justification

This tract includes the entire site associated with the Chair Company plant.

See continuation sheet

**11. Form Prepared By**

name/title Les Linsemier/R. O. Christensen

organization Linsemier and Associates

street & number 422 W. Lenawee

city or town Lansing

date 6-1987

telephone 517/372-1372

state MI

zip code 48933

7/23/07

United States Department of the Interior  
National Park Service

National Register of Historic Places  
Continuation Sheet

Section number 9 Page 2

Bibliographic References

Abstract of Title, Sec. 2, T4N, R4W, Eaton County.

Annual Report, Michigan Bureau of Labor, 19th thru 37th Annual Reports.

"Fine Furniture Still A Grand Ledge Trademark," The Independent, Sept. 11, 1974.

"Firm Saluted in Michigan Week," The Independent, May 25, 1978.

"Grand Ledge," Lansing State Journal, Nov. 13, 1926.

Grand Ledge Area Historical Society, 1984. Greetings from Grand Ledge. Grand Ledge, Michigan.

Grand Ledge Area American Revolution Bicentennial Commission, 1978. The Nature of Grand Ledge. Grand Ledge, Michigan.

"Grand Ledge Chair Company Carries on Areas Long Furniture Tradition," The Independent, May 13, 1976.

"Grand Ledge Chair Company Is Celebrating Its Golden Anniversary," The Independent, May 11, 1934.

Grand Ledge Historical Society, 1976. Grand Ledge Remembered. Grand Ledge, Michigan.

Michigan Historical Commission, The Past and Present of Eaton County, Chapter XVIII, Banks and Manufacturers, page 127, no published date, but around 1905.

"Know Your Michigan...Grand Ledge," Lansing State Journal, Nov. 23, 1941.

Lansing's Neighbor...Grand Ledge," Lansing State Journal, August 2, 1964.

Odenkirk, Thomas, 1959. History & Geography of Grand Ledge. A thesis presented to Michigan State University, East Lansing, Michigan.

Pierce, Grace Porter, 1936. History of Grand Ledge. Souvenir program of the Michigan Centenary & Historical Pageant. Grand Ledge Chamber of Commerce, Grand Ledge, Michigan. 1936 Centennial Edition.

Grand Ledge Library, 1966. Brief History of Grand Ledge Chair Company 1883-1966. Unsigned manuscript in Vertical File. Grand Ledge, Michigan.

AENR87180A AENR87180F

7/29/87

United States Department of the Interior  
National Park Service

National Register of Historic Places  
Continuation Sheet

Section number 10 Page 2

LEGAL DESCRIPTION

- A. Land situated in Section 2, T4N, R4W, City of Grand Ledge, Eaton County, Michigan, described as: commencing on the East line of Lot 10, Block 1, Riverside Addition to the City of Grand Ledge, at a point 30 feet South from the South wall of the brick factory building of the Grand Ledge Chair Company; thence due East 5 rods; thence North to Grand River; thence Northwesterly along the river to the East line of Lot 10; thence South along the line of Lot 10 to the place of beginning.
- B. Lot 10, Block 1, Riverside Addition, except the South 181 feet thereof, City of Grand Ledge, Eaton County, Michigan, as recorded in Liber 1 of Plats, Page 63, Eaton County Records.
- C. Lots 6 and 7, Block 2, Riverside Addition, City of Grand Ledge, Eaton County, Michigan, as recorded in Liber 1 of Plats, Page 63, Eaton County Records.
- D. Commencing at a point on the West line of Perry Street, 30 feet North from the South line of Lot 7, Block 2, Riverside Addition; thence East to the East line of Perry Street; thence North to Grand River; thence Northwesterly down said river to the Southeasterly line of right of way of Pere Marquette Railroad; thence Southwesterly along the Southeasterly line of the right of way of said railroad to a point 32 rods North of the South line of Section 2; thence East parallel to said South 10 rods; thence East  $7\frac{1}{2}$  rods; thence South 2 rods; thence South 2 rods; thence East 5 rods; thence North 10 rods; thence East on the South line of Dillon Street, so-called, to the Northeast corner of Lot 7, Block 2, Riverside Addition; thence South 36 feet to the place of beginning, being a part of Supervisor's Plat No. 6, City of Grand Ledge, Eaton County, Michigan is recorded in Liber 2 of Plats, page 49, Eaton County Records.
- E. Commencing 46 rods East and 18 rods North of the Southwest corner of said Section 2; thence North 12 rods; thence East 5 rods; thence South 12 rods; thence West 5 rods to the point of beginning, City of Grand Ledge, Eaton County, Michigan.
- F. The North 15 feet of Lots 397 and 398, Supervisor's Plat No. 6, City of Grand Ledge, Eaton County, Michigan, as recorded in Liber 2 of Plats, Page 49, Eaton County Records.

Subject to the rights of the public and any governmental unit in any part thereof, taken, used or deeded for street, road or highway purposes.

Subject to easements and restrictions of record.

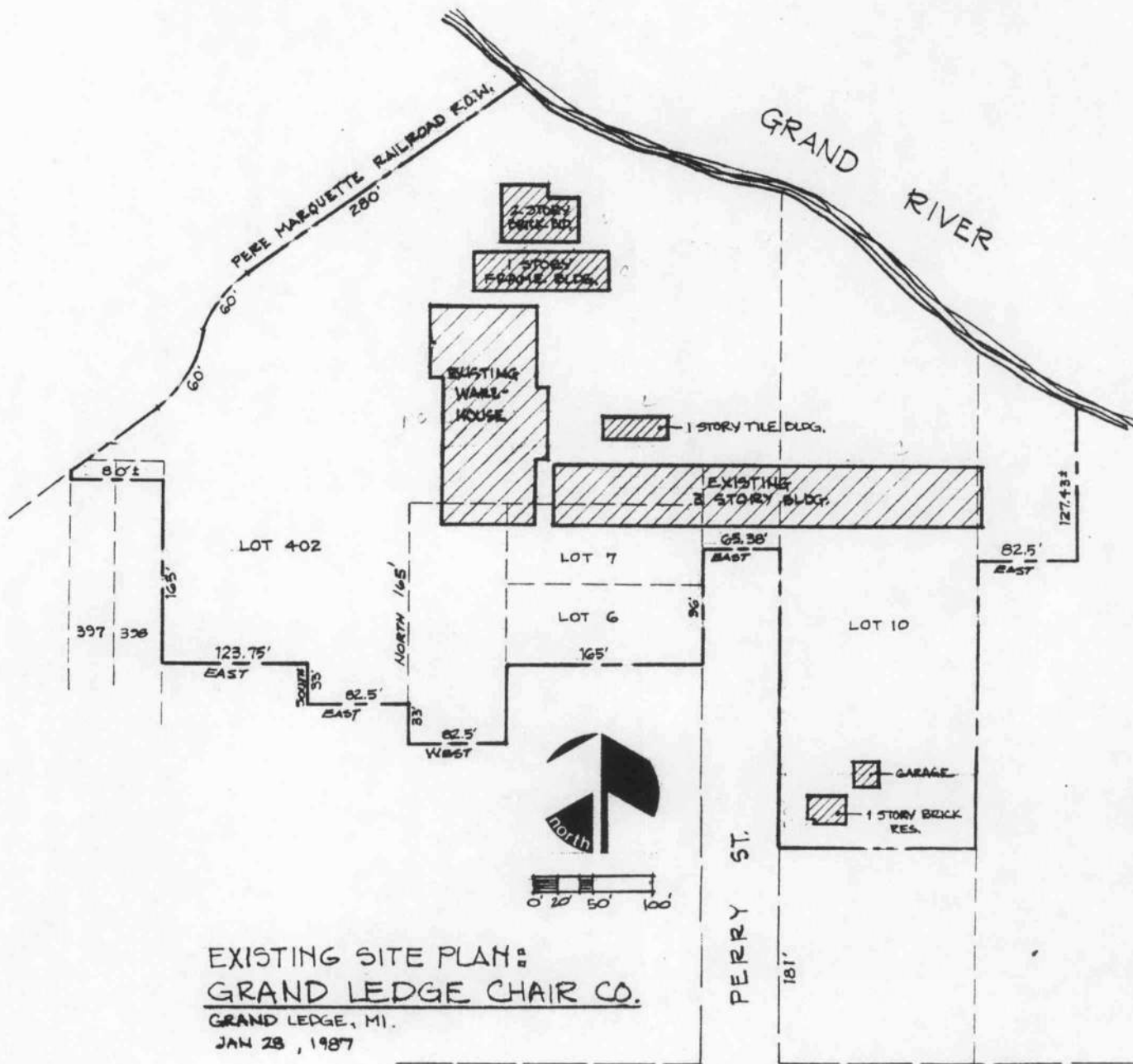

WEST JEFFERSON ST.

M-43

United States Department of the Interior  
National Park Service

RECEIVED

AUG 10 1987

National Register of Historic Places  
Registration Form

NATIONAL  
REGISTER

This form is for use in nominating or requesting determinations of eligibility for individual properties or districts. See instructions in *Guidelines for Completing National Register Forms* (National Register Bulletin 16). Complete each item by marking "x" in the appropriate box or by entering the requested information. If an item does not apply to the property being documented, enter "N/A" for "not applicable." For functions, styles, materials, and areas of significance, enter only the categories and subcategories listed in the instructions. For additional space use continuation sheets (Form 10-900a). Type all entries.

1. Name of Property

historic name None  
other names/site number River Ledge Historic District

2. Location Jefferson, Scott, and Lincoln Streets

street & number between Franklin and Maple Streets N/A not for publication  
city, town Grand Ledge N/A vicinity  
state Michigan code 026 county Eaton code 045 zip code 48837

3. Classification

Ownership of Property	Category of Property	Number of Resources within Property	
<input checked="" type="checkbox"/> private	<input type="checkbox"/> building(s)	Contributing	Noncontributing
<input checked="" type="checkbox"/> public-local	<input checked="" type="checkbox"/> district	<u>235</u>	<u>47</u> buildings
<input type="checkbox"/> public-State	<input type="checkbox"/> site	_____	_____ sites
<input type="checkbox"/> public-Federal	<input type="checkbox"/> structure	_____	_____ structures
	<input type="checkbox"/> object	<u>235</u>	<u>47</u> objects
			Total

Name of related multiple property listing:  
N/A

Number of contributing resources previously listed in the National Register 0

4. State/Federal Agency Certification

As the designated authority under the National Historic Preservation Act of 1966, as amended, I hereby certify that this  nomination  request for determination of eligibility meets the documentation standards for registering properties in the National Register of Historic Places and meets the procedural and professional requirements set forth in 36 CFR Part 60. In my opinion, the property  meets  does not meet the National Register criteria.  See continuation sheet.

*Martha M. Bigelow* 7/31/87  
Signature of certifying official Date  
Director, Bureau of History  
State or Federal agency and bureau

In my opinion, the property  meets  does not meet the National Register criteria.  See continuation sheet.

\_\_\_\_\_  
Signature of commenting or other official Date  
\_\_\_\_\_  
State or Federal agency and bureau

5. National Park Service Certification

I, hereby, certify that this property is:

entered in the National Register. *Beth Casanova* 9/24/87  
 See continuation sheet. \_\_\_\_\_  
 determined eligible for the National Register.  See continuation sheet. \_\_\_\_\_  
 determined not eligible for the National Register. \_\_\_\_\_  
 removed from the National Register. \_\_\_\_\_  
 other, (explain:) \_\_\_\_\_

\_\_\_\_\_  
Signature of the Keeper Date of Action

## 6. Function or Use

Historic Functions (enter categories from instructions)

Domestic/single dwelling

Religion/religious structure

Current Functions (enter categories from instructions)

Domestic/single dwelling

Religion/religious structure

Government/city hall

## 7. Description

Architectural Classification

(enter categories from instructions)

Italianate

Queen Anne

Colonial Revival

Materials (enter categories from instructions)

foundation Stone

walls Wood/weatherboard

Brick

roof Asphalt

other

Describe present and historic physical appearance.

The River Ledge Historic District is an irregularly shaped residential area about one-half mile in length and 700 feet in width located on the southwest side of the Grand River in the city of Grand Ledge. The district contains a total of 282 buildings (235 of them contributing), of which all but eight were constructed as housing. Virtually all the houses were built as single-family residences. The structures date generally from the 1850s to 1920s and exemplify a broad range of architectural styles and building types popular in southern Michigan in that period.

The River Ledge district contains the historic core of Grand Ledge's southside residential neighborhood. Located on a plateau atop the yellow-brown, Pennsylvanian sandstone and shale bluffs (which give the city its name) overlooking the Grand River, the district skirts around the south side of the city's small central business district, located along Bridge Street (M-100) south of the Grand River bridge. Streets are laid out at right angles, forming square blocks, except at the district's west end, where the streets often intersect at angles, creating pleasant vistas. Most of the streets are narrow. Even East Jefferson, a four-lane roadway which serves as part of state route M-100, appears narrow because of its narrow traffic lanes and lack of flanking parking lanes. Large, old trees, particularly maples, flank many roadsides and shade many houses. The plentiful shade trees and the siting of the houses well back from the street line and separate from each other give the district a spacious character.

The Grand Ledge district contains four brick or stuccoed, late nineteenth- and early twentieth-century churches located around the fringes of the downtown area, a fifth church that has in recent years been converted into the Grand Ledge City Hall, and the early twentieth-century public library, with its large, modern addition — actually the main structure — tucked unobtrusively behind it.

Out of the district's 282 structures, however, 264 were built as houses. Although several now serve as funeral homes or contain real estate offices or other commercial uses, nearly all serve as houses. Clapboard or clapboard and shingle exteriors predominate, but some brick and stone structures, and a few cement block ones, are present. Ten large carriage houses/barns are present. One has walls constructed of glazed-finish, locally manufactured conduit tile.

Most houses in the district are relatively modest in size and simple in their detailing. The largest and most elaborately detailed homes are generally concentrated along East and West Jefferson. The district houses exemplify Greek and Gothic Revival, Italianate, Queen Anne, Colonial Revival, and bungalow/craftsman styling. Frame, one- or two-story, cubical Italianate houses, L-shaped houses with Gothic gable windows, and narrow-fronted and deep Queen Anne/Colonial Revival houses establish the district character. However, a large number of Late Victorian homes are very simply detailed structures which contain no identifiable stylistic references, but have plain, square-head windows and simple raking cornices without returns.

United States Department of the Interior  
National Park Service

# National Register of Historic Places Continuation Sheet

Section number 7 Page 2

Alterations which some district structures have undergone include the modernization with colonial or craftsman detailing of numerous nineteenth-century structures and, more recently, siding with asphalt, asbestos, aluminum, and vinyl sidings and the removal of porches or replacement of old wooden porch supports with wrought iron ones. However, these changes have not affected a high proportion of the district structures or greatly affected the district's historic character.

The following buildings contribute to the historic character of the district (all are wood-frame houses unless otherwise indicated):

205 Adams St.	c. 1900 end-gable
406 S. Bridge St.	Free Methodist Church (now 1st United Methodist Church annex): c. 1900 stucco-clad structure with corner tower
417 S. Bridge St.	c. 1900 end-gable
418 " " "	c. 1900 Colonial Revival
419 " " "	Late Victorian hip-roof cottage
426 " " "	c. 1900 cement block with stuccoed gables
427 " " "	Late Victorian L-plan
501 " " "	c. 1900 gambrel-roof Colonial Revival
700 DeGroff St.	Late Victorian hip-roof cottage
211 Franklin St.	Late Victorian L-plan
214 " " "	Bungalow
316 " " "	Bungalow-style
319 " " "	Late Victorian L-plan
327 " " "	2-story, hip-roof, Late Victorian
212 Harrison St.	Late Victorian hip-roof
216 " " "	Late Victorian L-plan
314 " " "	Late Victorian with Gothic windows
315 " " "	Queen Anne
316 " " "	Late Victorian hip-roof cottage
321 " " "	Queen Anne
326 " " "	Queen Anne
327 " " "	Queen Anne
410 " " "	Colonial Revival
411 " " "	First United Methodist Church (1911-12): brick Gothic structure
418 " " "	c. 1900 hip-roof cottage
426 " " "	Queen Anne
312 Jackson St.	Bungalow-style
317 " " "	Hip-roof Late Victorian
320 " " "	Queen Anne/Colonial Revival
327 " " "	Late Victorian L-plan
328 " " "	Brick Queen Anne/Colonial Revival
410 " " "	Late Victorian end-gable
411 " " "	Late Victorian/early 20th-c. cottage
418 " " "	Bungalow
419 " " "	Queen Anne/Colonial Revival
423 " " "	Brick Queen Anne/Colonial Revival
427 " " "	Late Victorian L-plan

United States Department of the Interior  
National Park Service

National Register of Historic Places  
Continuation Sheet

Section number 7 Page 3

131 E. Jefferson St.	Grand Ledge Public Library (1931): red-brick, Renaissance Revival-style structure with green tile roof. Large rear wing (1958) is now the main library.
201 E. Jefferson St.	Trinity Episcopal Church (1911-13): brick, Gothic structure with corner tower
207 " " "	Buff brick Italianate with belvedere (1872-73)
214 " " "	Queen Anne
219 " " "	Queen Anne
220 " " "	Queen Anne
301 " " "	Brick Italianate
302 " " "	Italianate
308 " " "	Queen Anne/Colonial Revival
310 " " "	Italianate
315 " " "	Gambrel-roof Colonial Revival
318 " " "	Brick Queen Anne
324 " " "	Late Victorian L-plan
327 " " "	Brick Italianate
328 " " "	Queen Anne/Colonial Revival
332 " " "	Late Victorian
400 " " "	Bungalow-style
403 " " "	Late Victorian L-plan
406 " " "	Brick Italianate
407 " " "	Brick c. 1900
411 " " "	Stuccoed Italianate
412 " " "	Brick early 20th-C., hip-roof
419 " " "	Brick c. 1900
420 " " "	Italianate
424 " " "	c. 1900 Colonial Revival
431 " " "	Late Victorian L-plan
500 " " "	c. 1900 end-gable
501 " " "	Brick bungalow
504 " " "	Late Victorian L-plan
510 " " "	c. 1900 end-gable
511 " " "	c. 1900 flank-gable
514 " " "	Late Victorian brick L-plan
515 " " "	Bungalow
520 " " "	Italianate
521 " " "	c. 1900 end-gable
527 " " "	c. 1900 end-gable
600 " " "	Brick Queen Anne
603 " " "	Colonial flank-gable (1928)
119 W. Jefferson St.	Brick Late Victorian
200 " " "	Shingle Style
204 " " "	Evidently c. 1900 house modernized in the 1920s
207 " " "	c. 1900 cement block end-gable
210 " " "	c. 1900 brick end-gable
211 " " "	c. 1900 cement block Colonial Revival
219 " " "	Brick flank-gable Colonial Revival
226 " " "	Late Victorian L-plan
227 " " "	Flank-gable Late Victorian

United States Department of the Interior  
National Park Service

National Register of Historic Places  
Continuation Sheet

Section number 7 Page 4

304	"	"	"	Queen Anne
315	"	"	"	Brick Colonial Revival
316	"	"	"	Queen Anne
324	"	"	"	Cement block bungalow
325	"	"	"	Queen Anne
330	"	"	"	Bungalow
333	"	"	"	Foursquare
334	"	"	"	Late Victorian
335	"	"	"	Foursquare
339	"	"	"	Flank-gable Colonial Revival
342	W. Jefferson St.	"	"	c. 1900 saltbox
345	"	"	"	c. 1900 end-gable
348	"	"	"	c. 1900 brick end-gable
354	"	"	"	c. 1900
360	"	"	"	Bungalow
400	"	"	"	Modern English c. 1920s
405-407	"	"	"	L-plan with Gothic windows
408	"	"	"	c. 1920s jerkinhead-roof
412	"	"	"	c. 1900 brick Queen Anne/Colonial Revival
413	"	"	"	Queen Anne/Colonial Revival
420	"	"	"	c. 1900 end-gable
421	"	"	"	Queen Anne
427	"	"	"	Queen Anne
430	"	"	"	Brick bungalow-style
502	"	"	"	Queen Anne
503	"	"	"	Queen Anne/Colonial Revival
508	"	"	"	Queen Anne
109	E. Lincoln St.	"	"	Queen Anne/Colonial Revival
115	"	"	"	Late Victorian flank-gable
116	"	"	"	Bungalow-style
119	"	"	"	Late Victorian hip-roof cottage
125	"	"	"	c. 1900 end-gable
200	"	"	"	L-plan with Gothic windows
209	"	"	"	Late Victorian hip-roof cottage
216	"	"	"	c. 1900 L-plan
219	"	"	"	Stuccoed cross-gable, 1920s
224	"	"	"	Brick Italianate
227	"	"	"	Flank-gable Late Victorian
301	"	"	"	L-plan with Gothic windows
304	"	"	"	Late Victorian flank-gable
307	"	"	"	Late Victorian hip-roof cottage
308	"	"	"	Late Victorian flank-gable
315	"	"	"	Late Victorian hip-roof
316	"	"	"	Late Victorian hip-roof
320	"	"	"	Late Victorian flank-gable
325	"	"	"	Flank-gable Colonial
326	"	"	"	c. 1900 flank-gable
401	"	"	"	L-plan with Gothic windows

United States Department of the Interior  
National Park Service

# National Register of Historic Places Continuation Sheet

Section number 7 Page 5

409	"	"	"	Bungalow
412	"	"	"	Bungalow
414	"	"	"	Bungalow
428	"	"	"	Strobel Funeral Home (1930): flank-gable, brick, Federal Revival structure, now a house
112-114	W.	Lincoln	St.	Late Victorian L-plan
118	"	"	"	Jerkinhead-roof Late Victorian with pendentive ornaments under eaves
201	"	"	"	Late Victorian L-plan
208	"	"	"	Late Victorian hip-roof
215	"	"	"	Towered brick Late Victorian
219	"	"	"	c. 1900 cross-gable
220	"	"	"	Queen Anne
223	"	"	"	Queen Anne
226	"	"	"	Queen Anne/Colonial Revival
227	"	"	"	c. 1900 end-gable
232	"	"	"	Queen Anne
236	"	"	"	Late Victorian flank-gable
240	"	"	"	End-gambrel-roof Colonial Revival
213	Maple	St.		c. 1900 end-gable
214	"	"		c. 1900 end-gable
217	"	"		Late Victorian flank-gable
218	"	"		Late Victorian hip-roof
313	Pleasant	St.		Late Victorian hip-roof
316	"	"		Late Victorian L-plan
321	"	"		Late Victorian L-plan
408	"	"		c. 1900 end-gable
409	"	"		Late Victorian hip-roof
414	"	"		c. 1900 end-gable
415	"	"		Queen Anne/Colonial Revival
421	"	"		Late Victorian hip-roof
422	"	"		c. 1900 end-gable
426	"	"		c. 1900 end-gable
427	"	"		Late Victorian hip-roof
205	W.	River	St.	Late Victorian L-plan
213	"	"	"	Late Victorian L-plan
228	"	"	"	Late Victorian L-plan
238	"	"	"	Stuccoed bungalow
207	Russell	St.		Greek Revival L-plan
114	E.	Scott	St.	Queen Anne
118	"	"	"	Towered Late Victorian
200	"	"	"	Stuccoed Late Victorian hip-roof
206	"	"	"	Late Victorian hip-roof
212	"	"	"	Queen Anne
220	"	"	"	Bungalow-style
221	"	"	"	Large Colonial Revival
226	"	"	"	Queen Anne
231	"	"	"	Colonial Revival
235	"	"	"	c. 1900 end-gable

United States Department of the Interior  
National Park Service

National Register of Historic Places  
Continuation Sheet

Section number 7 Page 6

300	"	"	"	Late Victorian cross-gable
306	"	"	"	Queen Anne
313	"	"	"	Late Victorian hip-roof
322	"	"	"	Late Victorian L-plan
323	"	"	"	c. 1900 cross-gable
328	"	"	"	Queen Anne/Colonial Revival
400	"	"	"	Brick Queen Anne
409-411	"	"	"	Early 20th-C. hip-roof
415	"	"	"	Late Victorian L-plan
421	"	"	"	c. 1900 end-gable
502	"	"	"	Late Victorian hip-roof
514	"	"	"	Bungalow-style
518	"	"	"	c. 1900
519	"	"	"	Colonial
521	"	"	"	Colonial
524	"	"	"	Late Victorian hip-roof
600	"	"	"	Stuccoed 1920s English
204 W. Scott St.				Queen Anne/Colonial Revival
205	"	"	"	First Baptist Church, now Church of God (1874, 1931): brick, Gothic structure with 1931 tower at corner
212	"	"	"	Late Victorian L-plan
216	"	"	"	Queen Anne
220	"	"	"	Queen Anne
225	"	"	"	Queen Anne/Colonial Revival
226	"	"	"	Queen Anne/Colonial Revival
231	"	"	"	L-plan with Gothic windows
303	"	"	"	Late Victorian L-plan
304	"	"	"	Greek Revival end-gable
307	"	"	"	Late Victorian hip-roof
317	"	"	"	Late Victorian hip-roof
325	"	"	"	Late Victorian L-plan
218 Spring St.				Late Victorian end-gable
224	"	"	"	Late Victorian end-gable
309	"	"	"	Late Victorian hip-roof
311 Summer St.				Italianate
312 Taylor St.				Queen Anne
316-316 1/2	"	"	"	Queen Anne/Colonial Revival
318-20	"	"	"	Brick Late Victorian
319	"	"	"	Italianate
327	"	"	"	Late Victorian L-plan
409	"	"	"	Queen Anne
410	"	"	"	Queen Anne/Colonial Revival
418	"	"	"	Queen Anne/Colonial Revival
419	"	"	"	Bungalow
421	"	"	"	Cross-gable c. 1900
427	"	"	"	Queen Anne
500	"	"	"	L-plan with Gothic windows
407 E. Jefferson St.				Barn

United States Department of the Interior  
National Park Service

National Register of Historic Places  
Continuation Sheet

Section number 7 Page 7

119 W. Jefferson St. Carriage house  
315 " " " Carriage house/barn  
408 " " " Carriage house/barn  
412 " " " Carriage house/barn  
430 " " " Carriage house/barn  
432 " " " Carriage house/barn  
428 E. Lincoln St. Carriage house (1909) built of conduit tile from  
Local Grand Ledge Clay Products Co.  
238 W. River St. Carriage house  
518 E. Scott St. Barn

The following buildings do not contribute to the district's historic character:

209 Adams St. Denatured c. 1900 end-gable  
311 Harrison St. Modern house  
321 Jackson St. Modern House  
426 Jackson St. Denatured Queen Anne  
200 E. Jefferson St. City Hall, built 1940 as Catholic church, remodeled 1970 as city hall  
319 " " " Denatured Queen Anne  
425 " " " Denatured Late Victorian L-plan  
524 " " " Modern house  
127 W. Jefferson St. Denatured Late Victorian  
201 " " " Former service station  
214 " " " Denatured Late Victorian L-plan  
220 " " " Denatured Late Victorian L-plan  
310 " " " Denatured Queen Anne  
432 " " " Denatured Queen Anne  
410 Liberty St. Modern house  
411 " " " Denatured c. 1900  
415 " " " Modern house  
211 E. Lincoln St. Modern house  
300 " " " Modern house  
319 " " " Denatured old house  
400 " " " Denatured Late Victorian  
416 " " " Denatured early 20th-C.  
108 W. Lincoln St. Denatured Late Victorian hip-roof  
124 " " " Denatured Colonial Revival  
214 " " " Denatured Queen Anne  
229 " " " Denatured Late Victorian L-plan  
415 Park St. Modern house  
303 Pleasant St. Denatured Late Victorian L-plan  
307 " " " Denatured c. 1900  
310 " " " Denatured c. 1900 end-gable  
401 " " " Denatured Late Victorian hip-roof  
209 W. River St. Denatured Late Victorian L-plan  
222 " " " Denatured old house  
211 Russell St. Denatured Late Victorian end-gable  
218 " " " Denatured Queen Anne

United States Department of the Interior  
National Park Service

National Register of Historic Places  
Continuation Sheet

Section number 7 Page 8

---

124 E. Scott St.	Italianate remodeled as church
213 " " "	Modern house
303 " " "	Denatured Late Victorian hip-roof
305 " " "	Denatured Late Victorian hip-roof
312 " " "	Denatured Late Victorian
401 " " "	Denatured Queen Anne
408 " " "	Denatured c. 1900
412 " " "	Denatured early 20th-C.
418 " " "	Denatured Italianate
515 " " "	Denatured old house
219 W. Scott St.	Denatured Queen Anne
317 Summer St.	Modern House



**Front - Title/Description**

***Fitzgerald Park***

Migrant Indian tribes led by the famous Chief Okemos called this area "Big Rocks." They came here in early spring to tap the sugar maples. Later, the beauty of the ledges and woods attracted the Grand Ledge Spiritualist Camp Association, which, in 1894, established a summer campground and erected the large pavilion which still stands. Thousands of spiritualists came here for summer encampments until the turn of the century. In 1919 the city of Grand Ledge bought the property and named it Riverside Park. The pavilion was used for dances, roller skating, and basketball. During World War II it housed a factory. This park's name commemorates Grand Ledge native Governor Frank D. Fitzgerald, who died in office in 1939. The pavilion was refurbished as a summer theater by the Grand Ledge Improvement Association in 1955.

**Significant Date:**

Industry and Invention (1875-1915)

**Registry Year:** 1978    **Erected Date:** 1978

**Marker Location**

**Address:** 3808 Grand Ledge Highway

**City:** Grand Ledge

**State:** MI    **ZipCode:**

**County:** Eaton

**Township:** Oneida

**Lat:** 42.75979900 / **Long:** -84.76086800

**Web URL:**

**Back - Title/Description**

**Historical Marker - S511A - Governor Frank D. Fitzgerald Home / Governor Frank D. Fitzgerald Home (Marker ID#:S511A)**



**Front - Title/Description**

**Governor Frank D. Fitzgerald Home**

Here lived Frank D. Fitzgerald who served his first term as governor 1935-1936. His second term, starting in January 1939, was cut short by his death in this house in March of that year. Born in Grand Ledge in 1885, Fitzgerald earned wide respect from local citizens. A Republican, he was secretary of state 1930-1934. State chief executive during some tumultuous depression years, Fitzgerald advocated government reorganization measures, including a civil service system for state employees.

**Back - Title/Description**

**Governor Frank D. Fitzgerald Home**

Governor Fitzgerald acquired this house during his first gubernatorial term. At that time the state did not provide an official mansion; thus Fitzgerald used this home as the governor's residence. Out of office 1937-38, he planned his successful reelection campaign from here. Lansing architect Edwyn C. Bowd designed the residence in 1907. It was built for eighteen thousand dollars. The house was set on a high foundation. The tile roof, massive chimneys, and rounded bay windows are Romanesque style.

**Significant Date:**

Industry and Invention (1875-1915)

**Registry Year:** 1978    **Erected Date:** 1979

**Marker Location**

**Address:** 219 West Jefferson

**City:** Grand Ledge

**State:** MI    **ZipCode:**

**County:** Eaton

**Township:** Oneida

**Lat:** 42.75454000 / **Long:** -84.74798000

**Web URL:**

## Historical Marker - L592 - Second Island (Marker ID#:L592)



### Front - Title/Description

#### *Second Island*

Graced by the natural beauty of these soaring sandstone ledges, Grand Ledge was once famous for its Seven Islands Resort, a recreation area centered on this island from 1870 to 1910. At the turn of the century the ledges made this city one of the most popular resort areas in lower Michigan. Excursion trains brought thousands to enjoy this area, which featured steamboat rides, a boat livery, a hotel and vaudeville theater, mineral wells, a roller coaster, and fishing. In 1976 the Grand Ledge Area Bicentennial Commission erected the band pavilion.

#### **Significant Date:**

Civil War and After (1860-1875)

**Registry Year:** 1978    **Erected Date:** 1989

### Marker Location

**Address:** Second Island, Grand River

**City:** Grand Ledge

**State:** MI    **ZipCode:**

**County:** Eaton

**Township:** Oneida

**Lat:** 42.75514900 / **Long:** -84.74620900

**Web URL:**

### Back - Title/Description

## Historical Marker - L1943 - Blake's Opera House (Marker ID#:L1943)



### Front - Title/Description

#### **Blake's Opera House**

Constructed in 1884 as a roller skating rink, this building was purchased by Peter Blake and opened as Blake's Opera House in 1886. Here audiences enjoyed talent shows, vaudeville, silent movies, and athletic contests. Between 1928 and 1984 the Stephens and Mapes families used the building as a furniture store. The Mapes family donated the building for a community center. It was restored by the Grand Ledge Area Historical Society and the chamber of commerce.

#### **Significant Date:**

Industry and Invention (1875-1915)

**Registry Year:** 1995    **Erected Date:** 2000

### Back - Title/Description

#### **Marker Location**

**Address:** 121 S. Bridge Street

**City:** Grand Ledge

**State:** MI    **ZipCode:**

**County:** Eaton

**Township:** Oneida

**Lat:** 42.75394000 / **Long:** -84.74491500

**Web URL:**

# Appendix 2

---

**Grand Ledge Sewer  
EQUIPMENT REPLACEMENT PAGE 2**

**2023**

MID-TERM ASSETS 15-30 YEARS

FIXED ASSET INVENTORY		ASSET REPLACEMENT SCHEDULE					
EQUIPMENT LIST / MAINTENANCE ACTIVITY	DESCRIPTION / MAINTENANCE HISTORY	ORIGINAL INSTALLATION YEAR	NORMAL INTENDED USEFUL LIFE	CURRENT AGE	NEXT REPLACEMENT YEAR	REMAINING LIFE - YEARS BEFORE REPLACEMENT	TOTAL REPLACEMENT COST
<b>/Screening Room</b>							
Bar Screen		2011	20	12	2031	8	\$70,000
Washing Screw Compactor		2011	20	12	2031	8	\$45,000
Controls		2011	20	12	2031	8	\$25,000
Recycle Pump	In O & M budget	2011	20	12	2031	8	\$1
Electric Controls	In O & M budget	2011	20	12	2031	8	\$1
Gas Detectors	In O & M budget	2019	5	4	2024	1	\$1
Exhaust Fan	In O & M budget	2011	20	12	2031	8	\$1
Chlorine Tablet	In O & M budget	2011	20	12	2031	8	\$1
Muffin Monster		2011	25	12	2036	13	\$10,000
MAINTENANCE BLD - ROOF ETC.		2011	20	12	2031	8	\$40,000
ELECTRICAL PANELS		2011	25	12	2036	13	\$20,000
<b>Grit Building</b>							
Sampler for Influent	In O & M budget	2019	10	4	2029	6	\$1
Grit Blower and 10 H.P. Motor		2011	15	12	2026	3	\$22,500
Exhaust Fan	In O & M budget	2011	20	12	2031	8	\$1
Parshall Flume	In O & M budget	2011	30	12	2041	18	\$1
Influent Flow Meter	In O & M budget	2011	15	12	2026	3	\$1
<b>Chlorine Room</b>							
Chlorine Pace Unit	In O & M budget	2019	10	4	2029	6	\$1
(2) Chlorine Regulators	In O & M budget	2018	10	5	2028	5	\$1
Chlorine Gas Leak Detector	In O & M budget	2011	15	12	2026	3	\$1
Final Effluent Flow Meter	In O & M budget	2011	10	12	2023	0	\$1
<b>Pump Room</b>							
1 Lobe Pro Sludge Pumps 15 H.P. 1		2018	10	5	2028	5	\$18,000
Lobe Pro Sludge Pumps 15 H.P. 2		2019	10	4	2029	6	\$18,000
Return Pumps 15 H.P. 1		2020	12	3	2032	9	\$28,000
Return Pumps 15 H.P. 2		2020	12	3	2032	9	\$28,000
Return Pumps 15 H.P. 3		2013	12	10	2025	2	\$28,000
(2) Effluent Pumps 10 H.P.	In O & M budget	2012	20	11	2032	9	\$1
Power Valve	In O & M budget	2014	10	9	2024	1	\$1
(3) "Mags" Return Sludge Waste	ONE REPLACED ON WAS 2019.	2009	15	14	2024	1	\$15,000
Cummins Diesel Powered Generator - NEW 2011 40 YRS		2011	30	12	2041	18	\$150,000
<b>Intermediate Lift Station</b>							
(3) 15 H.P. Submersible Pumps		2011	20	12	2031	8	\$42,000
Hoist for Pump Service	In O & M budget	2011	30	12	2041	18	\$1
Electric Panel and Controls		2011	20	12	2031	8	\$10,000
<b>Primary Tanks (2)</b>							
Flight Drive		2020	30	3	2050	27	\$30,000
Cross Screws		1975	46	48	2023	0	\$12,500
Replacement Chain/Flights		2009	15	14	2024	1	\$22,140
<b>Aeration Tanks</b>							
Replacement Membranes for All Diffusers		2009	15	14	2024	1	\$15,000
<b>Blower Room</b>							
Centrifugal Blowers 1		2014	15	9	2029	6	\$33,000
Centrifugal Blowers 2		2007	15	16	2023	0	\$90,000
Centrifugal Blowers 3		2010	15	13	2025	2	\$33,000
							<b>\$805,156</b>

# Grand Ledge Sewer

## EQUIPMENT REPLACEMENT PAGE 3

2023

FIXED ASSET INVENTORY		ASSET REPLACEMENT SCHEDULE				
EQUIPMENT LIST / MAINTENANCE ACTIVITY	DESCRIPTION / NOTES	ORIGINAL INSTALLATION YEAR	NORMAL INTENDED USEFUL LIFE	CURRENT AGE	NEXT REPLACEMENT YEAR	TOTAL REPLACEMENT COST
<b>Final Clarifier Drives</b>						
(1) Final Drive Gearbox/Clarifier		2020	45	3	2065	\$185,000
(1) Final Drive Gearbox/Clarifier		2019	45	4	2064	\$185,000
<b>Chemical Feed Room</b>						
Lime Pumps 1	In O & M budget	2013	15	10	2028	\$1
Lime Pumps 2	In O & M budget	2010	15	13	2025	\$1
Ferric Pumps (2)	In O & M budget	2014	15	9	2029	\$1
Bisulfite Pumps	In O & M budget	2019	15	4	2034	\$1
5,000 Gallon Ferric Tanks (2)		2016	20	7	2036	\$27,942
Pulse Dampeners for Lime Pumps (2)	In O & M budget	2014	25	9	2039	\$1
Lime Dust Collector	In O & M budget	1982	40	41	2023	\$1
<b>Lab Equipment</b>						
Spectrophotometer	In O & M budget	2016	10	7	2026	\$1
"Top Loader" Scale	In O & M budget	2005	20	18	2025	\$1
"Door Scale"	In O & M budget	2000	20	23	2023	\$1
Drying Oven	In O & M budget	2019	20	4	2039	\$1
pH Meter	In O & M budget	2016	10	7	2026	\$1
Muffle Furnace	In O & M budget	2017	10	6	2027	\$1
BOD Incubator	In O & M budget	2014	15	9	2029	\$1
Autoclave	In O & M budget	2012	15	11	2027	\$1
BOD Meter	In O & M budget	2017	8	6	2025	\$1
Water Softener	In O & M budget	2000	20	23	2023	\$1
Primary Sampler	In O & M budget	2010	15	13	2025	\$1
Final Sampler	In O & M budget	2008	15	15	2023	\$1
Scada Computer	In O & M budget	2020	1	3	2023	\$1
Scada Computer Backup	In O & M budget	2020	7	3	2027	\$1

# Grand Ledge Sewer

## EQUIPMENT REPLACEMENT PAGE 3

2023

FIXED ASSET INVENTORY		ASSET REPLACEMENT SCHEDULE				
EQUIPMENT LIST / MAINTENANCE ACTIVITY	DESCRIPTION / NOTES	ORIGINAL INSTALLATION YEAR	NORMAL INTENDED USEFUL LIFE	CURRENT AGE	NEXT REPLACEMENT YEAR	TOTAL REPLACEMENT COST
SCADA SOFTWARE	In O & M budget	2020	20	3	2040	\$0
<b>Miscellaneous</b>						
Heat and A/C Unit for WWTP on Roof	In O & M budget	2010	20	13	2030	\$1
ROOF - MAIN WWTP BUILDING		2019	20	4	2039	\$35,000
<b>Vehicles</b>						
Vactor		2021	10	2	2033	\$450,000
Camera Truck		2013	15	10	2028	\$75,000
2017 Dodge PICKUP INCLUDES PLOW & SERVICE BODY		2017	8	6	2025	\$50,000
Crane/Hoist	In O & M budget	2014	20	9	2034	\$1
ROOFS - GRIT, INTERMEDIATE LS, VALVE, CONTROL BLD		1997	20	26	2023	\$15,000
						<b>\$1,022,964</b>

**Grand Ledge Sewer**

**EQUIPMENT REPLACEMENT SHORT LIVED ASSETS**

2023

SHORT LIVED ASSETS SOMEWHERE BETWEEN 0-15 OR 20 YEARS

YOUR ANTICIPATED NORMAL INTENDED USEFUL LIFE OR YEARS BETWEEN REHAB BASED ON PAST MAINTENANCE HISTORY, WELL MAINTENANCE RECORDS AND WA INSPECTION REPORTS. - A COPY OF THESE REPORTS SHOULD BE INCLUDED IN Y EVALUATION AS AN ATTACHMENT OR APPENDIX -- ALSO NOTE; IF YOU ARE APPLIN RURAL DEVELOPMENT GRANT OR HOPE TO GET A USDA GRANT - THE REMAINING Y FOR ANY EQUIPMENT CAN NOT EXCEED 15 YEARS. FOR ANYTHING - WATER METERS' PAINTING ETC. ONCE THE USEFUL LIFE OR NEXT ANTICIPATED MAINTENANCE IS LE YEARS AWAY IT CAN BE LISTED HERE,

FIXED ASSET INVENTORY		ASSET REPLACEMENT SCHEDULE					
EQUIPMENT LIST / MAINTENANCE ACTIVITY	DESCRIPTION / MAINTENANCE HISTORY	ORIGINAL INSTALLATION YEAR OR LAST REHAB YEAR	ESTIMATED NORMAL INTENDED USEFUL LIFE	CURRENT AGE	NEXT ANTICIPATED REPLACEMENT YEAR	REMAINING LIFE - YEARS BEFORE REPLACEMENT	TOTAL REPLACEMENT COST
<b>Eaton Hwy</b>							
(2) Pumps		2010	15	13	2025	2	\$17,300
ELECTRIC PANEL & CONTROLS	In O & M budget	2019	25	4	2044	21	\$1
<b>Loch Ledge</b>							
(2) Pumps		2005	15	18	2023	0	\$16,000
ELECTRIC PANEL & CONTROLS	In O & M budget	2010	25	13	2035	12	\$1
<b>Burt Ave</b>							
(2) Pumps	In O & M budget	2017	15	6	2032	9	\$1
ELECTRIC PANEL & CONTROLS	In O & M budget	1990	25	33	2023	0	\$1
<b>Whitney St</b>							
(2) Pumps		2008	15	15	2023	0	\$15,000
ELECTRIC PANEL & CONTROLS	In O & M budget	2018	25	5	2043	2023	\$1
(2) Motors	In O & M budget	2008	15	15	2023	0	\$1
<b>W River St</b>							
Pump 1	NEW 2021	2021	5	2	2026	3	\$18,000
PUMP 2	NEW 2021	2021	5	2	2026	3	\$18,000
PUMP 3	NEW 2021	2021	5	2	2026	3	\$18,000
MOTOR 1	In O & M budget	2017	15	6	2032	9	\$1
MOTOR 2	In O & M budget	2021	15	2	2036	13	\$1
MOTOR 3	In O & M budget	2011	15	12	2026	3	\$1
(3) Check Valve 6" - 900 EACH	In O & M budget	1990	35	33	2025	2	\$1
Control Panel Allen Brady	In O & M budget	2010	20	13	2030	7	\$1
Electric Panel/Gear	In O & M budget	2010	20	13	2030	7	\$1
(3) VFD	2 REPLACED IN 2016	2016	15	7	2031	8	\$20,000
Mag/Flowmeter	In O & M budget	2010	20	13	2030	7	\$1
Overflow Mag	In O & M budget	2010	25	13	2035	12	\$1

52 EQUIPMENT REPLACEMENT 1

**Grand Ledge Sewer**

**EQUIPMENT REPLACEMENT SHORT LIVED ASSETS**

2023

SHORT LIVED ASSETS SOMEWHERE BETWEEN 0-15 OR 20 YEARS

YOUR ANTICIPATED NORMAL INTENDED USEFUL LIFE OR YEARS BETWEEN REHAB BASED ON PAST MAINTENANCE HISTORY, WELL MAINTENANCE RECORDS AND WA INSPECTION REPORTS. - A COPY OF THESE REPORTS SHOULD BE INCLUDED IN Y EVALUATION AS AN ATTACHMENT OR APPENDIX -- ALSO NOTE; IF YOU ARE APPLIN RURAL DEVELOPMENT GRANT OR HOPE TO GET A USDA GRANT - THE REMAINING Y FOR ANY EQUIPMENT CAN NOT EXCEED 15 YEARS. FOR ANYTHING - WATER METERS PAINTING ETC. ONCE THE USEFUL LIFE OR NEXT ANTICIPATED MAINTENANCE IS LE YEARS AWAY IT CAN BE LISTED HERE,

FIXED ASSET INVENTORY		ASSET REPLACEMENT SCHEDULE					
EQUIPMENT LIST / MAINTENANCE ACTIVITY	DESCRIPTION / MAINTENANCE HISTORY	ORIGINAL INSTALLATION YEAR OR <u>LAST REHAB YEAR</u>	ESTIMATED NORMAL INTENDED USEFUL LIFE	CURRENT AGE	NEXT ANTICIPATED REPLACEMENT YEAR	REMAINING LIFE - YEARS BEFORE REPLACEMENT	TOTAL REPLACEMENT COST
Generator	Portable	1990	40	33	2030	7	\$50,000
Confined Space Hoist/System	In O & M budget	2016	20	7	2036	13	\$1
BUILDING MAINT - ROOF & HEAT ETC		2015	20	8	2035	12	\$15,000
Generator Stationary		1995	40	28	2035	12	\$50,000
<b>W Jefferson St</b>							
(2) Pumps		2006	20	17	2026	3	\$70,000
Generator		2006	40	17	2046	23	\$80,000
(2) Check Valves	In O & M budget	2006	25	17	2031	8	\$1
(2) VFD Cutler Hammer SUX 9000		2006	20	17	2026	3	\$18,000
(3) Valves Butterfly		2006	25	17	2031	8	\$14,700
Mag Flowmeter	In O & M budget	2006	20	17	2026	3	\$1
Controls Multismart	In O & M budget	2006	20	17	2026	3	\$1
Electric Gear/Panels	In O & M budget	2006	25	17	2031	8	\$1
<b>Fitzgerald Field</b>							
(2) Pumps		1992	30	31	2023	0	\$10,300
Controls	In O & M budget	2018	20	5	2038	15	\$1

\$430,320

# Appendix 3

---



# Appendix 4

---



GRETCHEN WHITMER  
GOVERNOR

STATE OF MICHIGAN  
DEPARTMENT OF  
ENVIRONMENT, GREAT LAKES, AND ENERGY  
LANSING DISTRICT OFFICE



LIESL EICHLER CLARK  
DIRECTOR

March 11, 2021

Violation Notice No. VN-011551

VIA E-MAIL

Mr. David Gutchess, Supervisor  
Wastewater Treatment Plant  
City of Grand Ledge  
109 Fitzgerald Park Drive  
Grand Ledge, Michigan 48837

Dear Mr. Gutchess:

SUBJECT: National Pollutant Discharge Elimination System (NPDES)  
NPDES Permit No. MI0020800  
Designated Name: Grand Ledge WWTP  
Violation Notice

The Department of Environment, Great Lakes, and Energy (EGLE), Water Resources Division (WRD), has determined that the Grand Ledge Wastewater Treatment Plant (WWTP) is in violation of Part 31, Water Resources Protection, of the Natural Resources and Environmental Protection Act, 1994 PA 451, as amended (NREPA); MCL 324.3101 et seq., and the Administrative Rules promulgated thereunder, being 2006 AACRS R 323.2101 et seq., as amended; and NPDES Permit No. MI0020800.

The WRD's Lansing District Office was notified on February 20, 2018; March 14, 2019; June 20, 2019; September 9, 2019; December 30, 2019; January 11, 2020; and May 19, 2020, that a discharge of raw or partially-treated sewage had occurred from the Grand Ledge sewer system. The discharge of raw or partially-treated sewage from a sewer system onto land or into the waters of the state is a violation of Part 31 of the NREPA.

The concerns identified in this Violation Notice were previously addressed in Administrative Consent Order (ACO) ACO- SW07-002, issued April 21, 2009. In response to the ACO, the City of Grand Ledge implemented improvements to its collection system to eliminate discharges of Sanitary Sewer Overflows during wet weather. Various improvements to the system included construction of an equalization basin at the WWTP, a thorough cleaning of the interceptor to maximize flow, and raising the bypass elevations at Manhole 95 and the West River Pump Station.

The City of Grand Ledge, WWTP and Collection System Improvements, Project Performance Certification Addendum 2 (dated December 21, 2018), concludes that the terms of ACO-SW07-002 were satisfied because the hydraulic model shows the system can transport

Grand Ledge WWTP  
NPDES Permit No. MI0020800  
Violation Notice No. VN-011551  
March 11, 2021  
Page 2

the 25-year, 24-hour design storm. Despite these improvements, diluted raw sewage discharges continue to occur during periods of wet weather.

The violations identified in this Violation Notice are continuing. The violations identified in this Violation Notice are violations of Part 31 of the NREPA and NPDES Permit No. MI0020800. Grand Ledge WWTP should take immediate action to maintain compliance with the terms and conditions of Part 31 of the NREPA and NPDES Permit No. MI0020800. No written response is required at this time.

If you have any factual information you would like us to consider regarding the violations identified in this Violation Notice, please provide it in a written response.

We anticipate and appreciate your cooperation in resolving this matter. Should you require further information regarding this Violation Notice or you would like to arrange a meeting to discuss it, please contact me at [CampbellS32@Michigan.gov](mailto:CampbellS32@Michigan.gov); 517-243-9939; or EGLE, WRD, Lansing District Office, 525 West Allegan Street, Constitution Hall, 1st Floor South, P.O. Box 30242, Lansing, Michigan 48909-7742.

Sincerely,

A handwritten signature in black ink that reads "Sarah Campbell". The signature is fluid and cursive, with the first name "Sarah" written in a larger, more prominent script than the last name "Campbell".

Sarah Campbell  
Lansing District Office  
Water Resources Division

sc/sea

cc.: Ms. Katelyn Wysocki, EGLE  
Ms. Cheri Meyer, EGLE, WRD  
Mr. Charles Bennett, EGLE, WRD

# Appendix 5

---

**PERMIT NO. MI0020800**

**STATE OF MICHIGAN**  
**DEPARTMENT OF ENVIRONMENT, GREAT LAKES, AND**  
**ENERGY**

**AUTHORIZATION TO DISCHARGE UNDER THE**  
**NATIONAL POLLUTANT DISCHARGE ELIMINATION SYSTEM**

In compliance with the provisions of the federal Clean Water Act (federal Water Pollution Control Act, 33 U.S.C., Section 1251 *et seq.*, as amended); Part 31, Water Resources Protection, of the Natural Resources and Environmental Protection Act, 1994 PA 451, as amended (NREPA); Part 41, Sewerage Systems, of the NREPA; and Michigan Executive Order 2019-06,

**City of Grand Ledge**  
310 Greenwood Street  
Grand Ledge, MI 48837

is authorized to discharge from the **Grand Ledge Wastewater Treatment Plant** located at

109 Fitzgerald Park Drive  
Grand Ledge, MI 48837

designated as **Grand Ledge WWTP**

to the receiving water named the Grand River in accordance with effluent limitations, monitoring requirements, and other conditions set forth in this permit.

This permit is based on a complete application submitted on June 27, 2017.

**This permit takes effect on October 1, 2019.** The provisions of this permit are severable. After notice and opportunity for a hearing, this permit may be modified, suspended, or revoked in whole or in part during its term in accordance with applicable laws and rules. On its effective date, this permit shall supersede National Pollutant Discharge Elimination System (NPDES) Permit No. MI0020800 (expiring October 1, 2017).

This permit and the authorization to discharge shall expire at midnight on **October 1, 2022**. In order to receive authorization to discharge beyond the date of expiration, the permittee shall submit an application that contains such information, forms, and fees as are required by the Michigan Department of Environment, Great Lakes, and Energy (Department) by **April 4, 2022**.

**Issued:** September 30, 2019.

Original signed by Christine Alexander  
Christine Alexander, Manager  
Permits Section  
Water Resources Division

## PERMIT FEE REQUIREMENTS

In accordance with Section 324.3120 of the NREPA, the permittee shall make payment of an annual permit fee to the Department for each October 1 the permit is in effect regardless of occurrence of discharge. The permittee shall submit the fee in response to the Department's annual notice. Payment may be made electronically via the Department's MiWaters system. The MiWaters website is located at <https://miwaters.deq.state.mi.us>. Payment shall be submitted or postmarked by January 15 for notices mailed by December 1. Payment shall be submitted or postmarked no later than 45 days after receiving the notice for notices mailed after December 1.

**Annual Permit Fee Classification:** Municipal Major, less than 10 MGD (Individual Permit)

In accordance with Section 324.3132 of the NREPA, the permittee shall make payment of an annual biosolids land application fee to the Department if the permittee land applies biosolids. The permittee shall submit the fee in response to the Department's annual notice. Payment may be made electronically via the Department's MiWaters system. The MiWaters website is located at <https://miwaters.deq.state.mi.us>. Payment shall be submitted or postmarked no later than January 31 of each year for notices mailed by December 15. Payment shall be submitted or postmarked no later than 45 days after receiving the notice for notices mailed after December 15.

## CONTACT INFORMATION

Unless specified otherwise, all contact with the Department required by this permit shall be made to the Lansing District Office of the Water Resources Division. The Lansing District Office is located at 525 West Allegan Street, 1st Floor, South Tower, Lansing, MI 48933, Telephone: 517-284-6651, Fax: 517-241-3571.

## CONTESTED CASE INFORMATION

Any person who is aggrieved by this permit may file a sworn petition with the Michigan Administrative Hearing System within the Michigan Department of Licensing and Regulatory Affairs, c/o the Michigan Department of Environment, Great Lakes, and Energy, setting forth the conditions of the permit which are being challenged and specifying the grounds for the challenge. The Department of Licensing and Regulatory Affairs may reject any petition filed more than 60 days after issuance as being untimely.

PART I

Section A. Limitations and Monitoring Requirements

1. Final Effluent Limitations, Monitoring Point 001A

During the period beginning on the effective date of this permit and lasting until the expiration date of this permit, the permittee is authorized to discharge treated municipal wastewater from Monitoring Point 001A through Outfall 001. Outfall 001 discharges to the Grand River at Latitude 42.76228, Longitude -84.76131. Such discharge shall be limited and monitored by the permittee as specified below.

Parameter	Maximum Limits for Quantity or Loading				Maximum Limits for Quality or Concentration				Monitoring Frequency	Sample Type
	Monthly	7-Day	Daily	Units	Monthly	7-Day	Daily	Units		
Flow	(report)	---	(report)	MGD	---	---	---	---	Daily	Report Total Daily Flow
Carbonaceous Biochemical Oxygen Demand (CBOD5)										
	310	500	(report)	lbs/day	25	40	(report)	mg/l	5×Weekly	24-Hr Composite
Total Suspended Solids (TSS)	380	560	(report)	lbs/day	30	45	(report)	mg/l	5×Weekly	24-Hr Composite
Ammonia Nitrogen (as N)	---	---	---	---	(report)	---	(report)	mg/l	5×Weekly	24-Hr Composite
Total Phosphorus (as P)	12	---	(report)	lbs/day	1.0	---	(report)	mg/l	5×Weekly	24-Hr Composite
Fecal Coliform Bacteria	---	---	---	---	200	400	(report)	cts/100 ml	Daily	Grab
Total Residual Chlorine	---	---	---	---	---	---	38	ug/l	Daily	Grab
Total Mercury										
Corrected	(report)	---	(report)	lbs/day	(report)	---	(report)	ng/l	Quarterly	Calculation
Uncorrected	---	---	---	---	---	---	(report)	ng/l	Quarterly	Grab
Field Duplicate	---	---	---	---	---	---	(report)	ng/l	Quarterly	Grab
Field Blank	---	---	---	---	---	---	(report)	ng/l	Quarterly	Preparation
Laboratory Method Blank	---	---	---	---	---	---	(report)	ng/l	Quarterly	Preparation
	<b>12-Month Rolling Avg</b>				<b>12-Month Rolling Avg</b>					
Total Mercury	0.000037	---	---	lbs/day	3.0	---	---	ng/l	Quarterly	Calculation
					<b>Minimum % Monthly</b>		<b>Minimum % Daily</b>			
CBOD5 Minimum % Removal	---	---	---	---	85	---	(report)	%	Monthly	Calculation
TSS Minimum % Removal	---	---	---	---	85	---	(report)	%	Monthly	Calculation
					<b>Minimum Daily</b>		<b>Maximum Daily</b>			
pH	---	---	---	---	6.5	---	9.0	S.U.	Daily	Grab
Dissolved Oxygen	---	---	---	---	4.0	---	---	mg/l	Daily	Grab

The following design flow was used in determining the above limitations, but is not to be considered a limitation or actual capacity: 1.5 MGD.

**PART I****Section A. Limitations and Monitoring Requirements**

- a. **Narrative Standard**  
The receiving water shall contain no turbidity, color, oil films, floating solids, foams, settleable solids, or deposits as a result of this discharge in unnatural quantities which are or may become injurious to any designated use.
- b. **Sampling Locations**  
Samples for Carbonaceous Biochemical Oxygen Demand (CBOD5), Total Suspended Solids (TSS), Ammonia Nitrogen (as N), and Total Phosphorus (as P) shall be taken prior to disinfection. Samples for Fecal Coliform Bacteria, Total Residual Chlorine, Total Mercury, pH, and Dissolved Oxygen shall be taken after disinfection. The Department may approve alternate sampling locations that are demonstrated by the permittee to be representative of the effluent.
- c. **Quarterly Monitoring**  
Quarterly samples shall be taken during the months of January, April, July, and October. If the facility does not discharge during these months, the permittee shall sample the next discharge occurring during the period in question. If the facility does not discharge during the period in question, a sample is not required for that period. For any month in which a sample is not taken, the permittee shall enter "\*"G" on the Discharge Monitoring Report (DMR). (For purposes of reporting on the Daily tab of the DMR, the permittee shall enter "\*"G" on the first day of the month only).
- d. **Total Residual Chlorine (TRC)**  
Compliance with the TRC limit shall be determined on the basis of one (1) or more grab samples. If more than one (1) sample per day is taken, the additional samples shall be collected in near equal intervals over at least eight (8) hours. The samples shall be analyzed immediately upon collection and the average reported as the daily concentration. Samples shall be analyzed in accordance with Part II.B.2. of this permit.
- e. **Percent Removal Requirements**  
Monthly percent removal shall be calculated based on the monthly average effluent CBOD5 and TSS concentrations and the monthly average influent concentrations for approximately the same period. Daily percent removal shall be calculated based on the daily effluent CBOD5 and TSS concentrations and the daily influent concentrations for the same day. Reporting of Daily percent removal is only required on days on which an influent sample is obtained.
- f. **Final Effluent Limitation for Total Mercury**  
The final limit for total mercury is the Discharge Specific Level Currently Achievable (LCA) based on a multiple discharger variance from the WQBEL of 1.3 ng/l, pursuant to Rule 1103(9) of the Water Quality Standards. Compliance with the LCA shall be determined as a 12-month rolling average, the calculation of which may be done using blank-corrected sample results. The 12-month rolling average shall be determined by adding the present monthly average result to the preceding 11 monthly average results then dividing the sum by 12. For facilities with quarterly monitoring requirements for total mercury, quarterly monitoring shall be equivalent to three (3) months of monitoring in calculating the 12-month rolling average. Facilities that monitor more frequently than monthly for total mercury must determine the monthly average result, which is the sum of the results of all data obtained in a given month divided by the total number of samples taken, in order to calculate the 12-month rolling average. If the 12-month rolling average for any quarter is less than or equal to the LCA, the permittee will be considered to be in compliance for total mercury for that quarter, provided the permittee is also in full compliance with the Pollutant Minimization Program for Total Mercury, set forth in Part I.A.4. of this permit.

After a minimum of 10 quarterly data points have been collected, the permittee may request a reduction in the monitoring frequency for total mercury. This request shall contain an explanation as to why the reduced monitoring is appropriate and shall be submitted to the Department. Upon receipt of written approval and consistent with such approval, the permittee may reduce the monitoring frequency for total mercury indicated in Part I.A.1. of this permit. The monitoring frequency shall not be reduced to less than annually. The Department may revoke the approval for reduced monitoring at any time upon notification to the permittee.

**PART I****Section A. Limitations and Monitoring Requirements**

## g. Total Mercury Testing and Additional Reporting Requirements

The analytical protocol for total mercury shall be in accordance with EPA Method 1631, Revision E, "Mercury in Water by Oxidation, Purge and Trap, and Cold Vapor Atomic Fluorescence Spectrometry," EPA-821-R-02-019, August 2002. The quantification level for total mercury shall be 0.5 ng/l, unless a higher level is appropriate because of sample matrix interference. Justification for higher quantification levels shall be submitted to the Department within 30 days of such determination.

The use of clean technique sampling procedures is required unless the permittee can demonstrate to the Department that an alternate sampling procedure is representative of the discharge. Guidance for clean technique sampling is contained in EPA Method 1669, "Sampling Ambient Water for Trace Metals at EPA Water Quality Criteria Levels (Sampling Guidance)," EPA-821-R96-001, July 1996. Information and data documenting the permittee's sampling and analytical protocols and data acceptability shall be submitted to the Department upon request.

In order to demonstrate compliance with EPA Method 1631E and EPA Method 1669, the permittee shall report, on the daily sheet, the analytical results of all field blanks and field duplicates collected in conjunction with each sampling event, as well as laboratory method blanks when used for blank correction. The permittee shall collect at least one (1) field blank and at least one (1) field duplicate per sampling event. If more than ten (10) samples are collected during a sampling event, the permittee shall collect at least one (1) additional field blank AND field duplicate for every ten (10) samples collected. Only field blanks or laboratory method blanks may be used to calculate a concentration lower than the actual sample analytical results (i.e., a blank correction). Only one (1) blank (field OR laboratory method) may be used for blank correction of a given sample result, and only if the blank meets the quality control acceptance criteria. If blank correction is not performed on a given sample analytical result, the permittee shall report under "Total Mercury – Corrected" the same value reported under "Total Mercury – Uncorrected." The field duplicate is for quality control purposes only; its analytical result shall not be averaged with the sample result.

## PART I

## Section A. Limitations and Monitoring Requirements

## 2. Quantification Levels and Analytical Methods for Selected Parameters

Quantification levels (QLs) are specified for selected parameters in the table below. These QLs shall be considered the maximum acceptable unless a higher QL is appropriate because of sample matrix interference. Justification for higher QLs shall be submitted to the Department within 30 days of such determination. Where necessary to help ensure that the QLs specified can be achieved, analytical methods may also be specified in the table below. The sampling procedures, preservation and handling, and analytical protocol for all monitoring conducted in compliance with this permit, including monitoring conducted to meet the requirements of the application for permit reissuance, shall be in accordance with the methods specified in the table below, or in accordance with Part II.B.2. of this permit if no method is specified in the table below, unless an alternate method is approved by the Department. **Not all QLs are expressed in the same units in the table below.** The table is continued on the following page:

Parameter	QL	Units	Analytical Method
1,2-Diphenylhydrazine (as Azobenzene)	3.0	ug/l	
2,4,6-Trichlorophenol	5.0	ug/l	
2,4-Dinitrophenol	19	ug/l	
3,3'-Dichlorobenzidine	1.5	ug/l	EPA Method 605
4-Chloro-3-Methylphenol	7.0	ug/l	
4,4'-DDD	0.05	ug/l	EPA Method 608
4,4'-DDE	0.01	ug/l	EPA Method 608
4,4'-DDT	0.01	ug/l	EPA Method 608
Acrylonitrile	1.0	ug/l	
Aldrin	0.01	ug/l	EPA Method 608
Alpha-Endosulfan	0.01	ug/l	EPA Method 608
Alpha-Hexachlorocyclohexane	0.01	ug/l	EPA Method 608
Antimony, Total	1	ug/l	
Arsenic, Total	1	ug/l	
Barium, Total	5	ug/l	
Benzidine	0.1	ug/l	EPA Method 605
Beryllium, Total	1	ug/l	
Beta-Endosulfan	0.01	ug/l	EPA Method 608
Beta-Hexachlorocyclohexane	0.01	ug/l	EPA Method 608
Bis (2-Chloroethyl) Ether	1.0	ug/l	
Bis (2-Ethylhexyl) Phthalate	5.0	ug/l	
Boron, Total	20	ug/l	
Cadmium, Total	0.2	ug/l	
Chlordane	0.01	ug/l	EPA Method 608
Chloride	1.0	mg/l	
Chromium, Hexavalent	5	ug/l	
Chromium, Total	10	ug/l	
Copper, Total	1	ug/l	
Cyanide, Available	2	ug/l	EPA Method OIA 1677
Cyanide, Total	5	ug/l	
Delta-Hexachlorocyclohexane	0.01	ug/l	EPA Method 608
Dieldrin	0.01	ug/l	EPA Method 608
Di-N-Butyl Phthalate	9.0	ug/l	
Endosulfan Sulfate	0.01	ug/l	EPA Method 608
Endrin	0.01	ug/l	EPA Method 608

## PART I

## Section A. Limitations and Monitoring Requirements

Parameter	QL	Units	Analytical Method
Endrin Aldehyde	0.01	ug/l	EPA Method 608
Fluoranthene	1.0	ug/l	
Heptachlor	0.01	ug/l	EPA Method 608
Heptachlor Epoxide	0.01	ug/l	EPA Method 608
Hexachlorobenzene	0.01	ug/l	EPA Method 612
Hexachlorobutadiene	0.01	ug/l	EPA Method 612
Hexachlorocyclopentadiene	0.01	ug/l	EPA Method 612
Hexachloroethane	5.0	ug/l	
Lead, Total	1	ug/l	
Lindane	0.01	ug/l	EPA Method 608
Lithium, Total	10	ug/l	
Mercury, Total	0.5	ng/l	EPA Method 1631E
Nickel, Total	5	ug/l	
PCB-1016	0.1	ug/l	EPA Method 608
PCB-1221	0.1	ug/l	EPA Method 608
PCB-1232	0.1	ug/l	EPA Method 608
PCB-1242	0.1	ug/l	EPA Method 608
PCB-1248	0.1	ug/l	EPA Method 608
PCB-1254	0.1	ug/l	EPA Method 608
PCB-1260	0.1	ug/l	EPA Method 608
Pentachlorophenol	1.8	ug/l	
Perfluorooctane sulfonate (PFOS)	2.0	ng/l	ASTM D7979 or an isotope dilution method (sometimes referred to as Method 537 modified)
Perfluorooctanoic acid (PFOA)	0.002	ug/l	ASTM D7979 or an isotope dilution method (sometimes referred to as Method 537 modified)
Phenanthrene	1.0	ug/l	
Phosphorus (as P), Total	10	ug/l	
Selenium, Total	1.0	ug/l	
Silver, Total	0.5	ug/l	
Strontium, Total	1000	ug/l	
Sulfate	2.0	mg/l	
Sulfides, Dissolved	20	ug/l	
Thallium, Total	1	ug/l	
Toxaphene	0.1	ug/l	EPA Method 608
Vinyl Chloride	1.0	ug/l	
Zinc, Total	10	ug/l	



**PART I****Section A. Limitations and Monitoring Requirements**Base/Neutral Compounds

acenaphthene	acenaphthylene	anthracene	benzidine
benzo(a)anthracene	benzo(a)pyrene	3,4-benzofluoranthene	benzo(ghi)perylene
benzo(k)fluoranthene	bis(2-chloroethoxy)methane	bis(2-chloroethyl)ether	bis(2-chloroisopropyl)ether
bis(2-ethylhexyl)phthalate	4-bromophenyl phenyl ether	butyl benzyl phthalate	2-chloronaphthalene
4-chlorophenyl phenyl ether	chrysene	di-n-butyl phthalate	di-n-octyl phthalate
dibenzo(a,h)anthracene	1,2-dichlorobenzene	1,3-dichlorobenzene	1,4-dichlorobenzene
3,3'-dichlorobenzidine	diethyl phthalate	dimethyl phthalate	2,4-dinitrotoluene
2,6-dinitrotoluene	1,2-diphenylhydrazine	fluoranthene	fluorene
Hexachlorobenzene	hexachlorobutadiene	hexachlorocyclo-pentadiene	hexachloroethane
indeno(1,2,3-cd)pyrene	isophorone	naphthalene	nitrobenzene
n-nitrosodi-n-propylamine	n-nitrosodimethylamine	n-nitrosodiphenylamine	phenanthrene
pyrene	1,2,4-trichlorobenzene		

**4. Pollutant Minimization Program for Total Mercury**

The goal of the Pollutant Minimization Program is to maintain the effluent concentration of total mercury at or below 1.3 ng/l. The permittee shall continue to implement the Pollutant Minimization Program approved on July 16, 2009, and modifications thereto, to proceed toward the goal. The Pollutant Minimization Program includes the following:

- a. an annual review and semi-annual monitoring of potential sources of mercury entering the wastewater collection system;
- b. a program for quarterly monitoring of influent and periodic monitoring of sludge for mercury; and
- c. implementation of reasonable cost-effective control measures when sources of mercury are discovered. Factors to be considered include significance of sources, economic considerations, and technical and treatability considerations.

On or before March 31 of each year, the permittee shall submit a status report for the previous calendar year to the Department that includes 1) the monitoring results for the previous year, 2) an updated list of potential mercury sources, and 3) a summary of all actions taken to reduce or eliminate identified sources of mercury.

Any information generated as a result of the Pollutant Minimization Program set forth in this permit may be used to support a request to modify the approved program or to demonstrate that the Pollutant Minimization Program requirement has been completed satisfactorily.

A request for modification of the approved program and supporting documentation shall be submitted in writing to the Department for review and approval. The Department may approve modifications to the approved program (approval of a program modification does not require a permit modification), including a reduction in the frequency of the requirements under items a. and b. above.

This permit may be modified in accordance with applicable laws and rules to include additional mercury conditions and/or limitations as necessary.

**PART I****Section A. Limitations and Monitoring Requirements****5. Untreated or Partially Treated Sewage Discharge Reporting and Testing Requirements**

In accordance with Section 324.3112a of the NREPA, if untreated or partially treated sewage is directly or indirectly discharged from a sewer system onto land or into the waters of the state, the permittee shall immediately, but not more than 24 hours after the discharge begins, notify local health departments, a daily newspaper of general circulation in the county in which the permittee is located, and a daily newspaper of general circulation in the county or counties in which the municipalities whose waters may be affected by the discharge are located, that the discharge is occurring. The permittee shall also notify the Department via its MiWaters system on the form entitled "Report of Discharge (CSO\SSO\RTB)." The MiWaters website is located at <https://miwaters.deq.state.mi.us>. At the conclusion of the discharge, the permittee shall make all such notifications specified in, and in accordance with, Section 324.3112a of the NREPA, and shall notify the Department via its MiWaters system on the form entitled "Report of Discharge (CSO\SSO\RTB)."

The permittee shall also annually contact municipalities, including the superintendent of a public drinking water supply with potentially affected intakes, whose waters may be affected by the permittee's discharge of untreated or partially treated sewage, and if those municipalities wish to be notified in the same manner as specified above, the permittee shall provide such notification.

Additionally, in accordance with Section 324.3112a of the NREPA, each time a discharge of untreated or partially treated sewage occurs, the permittee shall test the affected waters for *Escherichia coli* to assess the risk to the public health as a result of the discharge and shall provide the test results to the affected local county health departments and to the Department. The results of this testing shall be submitted to the Department via MiWaters as part of the notification specified above, or, if the results are not yet available, submitted as soon as they become available. This testing is not required if it has been waived by the local health department, or if the discharge(s) did not affect surface waters. The testing shall be done at locations specified by each affected local county health department but shall not exceed 10 tests for each separate discharge event. The affected local county health department may waive this testing requirement if it determines that such testing is not needed to assess the risk to the public health as a result of the discharge event.

Permittees accepting sanitary or municipal sewage from other sewage collection systems are encouraged to notify the owners of those systems of the above reporting and testing requirements.

**6. Facility Contact**

The "Facility Contact" was specified in the application. The permittee may replace the facility contact at any time, and shall notify the Department in writing within 10 days after replacement (including the name, address and telephone number of the new facility contact).

- a. The facility contact shall be (or a duly authorized representative of this person):
  - for a corporation, a principal executive officer of at least the level of vice president; or a designated representative if the representative is responsible for the overall operation of the facility from which the discharge originates, as described in the permit application or other NPDES form,
  - for a partnership, a general partner,
  - for a sole proprietorship, the proprietor, or
  - for a municipal, state, or other public facility, either a principal executive officer, the mayor, village president, city or village manager or other duly authorized employee.

**PART I****Section A. Limitations and Monitoring Requirements**

- b. A person is a duly authorized representative only if:
- the authorization is made in writing to the Department by a person described in paragraph a. of this section; and
  - the authorization specifies either an individual or a position having responsibility for the overall operation of the regulated facility or activity such as the position of plant manager, operator of a well or a well field, superintendent, position of equivalent responsibility, or an individual or position having overall responsibility for environmental matters for the facility (a duly authorized representative may thus be either a named individual or any individual occupying a named position).

Nothing in this section releases the permittee from properly submitting reports and forms as required by law.

**7. Monthly Operating Reports**

Part 41 of Act 451 of 1994 as amended, specifically Section 324.4106 and associated R 299.2953, requires that the permittee file with the Department, on forms prescribed by the Department, operating reports showing the effectiveness of the treatment facility operation and the quantity and quality of liquid wastes discharged into waters of the state.

Within 30 days of the effective date of this permit, the permittee shall submit to the Department a revised treatment facility monitoring program to address monitoring requirement changes reflected in this permit, or submit justification explaining why monitoring requirement changes reflected in this permit do not necessitate revisions to the treatment facility monitoring program. The permittee shall implement the revised treatment facility monitoring program upon approval from the Department. Applicable forms and guidance are available on the Department's web site at [https://www.michigan.gov/egle/0,9429,7-135-3313\\_71618\\_44117---,00.html](https://www.michigan.gov/egle/0,9429,7-135-3313_71618_44117---,00.html). The permittee may use alternate forms if they are consistent with the approved treatment facility monitoring program. Unless the Department provides written notification to the permittee that monthly submittal of operating reports is required, operating reports that result from implementation of the approved treatment facility monitoring program shall be maintained on site for a minimum of three (3) years and shall be made available to the Department for review upon request.

**8. Asset Management**

The permittee shall at all times properly operate and maintain all facilities (i.e., the sewer system and treatment works as defined in Part 41 of the NREPA), and control systems installed or used by the permittee to operate the sewer system and treatment works and achieve and maintain compliance with the conditions of this permit (also see Part II.D.3 of this permit). The requirements of an Asset Management Program function to achieve the goals of effective performance, adequate funding, and adequate operator staffing and training. Asset management is a planning process for ensuring that optimum value is gained for each asset and that financial resources are available to rehabilitate and replace those assets when necessary. Asset management is centered on a framework of five (5) core elements: the current state of the assets; the required sustainable level of service; the assets critical to sustained performance; the minimum life-cycle costs; and the best long-term funding strategy.

- a. **Asset Management Program Requirements**  
On or before April 1, 2020, the permittee shall submit to the Department an Asset Management Plan for review and approval. An approvable Asset Management Plan shall contain a schedule for the development and implementation of an Asset Management Program that meets the requirements outlined below in 1) – 4). A copy of any Asset Management Program requirements already completed by the permittee should be submitted as part of the Asset Management Plan. Upon approval by the Department the permittee shall implement the Asset Management Plan. (The permittee may choose to include the Operation and Maintenance Manual required under Part II.C.14. of this permit as part of their Asset Management Program).

## PART I

## Section A. Limitations and Monitoring Requirements

- 1) *Maintenance Staff.* The permittee shall provide an adequate staff to carry out the operation, maintenance, repair, and testing functions required to ensure compliance with the terms and conditions of this permit. The level of staffing needed shall be determined by taking into account the work involved in operating the sewer system and treatment works, planning for and conducting maintenance, and complying with this permit.
- 2) *Collection System Map.* The permittee shall complete a map of the sewer collection system it owns and operates. The map shall be of sufficient detail and at a scale to allow easy interpretation. The collection system information shown on the map shall be based on current conditions and shall be kept up-to-date and available for review by the Department. **Note: Items below referencing combined sewer systems are not applicable to separate sewer systems.** Such map(s) shall include but not be limited to the following:
  - a) all sanitary sewer lines and related manholes;
  - b) all combined sewer lines, related manholes, catch basins and CSO regulators;
  - c) all known or suspected connections between the sanitary sewer or combined sewer and storm drain systems;
  - d) all outfalls, including the treatment plant outfall(s), combined sewer treatment facility outfalls, untreated CSOs, and any known SSOs;
  - e) all pump stations and force mains;
  - f) the wastewater treatment facility(ies), including all treatment processes;
  - g) all surface waters (labeled);
  - h) other major appurtenances such as inverted siphons and air release valves;
  - i) a numbering system which uniquely identifies manholes, catch basins, overflow points, regulators and outfalls;
  - j) the scale and a north arrow;
  - k) the pipe diameter, date of installation, type of material, distance between manholes, and the direction of flow; and
  - l) the manhole interior material, rim elevation (optional), and invert elevations.
- 3) *Inventory and assessment of fixed assets.* The permittee shall complete an inventory and assessment of operations-related fixed assets including portions of the collection system owned and operated by the permittee. Fixed assets are assets that are normally stationary (e.g., pumps, blowers, buildings, manholes, and sewer lines). The inventory and assessment shall be based on current conditions and shall be kept up-to-date and available for review by the Department.
  - a) The fixed asset inventory shall include the following:
    - (1) a brief description of the fixed asset, its design capacity (e.g., pump: 120 gallons per minute), its level of redundancy, and its tag number if applicable;
    - (2) the location of the fixed asset;
    - (3) the year the fixed asset was installed;
    - (4) the present condition of the fixed asset (e.g., excellent, good, fair, poor); and

**PART I****Section A. Limitations and Monitoring Requirements**

- (5) the current fixed asset (replacement) cost in dollars for year specified in accordance with approved schedules;
- b) The fixed asset assessment shall include a "Business Risk Evaluation" that combines the probability of failure of the fixed asset and the criticality of the fixed asset, as follows:
  - (1) Rate the probability of failure of the fixed asset on a scale of 1-5 (low to high) using criteria such as maintenance history, failure history, and remaining percentage of useful life (or years remaining);
  - (2) Rate the criticality of the fixed asset on a scale of 1-5 (low to high) based on the consequence of failure versus the desired level of service for the facility; and
  - (3) Compute the Business Risk Factor of the fixed asset by multiplying the failure rating from (1) by the criticality rating from (2).
- 4) *Operation, Maintenance & Replacement (OM&R) Budget and Rate Sufficiency for the Sewer System and Treatment Works.* The permittee shall complete an assessment of its user rates and replacement fund, including the following:
  - a) beginning and end dates of fiscal year;
  - b) name of the department, committee, board, or other organization that sets rates for the operation of the sewer system and treatment works;
  - c) amount in the permittee's replacement fund in dollars for year specified in accordance with approved schedules;
  - d) replacement fund strategy of all assets with a useful life of 20 years or less;
  - e) expenditures for maintenance, corrective action and capital improvement taken during the fiscal year;
  - f) OM&R budget for the fiscal year; and
  - g) rate calculation demonstrating sufficient revenues to cover OM&R expenses. If the rate calculation shows there are insufficient revenues to cover OM&R expenses, the permittee shall document, within three (3) fiscal years after submittal of the Asset Management Plan, that there is at least one rate adjustment that reduces the revenue gap by at least 10 percent. The permittee may prepare and submit an alternate plan, subject to Department approval, for addressing the revenue gap. The ultimate goal of the Asset Management Program is to ensure sufficient revenues to cover OM&R expenses.
- b. Annual Reporting  
The permittee shall develop a written report that summarizes asset management activities completed during the previous year and planned for the upcoming year. The written report shall be submitted to the Department on or before September 1 of each year. The written report shall include:
  - 1) a description of the staffing levels maintained during the year;
  - 2) a description of inspections and maintenance activities conducted and corrective actions taken during the previous year;
  - 3) expenditures for collection system maintenance activities, treatment works maintenance activities, corrective actions, and capital improvement during the previous year;

**PART I****Section A. Limitations and Monitoring Requirements**

- 4) a summary of assets/areas identified for inspection/action (including capital improvement) in the upcoming year based on the five (5) core elements and the Business Risk Factors computed in accordance with condition a.3)b)(3) above;
- 5) a maintenance budget and capital improvement budget for the upcoming year that take into account implementation of an effective Asset Management Program that meets the five (5) core elements;
- 6) an updated asset inventory based on the original submission; and
- 7) an updated OM&R budget with an updated rate schedule that includes the amount of insufficient revenues, if any.

**9. Discharge Monitoring Report – Quality Assurance Study Program**

The permittee shall participate in the Discharge Monitoring Report – Quality Assurance (DMR-QA) Study Program. The purpose of the DMR-QA Study Program is to annually evaluate the proficiency of all in-house and/or contract laboratory(ies) that perform, on behalf of the facility authorized to discharge under this permit, the analytical testing required under this permit. In accordance with Section 308 of the Clean Water Act (33 U.S.C. § 1318); and R 323.2138 and R 323.2154 of Part 21, Wastewater Discharge Permits, promulgated under Part 31 of the NREPA, participation in the DMR-QA Study Program is required for all major facilities, and for minor facilities selected for participation by the Department.

Annually and in accordance with DMR-QA Study Program requirements and submittal due dates, the permittee shall submit to the Michigan DMR-QA Study Program state coordinator all documentation required by the DMR-QA Study. DMR-QA Study Program participation is required only for the analytes required under this permit and only when those analytes are also identified in the DMR-QA Study.

If the permitted facility's status as a major facility should change, participation in the DMR-QA Study Program may be reevaluated. Questions concerning participation in the DMR-QA Study Program should be directed to the Michigan DMR-QA Study Program state coordinator.

All forms and instructions required for participation in the DMR-QA Study Program, including submittal due dates and state coordinator contact information, can be found at <http://www.epa.gov/compliance/discharge-monitoring-report-quality-assurance-study-program>.

**PART I**

**Section B. Storm Water Pollution Prevention**

Section B. Storm Water Pollution Prevention is not required for this permit.

**PART I****Section C. Industrial Waste Pretreatment Program****1. Industrial Waste Pretreatment Program**

It is understood that the permittee does not receive the discharge of any type or quantity of substance which may cause interference with the operation of the treatment works; and, therefore, the permittee is not required to immediately develop an industrial pretreatment program in accordance with Section 307 of the Federal Water Pollution Control Act. The permittee is required to comply with Section 307 of the Federal Water Pollution Control Act upon accepting any such discharge for treatment. The permittee is required to notify the Department within thirty (30) days if any user discharges or proposes to discharge such wastes to the permittee for treatment.

Under no circumstances shall the permittee allow introduction of the following wastes into the waste treatment system:

- a. pollutants which cause pass-through or interference;
- b. pollutants which create a fire hazard or explosion hazard in the sewerage system, including, but not limited to waste streams with a closed cup flashpoint of less than 140 degrees Fahrenheit or 60 degrees Centigrade using the test methods specified in 40 CFR 261.21;
- c. pollutants which will cause corrosive structural damage to the sewerage system; but in no case, discharges with pH less than 5.0, unless the works is specifically designed to accommodate such discharges;
- d. solid or viscous pollutants in amounts which will cause obstruction to the flow in the sewerage system resulting in interference;
- e. any pollutant, including oxygen demanding pollutants (BOD, etc.) released in a discharge at a flow rate and/or pollutant concentration which will cause interference with the treatment plant;
- f. heat in amounts which will inhibit biological activity in the treatment plant resulting in interference; but in no case, heat in such quantities that the temperature at the treatment plant exceeds 40 degrees Centigrade (104 degrees Fahrenheit) unless the Department, upon request of the permittee, approves alternate temperature limits;
- g. pollutants which result in the presence of toxic gases, vapors or fumes within the sewerage system in a quantity that may cause acute worker health and safety problems; and
- h. any trucked or hauled pollutants, except at discharge points designated by the permittee.

If information is gained by the Department that the permittee receives or is about to receive industrial wastes, then this permit may be modified in accordance with applicable laws and rules to incorporate the requirements of Section 307 of the Federal Water Pollution Control Act.

**PART I****Section D. Residuals Management Program****1. Residuals Management Program for Land Application of Biosolids**

The permittee is authorized to land-apply bulk biosolids or prepare bulk biosolids for land application in accordance with the permittee's approved Residuals Management Program (RMP) approved on October 5, 2000, and approved modifications thereto, in accordance with the requirements established in R 323.2401 through R 323.2418 of the Michigan Administrative Code (Part 24 Rules). The approved RMP, and any approved modifications thereto, are enforceable requirements of this permit. Incineration, landfilling and other residual disposal activities shall be conducted in accordance with Part II.D.7. of this permit. The Part 24 Rules can be obtained via the internet (<http://www.michigan.gov/egle/> and near the top of the screen click on Water, Wastewater, Surface Water, then click on Biosolids & Industrial Pretreatment, Biosolids, then click on Biosolids Laws and Rules Information which is under the Laws & Rules banner in the center of the screen).

**a. Annual Report**

On or before October 30 of each year, the permittee shall submit an annual report to the Department for the previous fiscal year of October 1 through September 30. The report shall be submitted electronically via the Department's MiWaters system at <https://miwaters.deq.state.mi.us>. At a minimum, the report shall contain:

1) a certification that current residuals management practices are in accordance with the approved RMP, or a proposal for modification to the approved RMP; and

2) a completed Biosolids Annual Report Form, available at <https://miwaters.deq.state.mi.us>.

**b. Modifications to the Approved RMP**

Prior to implementation of modifications to the RMP, the permittee shall submit proposed modifications to the Department for approval. The approved modification shall become effective upon the date of approval. Upon written notification, the Department may impose additional requirements and/or limitations to the approved RMP as necessary to protect public health and the environment from any adverse effect of a pollutant in the biosolids.

**c. Record Keeping**

Records required by the Part 24 Rules shall be kept for a minimum of five years. However, the records documenting cumulative loading for sites subject to cumulative pollutant loading rates shall be kept as long as the site receives biosolids.

**d. Contact Information**

RMP-related submittals shall be made to the Department.

## PART II

Part II may include terms and /or conditions not applicable to discharges covered under this permit.

### Section A. Definitions

**Acute toxic unit (TU<sub>A</sub>)** means  $100/LC_{50}$  where the  $LC_{50}$  is determined from a whole effluent toxicity (WET) test which produces a result that is statistically or graphically estimated to be lethal to 50% of the test organisms.

**Annual monitoring frequency** refers to a calendar year beginning on January 1 and ending on December 31. When required by this permit, an analytical result, reading, value or observation shall be reported for that period if a discharge occurs during that period.

**Authorized public agency** means a state, local, or county agency that is designated pursuant to the provisions of Section 9110 of Part 91, Soil and Sedimentation Control, of the NREPA, to implement soil erosion and sedimentation control requirements with regard to construction activities undertaken by that agency.

**Best management practices (BMPs)** means structural devices or nonstructural practices that are designed to prevent pollutants from entering into storm water, to direct the flow of storm water, or to treat polluted storm water.

**Bioaccumulative chemical of concern (BCC)** means a chemical which, upon entering the surface waters, by itself or as its toxic transformation product, accumulates in aquatic organisms by a human health bioaccumulation factor of more than 1000 after considering metabolism and other physiochemical properties that might enhance or inhibit bioaccumulation. The human health bioaccumulation factor shall be derived according to R 323.1057(5). Chemicals with half-lives of less than 8 weeks in the water column, sediment, and biota are not BCCs. The minimum bioaccumulation concentration factor (BAF) information needed to define an organic chemical as a BCC is either a field-measured BAF or a BAF derived using the biota-sediment accumulation factor (BSAF) methodology. The minimum BAF information needed to define an inorganic chemical as a BCC, including an organometal, is either a field-measured BAF or a laboratory-measured bioconcentration factor (BCF). The BCCs to which these rules apply are identified in Table 5 of R 323.1057 of the Water Quality Standards.

**Biosolids** are the solid, semisolid, or liquid residues generated during the treatment of sanitary sewage or domestic sewage in a treatment works. This includes, but is not limited to, scum or solids removed in primary, secondary, or advanced wastewater treatment processes and a derivative of the removed scum or solids.

**Bulk biosolids** means biosolids that are not sold or given away in a bag or other container for application to a lawn or home garden.

**Certificate of Coverage (COC)** is a document, issued by the Department, which authorizes a discharge under a general permit.

**Chronic toxic unit (TU<sub>C</sub>)** means  $100/MATC$  or  $100/IC_{25}$ , where the maximum acceptable toxicant concentration (MATC) and  $IC_{25}$  are expressed as a percent effluent in the test medium.

**Class B biosolids** refers to material that has met the Class B pathogen reduction requirements or equivalent treatment by a Process to Significantly Reduce Pathogens (PSRP) in accordance with the Part 24 Rules, Land Application of Biosolids, promulgated under Part 31 of the NREPA. Processes include aerobic digestion, composting, anaerobic digestion, lime stabilization and air drying.

**Combined sewer system** is a sewer system in which storm water runoff is combined with sanitary wastes.

## PART II

**Section A. Definitions**

**Daily concentration** is the sum of the concentrations of the individual samples of a parameter divided by the number of samples taken during any calendar day. The daily concentration will be used to determine compliance with any maximum and minimum daily concentration limitations (except for pH and dissolved oxygen). When required by the permit, report the maximum calculated daily concentration for the month in the "MAXIMUM" column under "QUALITY OR CONCENTRATION" on the Discharge Monitoring Reports (DMRs).

For pH, report the maximum value of any *individual* sample taken during the month in the "MAXIMUM" column under "QUALITY OR CONCENTRATION" on the DMRs and the minimum value of any *individual* sample taken during the month in the "MINIMUM" column under "QUALITY OR CONCENTRATION" on the DMRs. For dissolved oxygen, report the minimum concentration of any *individual* sample in the "MINIMUM" column under "QUALITY OR CONCENTRATION" on the DMRs.

**Daily loading** is the total discharge by weight of a parameter discharged during any calendar day. This value is calculated by multiplying the daily concentration by the total daily flow and by the appropriate conversion factor. The daily loading will be used to determine compliance with any maximum daily loading limitations. When required by the permit, report the maximum calculated daily loading for the month in the "MAXIMUM" column under "QUANTITY OR LOADING" on the DMRs.

**Daily monitoring frequency** refers to a 24-hour day. When required by this permit, an analytical result, reading, value or observation shall be reported for that period if a discharge occurs during that period.

**Department** means the Michigan Department of Environment, Great Lakes, and Energy.

**Detection level** means the lowest concentration or amount of the target analyte that can be determined to be different from zero by a single measurement at a stated level of probability.

**Discharge** means the addition of any waste, waste effluent, wastewater, pollutant, or any combination thereof to any surface water of the state.

**EC<sub>50</sub>** means a statistically or graphically estimated concentration that is expected to cause 1 or more specified effects in 50% of a group of organisms under specified conditions.

**Fecal coliform bacteria monthly**

FOR WWSLs THAT COLLECT AND STORE WASTEWATER AND ARE AUTHORIZED TO DISCHARGE ONLY IN THE SPRING AND/OR FALL ON AN INTERMITTENT BASIS – Fecal coliform bacteria monthly is the geometric mean of all daily concentrations determined during a discharge event. Days on which no daily concentration is determined shall not be used to determine the calculated monthly value. The calculated monthly value will be used to determine compliance with the maximum monthly fecal coliform bacteria limitations. When required by the permit, report the calculated monthly value in the "AVERAGE" column under "QUALITY OR CONCENTRATION" on the DMR. If the period in which the discharge event occurred was partially in each of two months, the calculated monthly value shall be reported on the DMR of the month in which the last day of discharge occurred.

FOR ALL OTHER DISCHARGES – Fecal coliform bacteria monthly is the geometric mean of all daily concentrations determined during a reporting month. Days on which no daily concentration is determined shall not be used to determine the calculated monthly value. The calculated monthly value will be used to determine compliance with the maximum monthly fecal coliform bacteria limitations. When required by the permit, report the calculated monthly value in the "AVERAGE" column under "QUALITY OR CONCENTRATION" on the DMR.

**PART II****Section A. Definitions****Fecal coliform bacteria 7-day**

FOR WWSLs THAT COLLECT AND STORE WASTEWATER AND ARE AUTHORIZED TO DISCHARGE ONLY IN THE SPRING AND/OR FALL ON AN INTERMITTENT BASIS – Fecal coliform bacteria 7-day is the geometric mean of the daily concentrations determined during any 7 consecutive days of discharge during a discharge event. If the number of daily concentrations determined during the discharge event is less than 7 days, the number of actual daily concentrations determined shall be used for the calculation. Days on which no daily concentration is determined shall not be used to determine the value. The calculated 7-day value will be used to determine compliance with the maximum 7-day fecal coliform bacteria limitations. When required by the permit, report the maximum calculated 7-day geometric mean value for the month in the “MAXIMUM” column under “QUALITY OR CONCENTRATION” on the DMRs. If the 7-day period was partially in each of two months, the value shall be reported on the DMR of the month in which the last day of discharge occurred.

FOR ALL OTHER DISCHARGES – Fecal coliform bacteria 7-day is the geometric mean of the daily concentrations determined during any 7 consecutive days in a reporting month. If the number of daily concentrations determined is less than 7, the actual number of daily concentrations determined shall be used for the calculation. Days on which no daily concentration is determined shall not be used to determine the value. The calculated 7-day value will be used to determine compliance with the maximum 7-day fecal coliform bacteria limitations. When required by the permit, report the maximum calculated 7-day geometric mean for the month in the “MAXIMUM” column under “QUALITY OR CONCENTRATION” on the DMRs. The first calculation shall be made on day 7 of the reporting month, and the last calculation shall be made on the last day of the reporting month.

**Flow-proportioned sample** is a composite sample with the sample volume proportional to the effluent flow.

**General permit** means an NPDES permit issued authorizing a category of similar discharges.

**Geometric mean** is the average of the logarithmic values of a base 10 data set, converted back to a base 10 number.

**Grab sample** is a single sample taken at neither a set time nor flow.

**IC<sub>25</sub>** means the toxicant concentration that would cause a 25% reduction in a nonquantal biological measurement for the test population.

**Illicit connection** means a physical connection to a municipal separate storm sewer system that primarily conveys non-storm water discharges other than uncontaminated groundwater into the storm sewer; or a physical connection not authorized or permitted by the local authority, where a local authority requires authorization or a permit for physical connections.

**Illicit discharge** means any discharge to, or seepage into, a municipal separate storm sewer system that is not composed entirely of storm water or uncontaminated groundwater. Illicit discharges include non-storm water discharges through pipes or other physical connections; dumping of motor vehicle fluids, household hazardous wastes, domestic animal wastes, or litter; collection and intentional dumping of grass clippings or leaf litter; or unauthorized discharges of sewage, industrial waste, restaurant wastes, or any other non-storm water waste directly into a separate storm sewer.

**Individual permit** means a site-specific NPDES permit.

**Inlet** means a catch basin, roof drain, conduit, drain tile, retention pond riser pipe, sump pump, or other point where storm water or wastewater enters into a closed conveyance system prior to discharge off site or into waters of the state.

**PART II****Section A. Definitions**

**Interference** is a discharge which, alone or in conjunction with a discharge or discharges from other sources, both: 1) inhibits or disrupts a POTW, its treatment processes or operations, or its sludge processes, use or disposal; and 2) therefore, is a cause of a violation of any requirement of the POTW's NPDES permit (including an increase in the magnitude or duration of a violation) or, of the prevention of sewage sludge use or disposal in compliance with the following statutory provisions and regulations or permits issued thereunder (or more stringent state or local regulations): Section 405 of the Clean Water Act, the Solid Waste Disposal Act (SWDA) (including Title II, more commonly referred to as the Resource Conservation and Recovery Act (RCRA), and including state regulations contained in any state sludge management plan prepared pursuant to Subtitle D of the SWDA), the Clean Air Act, the Toxic Substances Control Act, and the Marine Protection, Research and Sanctuaries Act. [This definition does not apply to sample matrix interference].

**Land application** means spraying or spreading biosolids or a biosolids derivative onto the land surface, injecting below the land surface, or incorporating into the soil so that the biosolids or biosolids derivative can either condition the soil or fertilize crops or vegetation grown in the soil.

**LC<sub>50</sub>** means a statistically or graphically estimated concentration that is expected to be lethal to 50% of a group of organisms under specified conditions.

**Maximum acceptable toxicant concentration (MATC)** means the concentration obtained by calculating the geometric mean of the lower and upper chronic limits from a chronic test. A lower chronic limit is the highest tested concentration that did not cause the occurrence of a specific adverse effect. An upper chronic limit is the lowest tested concentration which did cause the occurrence of a specific adverse effect and above which all tested concentrations caused such an occurrence.

**Maximum extent practicable** means implementation of best management practices by a public body to comply with an approved storm water management program as required by a national permit for a municipal separate storm sewer system, in a manner that is environmentally beneficial, technically feasible, and within the public body's legal authority.

**MBTU/hr** means million British Thermal Units per hour.

**MGD** means million gallons per day.

**Monthly concentration** is the sum of the daily concentrations determined during a reporting period divided by the number of daily concentrations determined. The calculated monthly concentration will be used to determine compliance with any maximum monthly concentration limitations. Days with no discharge shall not be used to determine the value. When required by the permit, report the calculated monthly concentration in the "AVERAGE" column under "QUALITY OR CONCENTRATION" on the DMR.

For minimum percent removal requirements, the monthly influent concentration and the monthly effluent concentration shall be determined. The calculated monthly percent removal, which is equal to 100 times the quantity [1 minus the quantity (monthly effluent concentration divided by the monthly influent concentration)], shall be reported in the "MINIMUM" column under "QUALITY OR CONCENTRATION" on the DMRs.

**Monthly loading** is the sum of the daily loadings of a parameter divided by the number of daily loadings determined during a reporting period. The calculated monthly loading will be used to determine compliance with any maximum monthly loading limitations. Days with no discharge shall not be used to determine the value. When required by the permit, report the calculated monthly loading in the "AVERAGE" column under "QUANTITY OR LOADING" on the DMR.

**Monthly monitoring frequency** refers to a calendar month. When required by this permit, an analytical result, reading, value or observation shall be reported for that period if a discharge occurs during that period.

**Municipal separate storm sewer** means a conveyance or system of conveyances designed or used for collecting or conveying storm water which is not a combined sewer and which is not part of a POTW as defined in the Code of Federal Regulations at 40 CFR 122.2.

## PART II

### Section A. Definitions

**Municipal separate storm sewer system (MS4)** means all separate storm sewers that are owned or operated by the United States, a state, city, village, township, county, district, association, or other public body created by or pursuant to state law, having jurisdiction over disposal of sewage, industrial wastes, storm water, or other wastes, including special districts under state law, such as a sewer district, flood control district, or drainage district, or similar entity, or a designated or approved management agency under Section 208 of the Clean Water Act that discharges to the waters of the state. This term includes systems similar to separate storm sewer systems in municipalities, such as systems at military bases, large hospital or prison complexes, and highways and other thoroughfares. The term does not include separate storm sewers in very discrete areas, such as individual buildings.

**National Pretreatment Standards** are the regulations promulgated by or to be promulgated by the Federal Environmental Protection Agency pursuant to Section 307(b) and (c) of the Clean Water Act. The standards establish nationwide limits for specific industrial categories for discharge to a POTW.

**No observed adverse effect level (NOAEL)** means the highest tested dose or concentration of a substance which results in no observed adverse effect in exposed test organisms where higher doses or concentrations result in an adverse effect.

**Noncontact cooling water** is water used for cooling which does not come into direct contact with any raw material, intermediate product, by-product, waste product or finished product.

**Nondomestic user** is any discharger to a POTW that discharges wastes other than or in addition to water-carried wastes from toilet, kitchen, laundry, bathing or other facilities used for household purposes.

**Nonstructural controls** are practices or procedures implemented by employees at a facility to manage storm water or to prevent contamination of storm water.

**NPDES** means National Pollutant Discharge Elimination System.

**Outfall** is the location at which a point source discharge first enters a surface water of the state.

**Part 91 agency** means an agency that is designated by a county board of commissioners pursuant to the provisions of Section 9105 of Part 91 of the NREPA; an agency that is designated by a city, village, or township in accordance with the provisions of Section 9106 of Part 91 of the NREPA; or the Department for soil erosion and sedimentation control activities under Part 615, Supervisor of Wells; Part 631, Reclamation of Mining Lands; or Part 632, Nonferrous Metallic Mineral Mining, of the NREPA, pursuant to the provisions of Section 9115 of Part 91 of the NREPA.

**Part 91 permit** means a soil erosion and sedimentation control permit issued by a Part 91 agency pursuant to the provisions of Part 91 of the NREPA.

**Partially treated sewage** is any sewage, sewage and storm water, or sewage and wastewater, from domestic or industrial sources that is treated to a level less than that required by the permittee's NPDES permit, or that is not treated to national secondary treatment standards for wastewater, including discharges to surface waters from retention treatment facilities.

**Point of discharge** is the location of a point source discharge where storm water is discharged directly into a separate storm sewer system.

**Point source discharge** means a discharge from any discernible, confined, discrete conveyance, including but not limited to any pipe, ditch, channel, tunnel, conduit, well, discrete fissure, container, or rolling stock. Changing the surface of land or establishing grading patterns on land will result in a point source discharge where the runoff from the site is ultimately discharged to waters of the state.

**Polluting material** means any material, in solid or liquid form, identified as a polluting material under the Part 5 Rules, Spillage of Oil and Polluting Materials, promulgated under Part 31 of the NREPA (R 324.2001 through R 324.2009 of the Michigan Administrative Code).

**PART II****Section A. Definitions**

**POTW** is a publicly owned treatment work.

**Pretreatment** is reducing the amount of pollutants, eliminating pollutants, or altering the nature of pollutant properties to a less harmful state prior to discharge into a public sewer. The reduction or alteration can be by physical, chemical, or biological processes, process changes, or by other means. Dilution is not considered pretreatment unless expressly authorized by an applicable National Pretreatment Standard for a particular industrial category.

**Public** (as used in the MS4 individual permit) means all persons who potentially could affect the authorized storm water discharges, including, but not limited to, residents, visitors to the area, public employees, businesses, industries, and construction contractors and developers.

**Public body** means the United States; the state of Michigan; a city, village, township, county, school district, public college or university, or single-purpose governmental agency; or any other body which is created by federal or state statute or law.

**Qualified Personnel** means an individual who meets qualifications acceptable to the Department and who is authorized by an Industrial Storm Water Certified Operator to collect the storm water sample.

**Qualifying storm event** means a storm event causing greater than 0.1 inch of rainfall and occurring at least 72 hours after the previous measurable storm event that also caused greater than 0.1 inch of rainfall. Upon request, the Department may approve an alternate definition meeting the condition of a qualifying storm event.

**Quantification level** means the measurement of the concentration of a contaminant obtained by using a specified laboratory procedure calculated at a specified concentration above the detection level. It is considered the lowest concentration at which a particular contaminant can be quantitatively measured using a specified laboratory procedure for monitoring of the contaminant.

**Quarterly monitoring frequency** refers to a three month period, defined as January through March, April through June, July through September, and October through December. When required by this permit, an analytical result, reading, value or observation shall be reported for that period if a discharge occurs during that period.

**Regional Administrator** is the Region 5 Administrator, U.S. EPA, located at R-19J, 77 W. Jackson Blvd., Chicago, Illinois 60604.

**Regulated area** means the permittee's urbanized area, where urbanized area is defined as a place and its adjacent densely-populated territory that together have a minimum population of 50,000 people as defined by the United States Bureau of the Census and as determined by the latest available decennial census.

**Secondary containment structure** means a unit, other than the primary container, in which significant materials are packaged or held, which is required by state or federal law to prevent the escape of significant materials by gravity into sewers, drains, or otherwise directly or indirectly into any sewer system or to the surface waters or groundwaters of the state.

**Separate storm sewer system** means a system of drainage, including, but not limited to, roads, catch basins, curbs, gutters, parking lots, ditches, conduits, pumping devices, or man-made channels, which is not a combined sewer where storm water mixes with sanitary wastes, and is not part of a POTW.

**Significant industrial user** is a nondomestic user that: 1) is subject to Categorical Pretreatment Standards under 40 CFR 403.6 and 40 CFR Chapter I, Subchapter N; or 2) discharges an average of 25,000 gallons per day or more of process wastewater to a POTW (excluding sanitary, noncontact cooling and boiler blowdown wastewater); contributes a process waste stream which makes up five (5) percent or more of the average dry weather hydraulic or organic capacity of the POTW treatment plant; or is designated as such by the permittee as defined in 40 CFR 403.12(a) on the basis that the industrial user has a reasonable potential for adversely affecting the POTW's treatment plant operation or violating any pretreatment standard or requirement (in accordance with 40 CFR 403.8(f)(6)).

**PART II****Section A. Definitions**

**Significant materials** means any material which could degrade or impair water quality, including but not limited to: raw materials; fuels; solvents, detergents, and plastic pellets; finished materials such as metallic products; hazardous substances designated under Section 101(14) of the Comprehensive Environmental Response, Compensation, and Liability Act (CERCLA) (see 40 CFR 372.65); any chemical the facility is required to report pursuant to Section 313 of Emergency Planning and Community Right-to-Know Act (EPCRA); polluting materials as identified under the Part 5 Rules (R 324.2001 through R 324.2009 of the Michigan Administrative Code); Hazardous Wastes as defined in Part 111, Hazardous Waste Management, of the NREPA; fertilizers; pesticides; and waste products such as ashes, slag, and sludge that have the potential to be released with storm water discharges.

**Significant spills and significant leaks** means any release of a polluting material reportable under the Part 5 Rules (R 324.2001 through R 324.2009 of the Michigan Administrative Code).

**Special-use area** means storm water discharges for which the Department has determined that additional monitoring is needed from: secondary containment structures required by state or federal law; lands on Michigan's List of Sites of Environmental Contamination pursuant to Part 201, Environmental Remediation, of the NREPA; and/or areas with other activities that may contribute pollutants to the storm water.

**Stoichiometric** means the quantity of a reagent calculated to be necessary and sufficient for a given chemical reaction.

**Storm water** means storm water runoff, snow melt runoff, surface runoff and drainage, and non-storm water included under the conditions of this permit.

**Storm water discharge point** is the location where the point source discharge of storm water is directed to surface waters of the state or to a separate storm sewer. It includes the location of all point source discharges where storm water exits the facility, including *outfalls* which discharge directly to surface waters of the state, and *points of discharge* which discharge directly into separate storm sewer systems.

**Structural controls** are physical features or structures used at a facility to manage or treat storm water.

**SWPPP** means the Storm Water Pollution Prevention Plan prepared in accordance with this permit.

**Tier I value** means a value for aquatic life, human health or wildlife calculated under R 323.1057 of the Water Quality Standards using a tier I toxicity database.

**Tier II value** means a value for aquatic life, human health or wildlife calculated under R 323.1057 of the Water Quality Standards using a tier II toxicity database.

**Total maximum daily loads (TMDLs)** are required by the Clean Water Act for waterbodies that do not meet water quality standards. TMDLs represent the maximum daily load of a pollutant that a waterbody can assimilate and meet water quality standards, and an allocation of that load among point sources, nonpoint sources, and a margin of safety.

**Toxicity reduction evaluation (TRE)** means a site-specific study conducted in a stepwise process designed to identify the causative agents of effluent toxicity, isolate the sources of toxicity, evaluate the effectiveness of toxicity control options, and then confirm the reduction in effluent toxicity.

**Water Quality Standards** means the Part 4 Water Quality Standards promulgated pursuant to Part 31 of the NREPA, being R 323.1041 through R 323.1117 of the Michigan Administrative Code.

**Weekly monitoring frequency** refers to a calendar week which begins on Sunday and ends on Saturday. When required by this permit, an analytical result, reading, value or observation shall be reported for that period if a discharge occurs during that period.

**WWSL** is a wastewater stabilization lagoon.

**PART II****Section A. Definitions**

**WWSL discharge event** is a discrete occurrence during which effluent is discharged to the surface water up to 10 days of a consecutive 14 day period.

**3-portion composite sample** is a sample consisting of three equal-volume grab samples collected at equal intervals over an 8-hour period.

**7-day concentration**

FOR WWSLs THAT COLLECT AND STORE WASTEWATER AND ARE AUTHORIZED TO DISCHARGE ONLY IN THE SPRING AND/OR FALL ON AN INTERMITTENT BASIS – The 7-day concentration is the sum of the daily concentrations determined during any 7 consecutive days of discharge during a WWSL discharge event divided by the number of daily concentrations determined. If the number of daily concentrations determined during the WWSL discharge event is less than 7 days, the number of actual daily concentrations determined shall be used for the calculation. The calculated 7-day concentration will be used to determine compliance with any maximum 7-day concentration limitations. When required by the permit, report the maximum calculated 7-day concentration for the WWSL discharge event in the “MAXIMUM” column under “QUALITY OR CONCENTRATION” on the DMR. If the WWSL discharge event was partially in each of two months, the value shall be reported on the DMR of the month in which the last day of discharge occurred.

FOR ALL OTHER DISCHARGES – The 7-day concentration is the sum of the daily concentrations determined during any 7 consecutive days in a reporting month divided by the number of daily concentrations determined. If the number of daily concentrations determined is less than 7, the actual number of daily concentrations determined shall be used for the calculation. The calculated 7-day concentration will be used to determine compliance with any maximum 7-day concentration limitations in the reporting month. When required by the permit, report the maximum calculated 7-day concentration for the month in the “MAXIMUM” column under “QUALITY OR CONCENTRATION” on the DMR. The first 7-day calculation shall be made on day 7 of the reporting month, and the last calculation shall be made on the last day of the reporting month.

**7-day loading**

FOR WWSLs THAT COLLECT AND STORE WASTEWATER AND ARE AUTHORIZED TO DISCHARGE ONLY IN THE SPRING AND/OR FALL ON AN INTERMITTENT BASIS – The 7-day loading is the sum of the daily loadings determined during any 7 consecutive days of discharge during a WWSL discharge event divided by the number of daily loadings determined. If the number of daily loadings determined during the WWSL discharge event is less than 7 days, the number of actual daily loadings determined shall be used for the calculation. The calculated 7-day loading will be used to determine compliance with any maximum 7-day loading limitations. When required by the permit, report the maximum calculated 7-day loading for the WWSL discharge event in the “MAXIMUM” column under “QUANTITY OR LOADING” on the DMR. If the WWSL discharge event was partially in each of two months, the value shall be reported on the DMR of the month in which the last day of discharge occurred.

FOR ALL OTHER DISCHARGES – The 7-day loading is the sum of the daily loadings determined during any 7 consecutive days in a reporting month divided by the number of daily loadings determined. If the number of daily loadings determined is less than 7, the actual number of daily loadings determined shall be used for the calculation. The calculated 7-day loading will be used to determine compliance with any maximum 7-day loading limitations in the reporting month. When required by the permit, report the maximum calculated 7-day loading for the month in the “MAXIMUM” column under “QUANTITY OR LOADING” on the DMR. The first 7-day calculation shall be made on day 7 of the reporting month, and the last calculation shall be made on the last day of the reporting month.

**24-hour composite sample** is a flow-proportioned composite sample consisting of hourly or more frequent portions that are taken over a 24-hour period. A time-proportioned composite sample may be used upon approval of the Department if the permittee demonstrates it is representative of the discharge.

**PART II****Section B. Monitoring Procedures****1. Representative Samples**

Samples and measurements taken as required herein shall be representative of the volume and nature of the monitored discharge.

**2. Test Procedures**

Test procedures for the analysis of pollutants shall conform to regulations promulgated pursuant to Section 304(h) of the Clean Water Act (40 CFR Part 136 – Guidelines Establishing Test Procedures for the Analysis of Pollutants), unless specified otherwise in this permit. **Test procedures used shall be sufficiently sensitive to determine compliance with applicable effluent limitations.** Requests to use test procedures not promulgated under 40 CFR Part 136 for pollutant monitoring required by this permit shall be made in accordance with the Alternate Test Procedures regulations specified in 40 CFR 136.4. These requests shall be submitted to the Manager of the Permits Section, Water Resources Division, Michigan Department of Environment, Great Lakes, and Energy, P.O. Box 30458, Lansing, Michigan, 48909-7958. The permittee may use such procedures upon approval.

The permittee shall periodically calibrate and perform maintenance procedures on all analytical instrumentation at intervals to ensure accuracy of measurements. The calibration and maintenance shall be performed as part of the permittee's laboratory Quality Assurance/Quality Control program.

**3. Instrumentation**

The permittee shall periodically calibrate and perform maintenance procedures on all monitoring instrumentation at intervals to ensure accuracy of measurements.

**4. Recording Results**

For each measurement or sample taken pursuant to the requirements of this permit, the permittee shall record the following information: 1) the exact place, date, and time of measurement or sampling; 2) the person(s) who performed the measurement or sample collection; 3) the dates the analyses were performed; 4) the person(s) who performed the analyses; 5) the analytical techniques or methods used; 6) the date of and person responsible for equipment calibration; and 7) the results of all required analyses.

**5. Records Retention**

All records and information resulting from the monitoring activities required by this permit including all records of analyses performed and calibration and maintenance of instrumentation and recordings from continuous monitoring instrumentation shall be retained for a minimum of three (3) years, or longer if requested by the Regional Administrator or the Department.

**PART II****Section C. Reporting Requirements****1. Start-Up Notification**

If the permittee will not discharge during the first 60 days following the effective date of this permit, the permittee shall notify the Department within 14 days following the effective date of this permit, and then 60 days prior to the commencement of the discharge.

**2. Submittal Requirements for Self-Monitoring Data**

Part 31 of the NREPA (specifically Section 324.3110(7)); and R 323.2155(2) of Part 21, Wastewater Discharge Permits, promulgated under Part 31 of the NREPA, allow the Department to specify the forms to be utilized for reporting the required self-monitoring data. Unless instructed on the effluent limitations page to conduct "Retained Self-Monitoring," the permittee shall submit self-monitoring data via the Department's MiWaters system.

The permittee shall utilize the information provided on the MiWaters website, located at <https://miwaters.deq.state.mi.us>, to access and submit the electronic forms. Both monthly summary and daily data shall be submitted to the Department no later than the 20<sup>th</sup> day of the month following each month of the authorized discharge period(s). The permittee may be allowed to submit the electronic forms after this date if the Department has granted an extension to the submittal date.

**3. Retained Self-Monitoring Requirements**

If instructed on the effluent limits page (or otherwise authorized by the Department in accordance with the provisions of this permit) to conduct retained self-monitoring, the permittee shall maintain a year-to-date log of retained self-monitoring results and, upon request, provide such log for inspection to the staff of the Department. Retained self-monitoring results are public information and shall be promptly provided to the public upon request.

The permittee shall certify, in writing, to the Department, on or before January 10<sup>th</sup> (April 1<sup>st</sup> for animal feeding operation facilities) of each year, that: 1) all retained self-monitoring requirements have been complied with and a year-to-date log has been maintained; and 2) the application on which this permit is based still accurately describes the discharge. With this annual certification, the permittee shall submit a summary of the previous year's monitoring data. The summary shall include maximum values for samples to be reported as daily maximums and/or monthly maximums and minimum values for any daily minimum samples.

Retained self-monitoring may be denied to a permittee by notification in writing from the Department. In such cases, the permittee shall submit self-monitoring data in accordance with Part II.C.2., above. Such a denial may be rescinded by the Department upon written notification to the permittee. Reissuance or modification of this permit or reissuance or modification of an individual permittee's authorization to discharge shall not affect previous approval or denial for retained self-monitoring unless the Department provides notification in writing to the permittee.

**4. Additional Monitoring by Permittee**

If the permittee monitors any pollutant at the location(s) designated herein more frequently than required by this permit, using approved analytical methods as specified above, the results of such monitoring shall be included in the calculation and reporting of the values required in the Discharge Monitoring Report. Such increased frequency shall also be indicated.

Monitoring required pursuant to Part 41 of the NREPA or Rule 35 of the Mobile Home Park Commission Act, 1987 PA 96, as amended, for assurance of proper facility operation shall be submitted as required by the Department.

**PART II****Section C. Reporting Requirements****5. Compliance Dates Notification**

Within 14 days of every compliance date specified in this permit, the permittee shall submit a *written* notification to the Department indicating whether or not the particular requirement was accomplished. If the requirement was not accomplished, the notification shall include an explanation of the failure to accomplish the requirement, actions taken or planned by the permittee to correct the situation, and an estimate of when the requirement will be accomplished. If a written report is required to be submitted by a specified date and the permittee accomplishes this, a separate written notification is not required.

**6. Noncompliance Notification**

Compliance with all applicable requirements set forth in the Clean Water Act, Parts 31 and 41 of the NREPA, and related regulations and rules is required. All instances of noncompliance shall be reported as follows:

- a. 24-Hour Reporting  
Any noncompliance which may endanger health or the environment (including maximum and/or minimum daily concentration discharge limitation exceedances) shall be reported, verbally, within 24 hours from the time the permittee becomes aware of the noncompliance. A written submission shall also be provided within five (5) days.
- b. Other Reporting  
The permittee shall report, in writing, all other instances of noncompliance not described in a. above at the time monitoring reports are submitted; or, in the case of retained self-monitoring, within five (5) days from the time the permittee becomes aware of the noncompliance.

Written reporting shall include: 1) a description of the discharge and cause of noncompliance; and 2) the period of noncompliance, including exact dates and times, or, if not yet corrected, the anticipated time the noncompliance is expected to continue, and the steps taken to reduce, eliminate and prevent recurrence of the noncomplying discharge.

**7. Spill Notification**

The permittee shall immediately report any release of any polluting material which occurs to the surface waters or groundwaters of the state, unless the permittee has determined that the release is not in excess of the threshold reporting quantities specified in the Part 5 Rules (R 324.2001 through R 324.2009 of the Michigan Administrative Code), by calling the Department at the number indicated on the second page of this permit (or, if this is a general permit, on the COC); or, if the notice is provided after regular working hours, call the Department's 24-hour Pollution Emergency Alerting System telephone number, 1-800-292-4706 (calls from **out-of-state** call 1-517-373-7660).

Within ten (10) days of the release, the permittee shall submit to the Department a full written explanation as to the cause of the release, the discovery of the release, response (clean-up and/or recovery) measures taken, and preventive measures taken or a schedule for completion of measures to be taken to prevent reoccurrence of similar releases.

**PART II****Section C. Reporting Requirements****8. Upset Noncompliance Notification**

If a process "upset" (defined as an exceptional incident in which there is unintentional and temporary noncompliance with technology based permit effluent limitations because of factors beyond the reasonable control of the permittee) has occurred, the permittee who wishes to establish the affirmative defense of upset, shall notify the Department by telephone within 24 hours of becoming aware of such conditions; and within five (5) days, provide in writing, the following information:

- a. that an upset occurred and that the permittee can identify the specific cause(s) of the upset;
- b. that the permitted wastewater treatment facility was, at the time, being properly operated and maintained (note that an upset does not include noncompliance to the extent caused by operational error, improperly designed treatment facilities, inadequate treatment facilities, lack of preventive maintenance, or careless or improper operation); and
- c. that the permittee has specified and taken action on all responsible steps to minimize or correct any adverse impact in the environment resulting from noncompliance with this permit.

No determination made during administrative review of claims that noncompliance was caused by upset, and before an action for noncompliance, is final administrative action subject to judicial review.

In any enforcement proceedings, the permittee, seeking to establish the occurrence of an upset, has the burden of proof.

**9. Bypass Prohibition and Notification**

- a. **Bypass Prohibition**  
Bypass is prohibited, and the Department may take an enforcement action, unless:
  - 1) bypass was unavoidable to prevent loss of life, personal injury, or severe property damage;
  - 2) there were no feasible alternatives to the bypass, such as the use of auxiliary treatment facilities, retention of untreated wastes, or maintenance during normal periods of equipment downtime. This condition is not satisfied if adequate backup equipment should have been installed in the exercise of reasonable engineering judgment to prevent a bypass; and
  - 3) the permittee submitted notices as required under 9.b. or 9.c. below.
- b. **Notice of Anticipated Bypass**  
If the permittee knows in advance of the need for a bypass, it shall submit prior notice to the Department, if possible at least ten (10) days before the date of the bypass, and provide information about the anticipated bypass as required by the Department. The Department may approve an anticipated bypass, after considering its adverse effects, if it will meet the three (3) conditions listed in 9.a. above.
- c. **Notice of Unanticipated Bypass**  
The permittee shall submit notice to the Department of an unanticipated bypass by calling the Department at the number indicated on the second page of this permit (if the notice is provided after regular working hours, call: 1-800-292-4706) as soon as possible, but no later than 24 hours from the time the permittee becomes aware of the circumstances.

**PART II****Section C. Reporting Requirements**

- d. **Written Report of Bypass**  
A written submission shall be provided within five (5) working days of commencing any bypass to the Department, and at additional times as directed by the Department. The written submission shall contain a description of the bypass and its cause; the period of bypass, including exact dates and times, and if the bypass has not been corrected, the anticipated time it is expected to continue; steps taken or planned to reduce, eliminate, and prevent reoccurrence of the bypass; and other information as required by the Department.
- e. **Bypass Not Exceeding Limitations**  
The permittee may allow any bypass to occur which does not cause effluent limitations to be exceeded, but only if it also is for essential maintenance to ensure efficient operation. These bypasses are not subject to the provisions of 9.a., 9.b., 9.c., and 9.d., above. This provision does not relieve the permittee of any notification responsibilities under Part II.C.11. of this permit.
- f. **Definitions**
- 1) Bypass means the intentional diversion of waste streams from any portion of a treatment facility.
  - 2) Severe property damage means substantial physical damage to property, damage to the treatment facilities which causes them to become inoperable, or substantial and permanent loss of natural resources which can reasonably be expected to occur in the absence of a bypass. Severe property damage does not mean economic loss caused by delays in production.

**10. Bioaccumulative Chemicals of Concern (BCC)**

Consistent with the requirements of R 323.1098 and R 323.1215 of the Michigan Administrative Code, the permittee is prohibited from undertaking any action that would result in a lowering of water quality from an increased loading of a BCC unless an increased use request and antidegradation demonstration have been submitted and approved by the Department.

**11. Notification of Changes in Discharge**

The permittee shall notify the Department, in writing, as soon as possible but no later than 10 days of knowing, or having reason to believe, that any activity or change has occurred or will occur which would result in the discharge of: 1) detectable levels of chemicals on the current Michigan Critical Materials Register, priority pollutants or hazardous substances set forth in 40 CFR 122.21, Appendix D, or the Pollutants of Initial Focus in the Great Lakes Water Quality Initiative specified in 40 CFR 132.6, Table 6, which were not acknowledged in the application or listed in the application at less than detectable levels; 2) detectable levels of any other chemical not listed in the application or listed at less than detection, for which the application specifically requested information; or 3) any chemical at levels greater than five times the average level reported in the complete application (see the first page of this permit, for the date(s) the complete application was submitted). Any other monitoring results obtained as a requirement of this permit shall be reported in accordance with the compliance schedules.

**PART II****Section C. Reporting Requirements****12. Changes in Facility Operations**

Any anticipated action or activity, including but not limited to facility expansion, production increases, or process modification, which will result in new or increased loadings of pollutants to the receiving waters must be reported to the Department by a) submission of an increased use request (application) and all information required under R 323.1098 (Antidegradation) of the Water Quality Standards or b) by notice if the following conditions are met: 1) the action or activity will not result in a change in the types of wastewater discharged or result in a greater quantity of wastewater than currently authorized by this permit; 2) the action or activity will not result in violations of the effluent limitations specified in this permit; 3) the action or activity is not prohibited by the requirements of Part II.C.10.; and 4) the action or activity will not require notification pursuant to Part II.C.11. Following such notice, the permit or, if applicable, the facility's COC may be modified according to applicable laws and rules to specify and limit any pollutant not previously limited.

**13. Transfer of Ownership or Control**

In the event of any change in control or ownership of facilities from which the authorized discharge emanates, the permittee shall submit to the Department 30 days prior to the actual transfer of ownership or control a written agreement between the current permittee and the new permittee containing: 1) the legal name and address of the new owner; 2) a specific date for the effective transfer of permit responsibility, coverage and liability; and 3) a certification of the continuity of or any changes in operations, wastewater discharge, or wastewater treatment.

If the new permittee is proposing changes in operations, wastewater discharge, or wastewater treatment, the Department may propose modification of this permit in accordance with applicable laws and rules.

**14. Operations and Maintenance Manual**

For wastewater treatment facilities that serve the public (and are thus subject to Part 41 of the NREPA), Section 4104 of Part 41 and associated Rule 2957 of the Michigan Administrative Code allow the Department to require an Operations and Maintenance (O&M) Manual from the facility. An up-to-date copy of the O&M Manual shall be kept at the facility and shall be provided to the Department upon request. The Department may review the O&M Manual in whole or in part at its discretion and require modifications to it if portions are determined to be inadequate.

At a minimum, the O&M Manual shall include the following information: permit standards; descriptions and operation information for all equipment; staffing information; laboratory requirements; record keeping requirements; a maintenance plan for equipment; an emergency operating plan; safety program information; and copies of all pertinent forms, as-built plans, and manufacturer's manuals.

Certification of the existence and accuracy of the O&M Manual shall be submitted to the Department at least sixty days prior to start-up of a new wastewater treatment facility. Recertification shall be submitted sixty days prior to start-up of any substantial improvements or modifications made to an existing wastewater treatment facility.

**PART II****Section C. Reporting Requirements****15. Signatory Requirements**

All applications, reports, or information submitted to the Department in accordance with the conditions of this permit and that require a signature shall be signed and certified as described in the Clean Water Act and the NREPA.

The Clean Water Act provides that any person who knowingly makes any false statement, representation, or certification in any record or other document submitted or required to be maintained under this permit, including monitoring reports or reports of compliance or noncompliance, shall, upon conviction, be punished by a fine of not more than \$10,000 per violation, or by imprisonment for not more than 6 months per violation, or by both.

The NREPA (Section 3115(2)) provides that a person who at the time of the violation knew or should have known that he or she discharged a substance contrary to this part, or contrary to a permit, COC, or order issued or rule promulgated under this part, or who intentionally makes a false statement, representation, or certification in an application for or form pertaining to a permit or COC or in a notice or report required by the terms and conditions of an issued permit or COC, or who intentionally renders inaccurate a monitoring device or record required to be maintained by the Department, is guilty of a felony and shall be fined not less than \$2,500.00 or more than \$25,000.00 for each violation. The court may impose an additional fine of not more than \$25,000.00 for each day during which the unlawful discharge occurred. If the conviction is for a violation committed after a first conviction of the person under this subsection, the court shall impose a fine of not less than \$25,000.00 per day and not more than \$50,000.00 per day of violation. Upon conviction, in addition to a fine, the court in its discretion may sentence the defendant to imprisonment for not more than 2 years or impose probation upon a person for a violation of this part. With the exception of the issuance of criminal complaints, issuance of warrants, and the holding of an arraignment, the circuit court for the county in which the violation occurred has exclusive jurisdiction. However, the person shall not be subject to the penalties of this subsection if the discharge of the effluent is in conformance with and obedient to a rule, order, permit, or COC of the Department. In addition to a fine, the attorney general may file a civil suit in a court of competent jurisdiction to recover the full value of the injuries done to the natural resources of the state and the costs of surveillance and enforcement by the state resulting from the violation.

**16. Electronic Reporting**

Upon notice by the Department that electronic reporting tools are available for specific reports or notifications, the permittee shall submit electronically all such reports or notifications as required by this permit, on forms provided by the Department.

**PART II****Section D. Management Responsibilities****1. Duty to Comply**

All discharges authorized herein shall be consistent with the terms and conditions of this permit. The discharge of any pollutant identified in this permit, more frequently than, or at a level in excess of, that authorized, shall constitute a violation of the permit.

It is the duty of the permittee to comply with all the terms and conditions of this permit. Any noncompliance with the Effluent Limitations, Special Conditions, or terms of this permit constitutes a violation of the NREPA and/or the Clean Water Act and constitutes grounds for enforcement action; for permit or Certificate of Coverage (COC) termination, revocation and reissuance, or modification; or denial of an application for permit or COC renewal.

It shall not be a defense for a permittee in an enforcement action that it would have been necessary to halt or reduce the permitted activity in order to maintain compliance with the conditions of this permit.

**2. Operator Certification**

The permittee shall have the waste treatment facilities under direct supervision of an operator certified at the appropriate level for the facility certification by the Department, as required by Sections 3110 and 4104 of the NREPA. Permittees authorized to discharge storm water shall have the storm water treatment and/or control measures under direct supervision of a storm water operator certified by the Department, as required by Section 3110 of the NREPA.

**3. Facilities Operation**

The permittee shall, at all times, properly operate and maintain all treatment or control facilities or systems installed or used by the permittee to achieve compliance with the terms and conditions of this permit. Proper operation and maintenance includes adequate laboratory controls and appropriate quality assurance procedures.

**4. Power Failures**

In order to maintain compliance with the effluent limitations of this permit and prevent unauthorized discharges, the permittee shall either:

- a. provide an alternative power source sufficient to operate facilities utilized by the permittee to maintain compliance with the effluent limitations and conditions of this permit; or
- b. upon the reduction, loss, or failure of one or more of the primary sources of power to facilities utilized by the permittee to maintain compliance with the effluent limitations and conditions of this permit, the permittee shall halt, reduce or otherwise control production and/or all discharge in order to maintain compliance with the effluent limitations and conditions of this permit.

**5. Adverse Impact**

The permittee shall take all reasonable steps to minimize or prevent any adverse impact to the surface waters or groundwaters of the state resulting from noncompliance with any effluent limitation specified in this permit including, but not limited to, such accelerated or additional monitoring as necessary to determine the nature and impact of the discharge in noncompliance.

**PART II****Section D. Management Responsibilities****6. Containment Facilities**

The permittee shall provide facilities for containment of any accidental losses of polluting materials in accordance with the requirements of the Part 5 Rules (R 324.2001 through R 324.2009 of the Michigan Administrative Code). For a POTW, these facilities shall be approved under Part 41 of the NREPA.

**7. Waste Treatment Residues**

Residuals (i.e. solids, sludges, biosolids, filter backwash, scrubber water, ash, grit, or other pollutants or wastes) removed from or resulting from treatment or control of wastewaters, including those that are generated during treatment or left over after treatment or control has ceased, shall be disposed of in an environmentally compatible manner and according to applicable laws and rules. These laws may include, but are not limited to, the NREPA, Part 31 for protection of water resources, Part 55 for air pollution control, Part 111 for hazardous waste management, Part 115 for solid waste management, Part 121 for liquid industrial wastes, Part 301 for protection of inland lakes and streams, and Part 303 for wetlands protection. Such disposal shall not result in any unlawful pollution of the air, surface waters or groundwaters of the state.

**8. Right of Entry**

The permittee shall allow the Department, any agent appointed by the Department, or the Regional Administrator, upon the presentation of credentials and, for animal feeding operation facilities, following appropriate biosecurity protocols:

- a. to enter upon the permittee's premises where an effluent source is located or any place in which records are required to be kept under the terms and conditions of this permit; and
- b. at reasonable times to have access to and copy any records required to be kept under the terms and conditions of this permit; to inspect process facilities, treatment works, monitoring methods and equipment regulated or required under this permit; and to sample any discharge of pollutants.

**9. Availability of Reports**

Except for data determined to be confidential under Section 308 of the Clean Water Act and Rule 2128 (R 323.2128 of the Michigan Administrative Code), all reports prepared in accordance with the terms of this permit, shall be available for public inspection at the offices of the Department and the Regional Administrator. As required by the Clean Water Act, effluent data shall not be considered confidential. Knowingly making any false statement on any such report may result in the imposition of criminal penalties as provided for in Section 309 of the Clean Water Act and Sections 3112, 3115, 4106 and 4110 of the NREPA.

**10. Duty to Provide Information**

The permittee shall furnish to the Department, within a reasonable time, any information which the Department may request to determine whether cause exists for modifying, revoking and reissuing, or terminating this permit or the facility's COC, or to determine compliance with this permit. The permittee shall also furnish to the Department, upon request, copies of records required to be kept by this permit.

Where the permittee becomes aware that it failed to submit any relevant facts in a permit application, or submitted incorrect information in a permit application or in any report to the Department, it shall promptly submit such facts or information.

**PART II****Section E. Activities Not Authorized by This Permit****1. Discharge to the Groundwaters**

This permit does not authorize any discharge to the groundwaters. Such discharge may be authorized by a groundwater discharge permit issued pursuant to the NREPA.

**2. POTW Construction**

This permit does not authorize or approve the construction or modification of any physical structures or facilities at a POTW. Approval for the construction or modification of any physical structures or facilities at a POTW shall be by permit issued under Part 41 of the NREPA.

**3. Civil and Criminal Liability**

Except as provided in permit conditions on "Bypass" (Part II.C.9. pursuant to 40 CFR 122.41(m)), nothing in this permit shall be construed to relieve the permittee from civil or criminal penalties for noncompliance, whether or not such noncompliance is due to factors beyond the permittee's control, such as accidents, equipment breakdowns, or labor disputes.

**4. Oil and Hazardous Substance Liability**

Nothing in this permit shall be construed to preclude the institution of any legal action or relieve the permittee from any responsibilities, liabilities, or penalties to which the permittee may be subject under Section 311 of the Clean Water Act except as are exempted by federal regulations.

**5. State Laws**

Nothing in this permit shall be construed to preclude the institution of any legal action or relieve the permittee from any responsibilities, liabilities, or penalties established pursuant to any applicable state law or regulation under authority preserved by Section 510 of the Clean Water Act.

**6. Property Rights**

The issuance of this permit does not convey any property rights in either real or personal property, or any exclusive privileges, nor does it authorize violation of any federal, state or local laws or regulations, nor does it obviate the necessity of obtaining such permits, including any other Department of Environment, Great Lakes, and Energy permits, or approvals from other units of government as may be required by law.

# Appendix 6

---

City of Grand Ledge WWTP Improvements

SRF Project Plan - Detailed Cost Summary & Useful Life Evaluation

Alternative 2 - Optimization of Existing Facilities: Expansion of Conventional Activated Sludge

Item	Unit	Quantity	Material Unit Cost	Material Subtotal	Install Unit Cost	Install Subtotal	2023 Construction Cost	Useful Life (Years)	Total Life Value	Weighted Useful Life	Future Salvage Value	Present Worth of Salvage Value
<b>Flow Retention</b>												
Excavation and Backfill	CYD	12,000	\$ -	\$ -	\$ 178	\$ 2,133,000	\$ 2,133,000	0	\$ -		\$ -	\$ -
Concrete	CYD	3,450	\$ 2,222	\$ 7,665,469	\$ -	\$ -	\$ 7,665,000	50	\$ 383,250,000		\$ 4,599,000	\$ 4,162,384
Access Hatch	EA	2	\$ 35,550	\$ 71,100	\$ 10,665	\$ 21,330	\$ 92,000	20	\$ 1,840,000		\$ -	\$ -
Flushing System	LS	1	\$ 888,750	\$ 888,750	\$ 266,625	\$ 266,625	\$ 1,155,000	50	\$ 57,750,000	41.3	\$ 693,000	\$ 627,209
Pumps	EA	2	\$ 160,864	\$ 321,728	\$ 48,259	\$ 96,518	\$ 418,000	20	\$ 8,360,000		\$ -	\$ -
Site Piping Force Main	LF	1,290	\$ 889	\$ 1,146,488	\$ 267	\$ 343,946	\$ 1,490,000	50	\$ 74,500,000		\$ 894,000	\$ 809,126
Site Piping Gravity Sewer	LF	1,310	\$ 889	\$ 1,164,263	\$ 267	\$ 349,279	\$ 1,514,000	50	\$ 75,700,000		\$ 908,400	\$ 822,159
Electrical, Instrumentation, and Controls	LS	1	\$ 97,763	\$ 97,763	\$ 30,218	\$ 30,218	\$ 128,000	15	\$ 1,920,000		\$ -	\$ -
							<b>Subtotal Flow Retention</b>		<b>\$ 603,320,000</b>		<b>\$ 7,094,400</b>	<b>\$ 6,420,878</b>
<b>Preliminary Treatment</b>												
Demolition of Existing Grit and Site Piping	LS	1	\$ -	\$ -	\$ 235,519	\$ 235,519	\$ 236,000	0	\$ -		\$ -	\$ -
Screen	LS	1	\$ 346,613	\$ 346,613	\$ 103,984	\$ 103,984	\$ 451,000	20	\$ 9,020,000		\$ -	\$ -
Vortex Grit Removal	LS	1	\$ 341,280	\$ 341,280	\$ 102,384	\$ 102,384	\$ 444,000	50	\$ 22,200,000		\$ 266,400	\$ 241,109
Conveyor	LS	1	\$ 71,100	\$ 71,100	\$ 21,330	\$ 21,330	\$ 92,000	20	\$ 1,840,000	29.6	\$ -	\$ -
Site Piping	LF	130	\$ 711	\$ 92,430	\$ -	\$ -	\$ 92,000	50	\$ 4,600,000		\$ 55,200	\$ 49,959
Building Addition	SQFT	1,200	\$ 284	\$ 341,280	\$ -	\$ -	\$ 341,000	50	\$ 17,050,000		\$ 204,600	\$ 185,176
Site Restoration	LS	1	\$ 26,663	\$ 26,663	\$ 7,999	\$ 7,999	\$ 35,000	0	\$ -		\$ -	\$ -
Electrical, Instrumentation, and Controls	LS	1	\$ 239,963	\$ 239,963	\$ 72,878	\$ 72,878	\$ 313,000	15	\$ 4,695,000		\$ -	\$ -
							<b>Subtotal Preliminary Treatment</b>		<b>\$ 59,405,000</b>		<b>\$ 526,200</b>	<b>\$ 476,244</b>
<b>Primary Clarification</b>												
Digester Demolition	LS	1	\$ -	\$ -	\$ 177,750	\$ 177,750	\$ 178,000	0	\$ -		\$ -	\$ -
Primary Clarifier Mechanisms Demolition	LS	1	\$ -	\$ -	\$ 88,875	\$ 88,875	\$ 89,000	0	\$ -		\$ -	\$ -
Site Restoration	LS	1	\$ 17,775	\$ 17,775	\$ 3,555	\$ 3,555	\$ 21,000	0	\$ -		\$ -	\$ -
Excavation and Backfill	CYD	1,900	\$ -	\$ -	\$ 178	\$ 337,725	\$ 338,000	0	\$ -		\$ -	\$ -
Concrete	CYD	940	\$ 2,222	\$ 2,088,563	\$ -	\$ -	\$ 2,089,000	50	\$ 104,450,000		\$ 1,253,400	\$ 1,134,406
Site Piping	LF	570	\$ 711	\$ 405,270	\$ -	\$ -	\$ 405,000	50	\$ 20,250,000	31.5	\$ 243,000	\$ 219,930
Clarifier Mechanism and Drive	EA	3	\$ 284,400	\$ 853,200	\$ 113,760	\$ 341,280	\$ 1,194,000	20	\$ 23,880,000		\$ -	\$ -
Sludge Pump	EA	3	\$ 28,156	\$ 84,467	\$ 8,461	\$ 25,383	\$ 110,000	20	\$ 2,200,000		\$ -	\$ -
Sludge Piping	LF	340	\$ 356	\$ 120,870	\$ -	\$ -	\$ 121,000	50	\$ 6,050,000		\$ 72,600	\$ 65,708
Handrail and Grating	LS	1	\$ 133,313	\$ 133,313	\$ 39,994	\$ 39,994	\$ 173,000	50	\$ 8,650,000		\$ 103,800	\$ 93,946
Electrical, Instrumentation, and Controls	LS	1	\$ 742,995	\$ 742,995	\$ 273,735	\$ 273,735	\$ 1,017,000	15	\$ 15,255,000		\$ -	\$ -
							<b>Subtotal Primary Clarification</b>		<b>\$ 180,735,000</b>		<b>\$ 1,672,800</b>	<b>\$ 1,513,989</b>
<b>Biological Treatment</b>												
Modification to Existing Primary Clarifiers	LS	1	\$ -	\$ -	\$ 355,500	\$ 355,500	\$ 356,000	50	\$ 17,800,000		\$ 213,600	\$ 193,321
Site Restoration	LS	1	\$ 17,775	\$ 17,775	\$ 5,333	\$ 5,333	\$ 23,000	0	\$ -		\$ -	\$ -
Excavation and Backfill	CYD	1,345	\$ -	\$ -	\$ 178	\$ 239,074	\$ 239,000	0	\$ -		\$ -	\$ -
Concrete	CYD	840	\$ 2,222	\$ 1,866,375	\$ -	\$ -	\$ 1,866,000	50	\$ 93,300,000		\$ 1,119,600	\$ 1,013,308
Site Piping	LF	650	\$ 889	\$ 577,688	\$ -	\$ -	\$ 578,000	50	\$ 28,900,000		\$ 346,800	\$ 313,876
Diffusers and Aeration Equipment	EA	5	\$ 266,625	\$ 1,333,125	\$ 79,988	\$ 399,938	\$ 1,733,000	20	\$ 34,660,000	15.0	\$ -	\$ -
Blower	EA	5	\$ 266,625	\$ 1,333,125	\$ 79,988	\$ 399,938	\$ 1,733,000	20	\$ 34,660,000		\$ -	\$ -
Blower VFD	EA	5	\$ 62,213	\$ 311,063	\$ 18,664	\$ 93,319	\$ 404,000	15	\$ 6,060,000		\$ -	\$ -
DO and Level Sensor	EA	4	\$ 62,213	\$ 248,850	\$ 18,664	\$ 74,655	\$ 324,000	15	\$ 4,860,000		\$ -	\$ -
Grating For Aeration Basins	SQFT	1,200	\$ 142	\$ 170,640	\$ 47	\$ 56,311	\$ 227,000	50	\$ 11,350,000		\$ 136,200	\$ 123,270
Sampler	EA	1	\$ 35,550	\$ 35,550	\$ 11,732	\$ 11,732	\$ 47,000	20	\$ 940,000		\$ -	\$ -
Electrical, Instrumentation, and Controls	LS	1	\$ 954,518	\$ 954,518	\$ 295,776	\$ 295,776	\$ 1,250,000	15	\$ 18,750,000		\$ -	\$ -
							<b>Subtotal Biological Treatment</b>		<b>\$ 251,280,000</b>		<b>\$ 1,816,200</b>	<b>\$ 1,643,775</b>

City of Grand Ledge WWTP Improvements

SRF Project Plan - Detailed Cost Summary & Useful Life Evaluation

Alternative 2 - Optimization of Existing Facilities: Expansion of Conventional Activated Sludge

Item	Unit	Quantity	Material Unit Cost	Material Subtotal	Install Unit Cost	Install Subtotal	2023 Construction Cost	Useful Life (Years)	Total Life Value	Weighted Useful Life	Future Salvage Value	Present Worth of Salvage Value
<b>Final Clarification</b>												
Demolition of Existing Finals	LS	1	\$ -	\$ -	\$ 471,038	\$ 471,038	\$ 471,000	0	\$ -		\$ -	\$ -
Site Restoration	LS	1	\$ 17,775	\$ 17,775	\$ 5,333	\$ 5,333	\$ 23,000	0	\$ -		\$ -	\$ -
Excavation and Backfill	CYD	3,943	\$ -	\$ -	\$ 178	\$ 700,928	\$ 701,000	0	\$ -		\$ -	\$ -
Concrete	CYD	1,380	\$ 2,222	\$ 3,066,188	\$ -	\$ -	\$ 3,066,000	50	\$ 153,300,000		\$ 1,839,600	\$ 1,664,954
Site Piping	LS	85	\$ 711	\$ 60,435	\$ -	\$ -	\$ 60,000	50	\$ 3,000,000		\$ 36,000	\$ 32,582
Final Clarifier Internal Mechanism	EA	3	\$ 533,250	\$ 1,599,750	\$ 53,325	\$ 159,975	\$ 1,760,000	20	\$ 35,200,000		\$ -	\$ -
Sludge Pump	EA	4	\$ 28,156	\$ 112,622	\$ 8,447	\$ 33,787	\$ 146,000	20	\$ 2,920,000	50.0	\$ -	\$ -
Sludge Meter	EA	4	\$ 8,888	\$ 35,550	\$ 2,666	\$ 10,665	\$ 46,000	20	\$ 920,000		\$ -	\$ -
RAS Pipe	LF	490	\$ 356	\$ 174,195	\$ -	\$ -	\$ 174,000	50	\$ 8,700,000		\$ 104,400	\$ 94,489
WAS Pipe	LF	490	\$ 356	\$ 174,195	\$ -	\$ -	\$ 174,000	50	\$ 8,700,000		\$ 104,400	\$ 94,489
Tank Coating	EA	3	\$ 17,775	\$ 53,325	\$ 5,333	\$ 15,998	\$ 69,000	15	\$ 1,035,000		\$ -	\$ -
Handrail and Grating	SQFT	987	\$ 142	\$ 140,378	\$ 43	\$ 42,113	\$ 182,000	50	\$ 9,100,000		\$ 109,200	\$ 98,833
Launder Cover	EA	3	\$ 65,234	\$ 195,703	\$ 19,570	\$ 58,711	\$ 254,000	20	\$ 5,080,000		\$ -	\$ -
Electrical, Instrumentation, and Controls	LS	1	\$ 805,208	\$ 805,208	\$ 241,740	\$ 241,740	\$ 1,047,000	15	\$ 15,705,000		\$ -	\$ -
<b>Subtotal Final Clarification</b>							<b>\$ 8,173,000</b>		<b>\$ 243,660,000</b>		<b>\$ 2,193,600</b>	<b>\$ 1,985,346</b>
<b>Disinfection</b>												
Excavation and Backfill	CYD	100	\$ -	\$ -	\$ 178	\$ 17,775	\$ 18,000	0	\$ -		\$ -	\$ -
Concrete	CYD	40	\$ 2,222	\$ 88,875	\$ 667	\$ 26,663	\$ 116,000	50	\$ 5,800,000		\$ 69,600	\$ 62,992
UV Equipment	LS	1	\$ 1,066,500	\$ 1,066,500	\$ 319,950	\$ 319,950	\$ 1,386,000	20	\$ 27,720,000	23.8	\$ -	\$ -
Site Piping	LF	210	\$ 800	\$ 167,974	\$ 240	\$ 50,392	\$ 218,000	50	\$ 10,900,000		\$ 130,800	\$ 118,382
Electrical, Instrumentation, and Controls	LS	1	\$ 264,848	\$ 264,848	\$ 79,988	\$ 79,988	\$ 345,000	15	\$ 5,175,000		\$ -	\$ -
<b>Subtotal Disinfection</b>							<b>\$ 2,083,000</b>		<b>\$ 49,595,000</b>		<b>\$ 200,400</b>	<b>\$ 181,375</b>
<b>Solids Handling</b>												
Process Piping Modifications	LS	1	\$ 444,375	\$ 444,375	\$ -	\$ -	\$ 444,000	50	\$ 22,200,000		\$ 266,400	\$ 241,109
Dewatering Equipment	EA	2	\$ 133,313	\$ 266,625	\$ 39,994	\$ 79,988	\$ 347,000	20	\$ 6,940,000		\$ -	\$ -
Polymer Feed Equipment	LS	1	\$ 35,550	\$ 35,550	\$ 10,665	\$ 10,665	\$ 46,000	20	\$ 920,000	34.3	\$ -	\$ -
Lime Storage	LS	1	\$ 266,625	\$ 266,625	\$ 79,988	\$ 79,988	\$ 347,000	50	\$ 17,350,000		\$ 208,200	\$ 188,434
Lime Feed Equipment	LS	1	\$ 177,750	\$ 177,750	\$ 53,325	\$ 53,325	\$ 231,000	20	\$ 4,620,000		\$ -	\$ -
Electrical, Instrumentation, and Controls	LS	1	\$ 142,200	\$ 142,200	\$ 42,660	\$ 42,660	\$ 185,000	15	\$ 2,775,000		\$ -	\$ -
<b>Subtotal Solids Handling</b>							<b>\$ 1,600,000</b>		<b>\$ 54,805,000</b>		<b>\$ 474,600</b>	<b>\$ 429,543</b>
<b>TOTAL WWTP PROJECT ESTIMATED COST</b>							<b>\$ 42,970,000</b>	<b>WEGHTED USEFUL LIFE</b>	<b>\$ 1,442,800,000</b>	<b>33.6</b>	<b>\$ 13,978,200</b>	<b>\$ 12,651,150</b>

City of Grand Ledge WWTP Improvements

SRF Project Plan - Detailed Cost Summary & Useful Life Evaluation

Alternative 3 - Optimization of Existing Facilities: Conversion to Extended Aeration

Item	Unit	Quantity	Material Unit Cost	Material Subtotal	Install Unit Cost	Install Subtotal	2023 Construction Cost	Useful Life (Years)	Total Life Value	Weighted Useful Life	Future Salvage Value	Present Worth of Salvage Value
<b>Flow Retention</b>												
Excavation and Backfill	CYD	12,000	\$ -	\$ -	\$ 184	\$ 2,211,720	\$ 2,212,000	0	\$ -		\$ -	\$ -
Concrete	CYD	3,450	\$ 2,304	\$ 7,948,369	\$ -	\$ -	\$ 7,948,000	50	\$ 397,400,000		\$ 4,768,800	\$ 4,316,064
Access Hatch	EA	2	\$ 36,862	\$ 73,724	\$ 11,059	\$ 22,117	\$ 96,000	20	\$ 1,920,000		\$ -	\$ -
Flushing System	LS	1	\$ 921,550	\$ 921,550	\$ 276,465	\$ 276,465	\$ 1,198,000	50	\$ 59,900,000	41.3	\$ 718,800	\$ 650,559
Pumps	EA	2	\$ 166,801	\$ 333,601	\$ 50,040	\$ 100,080	\$ 434,000	20	\$ 8,680,000		\$ -	\$ -
Site Piping Force Main	LF	1,290	\$ 922	\$ 1,188,800	\$ 276	\$ 356,640	\$ 1,545,000	50	\$ 77,250,000		\$ 927,000	\$ 838,993
Site Piping Gravity Sewer	LF	1,310	\$ 922	\$ 1,207,231	\$ 276	\$ 362,169	\$ 1,569,000	50	\$ 78,450,000		\$ 941,400	\$ 852,026
Electrical, Instrumentation, and Controls	LS	1	\$ 101,371	\$ 101,371	\$ 31,333	\$ 31,333	\$ 133,000	15	\$ 1,995,000		\$ -	\$ -
							<b>Subtotal Flow Retention</b>		<b>\$ 625,595,000</b>		<b>\$ 7,356,000</b>	<b>\$ 6,657,643</b>
<b>Preliminary Treatment</b>												
Demolition of Existing Grit and Site Piping	LS	1	\$ -	\$ -	\$ 244,211	\$ 244,211	\$ 244,000	0	\$ -		\$ -	\$ -
Screen	LS	1	\$ 359,405	\$ 359,405	\$ 107,821	\$ 107,821	\$ 467,000	20	\$ 9,340,000		\$ -	\$ -
Vortex Grit Removal	LS	1	\$ 353,875	\$ 353,875	\$ 106,163	\$ 106,163	\$ 460,000	50	\$ 23,000,000		\$ 276,000	\$ 249,797
Conveyor	LS	1	\$ 73,724	\$ 73,724	\$ 22,117	\$ 22,117	\$ 96,000	20	\$ 1,920,000		\$ -	\$ -
Site Piping	LF	130	\$ 737	\$ 95,811	\$ -	\$ -	\$ 96,000	50	\$ 4,800,000	29.7	\$ 57,600	\$ 52,132
Building Addition	SQFT	1,200	\$ 295	\$ 353,875	\$ -	\$ -	\$ 354,000	50	\$ 17,700,000		\$ 212,400	\$ 192,235
Site Restoration	LS	1	\$ 27,647	\$ 27,647	\$ 8,294	\$ 8,294	\$ 36,000	0	\$ -		\$ -	\$ -
Electrical, Instrumentation, and Controls	LS	1	\$ 248,819	\$ 248,819	\$ 75,567	\$ 75,567	\$ 324,000	15	\$ 4,860,000		\$ -	\$ -
							<b>Subtotal Preliminary Treatment</b>		<b>\$ 61,620,000</b>		<b>\$ 546,000</b>	<b>\$ 494,164</b>
<b>Primary Clarification</b>												
Digester Demolition	LS	1	\$ -	\$ -	\$ 184,310	\$ 184,310	\$ 184,000	0	\$ -		\$ -	\$ -
Primary Clarifier Mechanisms Demolition	LS	1	\$ -	\$ -	\$ 92,155	\$ 92,155	\$ 92,000	0	\$ -	0.0	\$ -	\$ -
Site Restoration	LS	1	\$ 18,431	\$ 18,431	\$ 3,686	\$ 3,686	\$ 22,000	0	\$ -		\$ -	\$ -
							<b>Subtotal Primary Clarification</b>		<b>\$ 298,000</b>		<b>\$ -</b>	<b>\$ -</b>
<b>Biological Treatment</b>												
Modifications to Existing Aeration and												
Primary Tanks	LS	1	\$ 184,310	\$ 184,310	\$ 184,310	\$ 184,310	\$ 369,000	50	\$ 18,450,000		\$ 221,400	\$ 200,381
Site Work	LS	1	\$ 27,647	\$ 27,647	\$ 8,294	\$ 8,294	\$ 36,000	0	\$ -		\$ -	\$ -
Excavation and Backfill	CYD	7,783	\$ -	\$ -	\$ 276	\$ 2,151,819	\$ 2,152,000	0	\$ -		\$ -	\$ -
Concrete	CYD	3,177	\$ 2,304	\$ 7,318,643	\$ -	\$ -	\$ 7,319,000	50	\$ 365,950,000		\$ 4,391,400	\$ 3,974,493
Site Piping	LF	1,480	\$ 737	\$ 1,091,115	\$ -	\$ -	\$ 1,091,000	50	\$ 54,550,000	#REF!	\$ 654,600	\$ 592,454
Aeration Equipment	EA	3	\$ 921,550	\$ 2,764,650	\$ 230,388	\$ 691,163	\$ 3,456,000	20	\$ 69,120,000		\$ -	\$ -
WAS Pipe	LF	600	\$ 369	\$ 221,172	\$ -	\$ -	\$ 221,000	50	\$ 11,050,000		\$ 132,600	\$ 120,011
Sludge Pump	EA	5	\$ 29,195	\$ 145,974	\$ 8,758	\$ 43,792	\$ 190,000	20	\$ 3,800,000		\$ -	\$ -
Sludge Meter	EA	4	\$ 9,216	\$ 36,862	\$ 2,765	\$ 11,059	\$ 48,000	15	\$ 720,000		\$ -	\$ -
Sampler	EA	4	\$ 36,862	\$ 147,448	\$ 11,059	\$ 44,234	\$ 192,000	20	\$ 3,840,000		\$ -	\$ -
Electrical, Instrumentation, and Controls	LS	1	\$ 1,795,179	\$ 1,795,179	\$ 541,871	\$ 541,871	\$ 2,337,000	15	\$ 35,055,000		\$ -	\$ -
							<b>Subtotal Biological Treatment</b>		<b>\$ 562,535,000</b>		<b>\$ 5,400,000</b>	<b>\$ 4,887,340</b>

City of Grand Ledge WWTP Improvements

SRF Project Plan - Detailed Cost Summary & Useful Life Evaluation

Alternative 3 - Optimization of Existing Facilities: Conversion to Extended Aeration

Item	Unit	Quantity	Material Unit Cost	Material Subtotal	Install Unit Cost	Install Subtotal	2023 Construction Cost	Useful Life (Years)	Total Life Value	Weighted Useful Life	Future Salvage Value	Present Worth of Salvage Value
<b>Final Clarification</b>												
Site Restoration	LS	1	\$ 18,431	\$ 18,431	\$ 5,529	\$ 5,529	\$ 24,000	0	\$ -		\$ -	\$ -
Digester Demolition	LS	1	\$ -	\$ -	\$ 184,310	\$ 184,310	\$ 184,000	0	\$ -		\$ -	\$ -
Excavation and Backfill	CYD	2,635	\$ -	\$ -	\$ 184	\$ 485,657	\$ 486,000	0	\$ -		\$ -	\$ -
Concrete	CYD	920	\$ 2,304	\$ 2,119,565	\$ -	\$ -	\$ 2,120,000	50	\$ 106,000,000		\$ 1,272,000	\$ 1,151,240
Site Piping	LS	685	\$ 737	\$ 505,009	\$ -	\$ -	\$ 505,000	50	\$ 25,250,000		\$ 303,000	\$ 274,234
Final Clarifier Internal Mechanism	EA	2	\$ 552,930	\$ 1,105,860	\$ 55,293	\$ 110,586	\$ 1,216,000	20	\$ 24,320,000		\$ -	\$ -
Sludge Pump	EA	2	\$ 29,195	\$ 58,389	\$ 8,758	\$ 17,517	\$ 76,000	20	\$ 1,520,000	20.0	\$ -	\$ -
RAS Pipe	LF	220	\$ 369	\$ 81,096	\$ -	\$ -	\$ 81,000	50	\$ 4,050,000		\$ 48,600	\$ 43,986
WAS Pipe	LF	220	\$ 369	\$ 81,096	\$ -	\$ -	\$ 81,000	50	\$ 4,050,000		\$ 48,600	\$ 43,986
Tank Coating	LS	2	\$ 18,431	\$ 36,862	\$ 5,529	\$ 11,059	\$ 48,000	15	\$ 720,000		\$ -	\$ -
Handrail and Grating	SQFT	658	\$ 147	\$ 97,039	\$ 44	\$ 29,112	\$ 126,000	50	\$ 6,300,000		\$ 75,600	\$ 68,423
Lauder Cover	EA	2	\$ 67,642	\$ 135,284	\$ 20,293	\$ 40,585	\$ 176,000	20	\$ 3,520,000		\$ -	\$ -
Electrical, Instrumentation, and Controls	LS	1	\$ 903,119	\$ 903,119	\$ 272,779	\$ 272,779	\$ 1,176,000	15	\$ 17,640,000		\$ -	\$ -
<b>Subtotal Final Clarification</b>							<b>\$ 6,299,000</b>		<b>\$ 193,370,000</b>		<b>\$ 1,747,800</b>	<b>\$ 1,581,869</b>
<b>Disinfection</b>												
Excavation and Backfill	CYD	100	\$ -	\$ -	\$ 184	\$ 18,431	\$ 18,000	0	\$ -		\$ -	\$ -
Concrete	CYD	40	\$ 2,304	\$ 92,155	\$ 691	\$ 27,647	\$ 120,000	50	\$ 6,000,000		\$ 72,000	\$ 65,165
UV Equipment	LS	1	\$ 1,105,860	\$ 1,105,860	\$ 331,758	\$ 331,758	\$ 1,438,000	20	\$ 28,760,000	23.8	\$ -	\$ -
Site Piping	LF	210	\$ 829	\$ 174,173	\$ 249	\$ 52,252	\$ 226,000	50	\$ 11,300,000		\$ 135,600	\$ 122,727
Electrical, Instrumentation, and Controls	LS	1	\$ 274,622	\$ 274,622	\$ 82,940	\$ 82,940	\$ 358,000	15	\$ 5,370,000		\$ -	\$ -
<b>Subtotal Disinfection</b>							<b>\$ 2,160,000</b>		<b>\$ 51,430,000</b>		<b>\$ 207,600</b>	<b>\$ 187,891</b>
<b>Solids Handling</b>												
Process Piping Modifications	LS	1	\$ 460,775	\$ 460,775	\$ -	\$ -	\$ 461,000	50	\$ 23,050,000		\$ 276,600	\$ 250,340
Dewatering Equipment	EA	2	\$ 138,233	\$ 276,465	\$ 41,470	\$ 82,940	\$ 359,000	20	\$ 7,180,000		\$ -	\$ -
Polymer Feed Equipment	LS	1	\$ 36,862	\$ 36,862	\$ 11,059	\$ 11,059	\$ 48,000	20	\$ 960,000	34.2	\$ -	\$ -
Lime Storage	LS	1	\$ 276,465	\$ 276,465	\$ 82,940	\$ 82,940	\$ 359,000	50	\$ 17,950,000		\$ 215,400	\$ 194,951
Lime Feed Equipment	LS	1	\$ 184,310	\$ 184,310	\$ 55,293	\$ 55,293	\$ 240,000	20	\$ 4,800,000		\$ -	\$ -
Electrical, Instrumentation, and Controls	LS	1	\$ 147,448	\$ 147,448	\$ 44,234	\$ 44,234	\$ 192,000	15	\$ 2,880,000		\$ -	\$ -
<b>Subtotal Solids Handling</b>							<b>\$ 1,659,000</b>		<b>\$ 56,820,000</b>		<b>\$ 492,000</b>	<b>\$ 445,291</b>
<b>TOTAL WWTP PROJECT ESTIMATED COST</b>							<b>\$ 45,039,000</b>		<b>\$ 1,551,370,000</b>	<b>34.4</b>	<b>\$ 15,749,400</b>	<b>\$ 14,254,198</b>

City of Grand Ledge WWTP Improvements

SRF Project Plan - Detailed Cost Summary & Useful Life Evaluation

Alternative 4 - Optimization of Existing Facilities: Conversion to Membrane Bioreactors

Item	Unit	Quantity	Material Unit Cost	Material Subtotal	Install Unit Cost	Install Subtotal	2023 Construction Cost	Useful Life (Years)	Total Life Value	Weighted Useful Life	Future Salvage Value	Present Worth of Salvage Value
<b>Flow Retention</b>												
Excavation and Backfill	CYD	12,000	\$ -	\$ -	\$ 187	\$ 2,240,640	\$ 2,241,000	0	\$ -		\$ -	\$ -
Concrete	CYD	3,450	\$ 2,334	\$ 8,052,300	\$ -	\$ -	\$ 8,052,000	50	\$ 402,600,000		\$ 4,831,200	\$ 4,372,540
Access Hatch	EA	2	\$ 37,344	\$ 74,688	\$ 11,203	\$ 22,406	\$ 97,000	20	\$ 1,940,000		\$ -	\$ -
Flushing System	LS	1	\$ 933,600	\$ 933,600	\$ 280,080	\$ 280,080	\$ 1,214,000	50	\$ 60,700,000	41.3	\$ 728,400	\$ 659,248
Pumps	EA	2	\$ 168,982	\$ 337,963	\$ 50,694	\$ 101,389	\$ 439,000	20	\$ 8,780,000		\$ -	\$ -
Site Piping Force Main	LF	1,290	\$ 934	\$ 1,204,344	\$ 280	\$ 361,303	\$ 1,566,000	50	\$ 78,300,000		\$ 939,600	\$ 850,397
Site Piping Gravity Sewer	LF	1,310	\$ 934	\$ 1,223,016	\$ 280	\$ 366,905	\$ 1,590,000	50	\$ 79,500,000		\$ 954,000	\$ 863,430
Electrical, Instrumentation, and Controls	LS	1	\$ 102,696	\$ 102,696	\$ 31,742	\$ 31,742	\$ 134,000	15	\$ 2,010,000		\$ -	\$ -
							<b>Subtotal Flow Retention</b>		<b>\$ 633,830,000</b>		<b>\$ 7,453,200</b>	<b>\$ 6,745,615</b>
<b>Preliminary Treatment</b>												
Demolition of Existing Grit and Site Piping	LS	1	\$ -	\$ -	\$ 247,404	\$ 247,404	\$ 247,000	0	\$ -		\$ -	\$ -
Screen	LS	1	\$ 364,104	\$ 364,104	\$ 109,231	\$ 109,231	\$ 473,000	20	\$ 9,460,000		\$ -	\$ -
Vortex Grit Removal	LS	1	\$ 358,502	\$ 358,502	\$ 107,551	\$ 107,551	\$ 466,000	50	\$ 23,300,000		\$ 279,600	\$ 253,056
Conveyor	LS	1	\$ 74,688	\$ 74,688	\$ 22,406	\$ 22,406	\$ 97,000	20	\$ 1,940,000		\$ -	\$ -
Site Piping	LF	130	\$ 747	\$ 97,094	\$ -	\$ -	\$ 97,000	50	\$ 4,850,000	30.5	\$ 58,200	\$ 52,675
Building Addition	SQFT	1,200	\$ 299	\$ 358,502	\$ -	\$ -	\$ 359,000	50	\$ 17,950,000		\$ 215,400	\$ 194,951
Site Restoration	LS	1	\$ 28,008	\$ 28,008	\$ 8,402	\$ 8,402	\$ 36,000	50	\$ 1,800,000		\$ 21,600	\$ 19,549
Electrical, Instrumentation, and Controls	LS	1	\$ 252,072	\$ 252,072	\$ 76,555	\$ 76,555	\$ 329,000	15	\$ 4,935,000		\$ -	\$ -
							<b>Subtotal Preliminary Treatment</b>		<b>\$ 64,235,000</b>		<b>\$ 574,800</b>	<b>\$ 520,230</b>
<b>Primary Treatment</b>												
Digester Demolition	LS	1	\$ -	\$ -	\$ 186,720	\$ 186,720	\$ 187,000	0	\$ -		\$ -	\$ -
Site Restoration	LS	1	\$ 18,672	\$ 18,672	\$ 3,734	\$ 3,734	\$ 22,000	0	\$ -	13.4	\$ -	\$ -
Microscreen	EA	4	\$ 345,432	\$ 1,381,728	\$ 103,630	\$ 414,518	\$ 1,796,000	15	\$ 26,940,000		\$ -	\$ -
							<b>Subtotal Primary Treatment</b>		<b>\$ 2,005,000</b>		<b>\$ 26,940,000</b>	<b>\$ -</b>
<b>Biological Treatment</b>												
Demolition of Primary and Final Clarifier Equipment	LS	1	\$ -	\$ -	\$ 373,440	\$ 373,440	\$ 373,000	0	\$ -		\$ -	\$ -
Modification of North Primary to Aeration	LS	1	\$ 280,080	\$ 280,080	\$ 84,024	\$ 84,024	\$ 364,000	50	\$ 18,200,000		\$ 218,400	\$ 197,666
Influent Channel from Aeration to MBRs	LS	1	\$ 186,720	\$ 186,720	\$ 186,720	\$ 186,720	\$ 373,000	50	\$ 18,650,000		\$ 223,800	\$ 202,553
Aeration Equipment	LS	1	\$ 813,166	\$ 813,166	\$ -	\$ -	\$ 813,000	20	\$ 16,260,000	22.1	\$ -	\$ -
Site Piping	LF	500	\$ 747	\$ 373,440	\$ -	\$ -	\$ 373,000	50	\$ 18,650,000		\$ 223,800	\$ 202,553
Membranes and Associated Equipment	LS	1	\$ 4,201,200	\$ 4,201,200	\$ 1,314,509	\$ 1,314,509	\$ 5,516,000	20	\$ 110,320,000		\$ -	\$ -
Level Sensor	EA	3	\$ 37,344	\$ 112,032	\$ 11,203	\$ 33,610	\$ 146,000	15	\$ 2,190,000		\$ -	\$ -
Electrical, Instrumentation, and Controls	LS	1	\$ 883,186	\$ 883,186	\$ 293,150	\$ 293,150	\$ 1,176,000	15	\$ 17,640,000		\$ -	\$ -
							<b>Subtotal Biological Treatment</b>		<b>\$ 201,910,000</b>		<b>\$ 666,000</b>	<b>\$ 602,772</b>

City of Grand Ledge WWTP Improvements

SRF Project Plan - Detailed Cost Summary & Useful Life Evaluation

Alternative 4 - Optimization of Existing Facilities: Conversion to Membrane Bioreactors

Item	Unit	Quantity	Material Unit Cost	Material Subtotal	Install Unit Cost	Install Subtotal	2023 Construction Cost	Useful Life (Years)	Total Life Value	Weighted Useful Life	Future Salvage Value	Present Worth of Salvage Value
<b>Final Clarification</b>												
Demolish Existing Final Clarifier Mechanisms	EA	2	\$ -	\$ -	\$ 140,040	\$ 280,080	\$ 280,000	0	\$ -	0.0	\$ -	\$ -
<b>Subtotal Final Clarification</b>							<b>\$ 280,000</b>		<b>\$ -</b>		<b>\$ -</b>	<b>\$ -</b>
<b>Disinfection</b>												
Concrete	CYD	20	\$ 2,334	\$ 46,680	\$ 700	\$ 14,004	\$ 61,000	50	\$ 3,050,000		\$ 36,600	\$ 33,125
UV Equipment	LS	1	\$ 840,240	\$ 840,240	\$ 252,072	\$ 252,072	\$ 1,092,000	20	\$ 21,840,000	20.0	\$ -	\$ -
Electrical, Instrumentation, and Controls	LS	1	\$ 278,213	\$ 278,213	\$ 84,024	\$ 84,024	\$ 362,000	15	\$ 5,430,000		\$ -	\$ -
<b>Subtotal Disinfection</b>							<b>\$ 1,515,000</b>		<b>\$ 30,320,000</b>		<b>\$ 36,600</b>	<b>\$ 33,125</b>
<b>Solids Handling</b>												
Process Piping Modifications	LS	1	\$ 466,800	\$ 466,800	\$ -	\$ -	\$ 467,000	50	\$ 23,350,000		\$ 280,200	\$ 253,599
Dewatering Equipment	EA	2	\$ 140,040	\$ 280,080	\$ 42,012	\$ 84,024	\$ 364,000	20	\$ 7,280,000		\$ -	\$ -
Polymer Feed Equipment	LS	1	\$ 37,344	\$ 37,344	\$ 11,203	\$ 11,203	\$ 49,000	20	\$ 980,000	34.3	\$ -	\$ -
Lime Storage	LS	1	\$ 280,080	\$ 280,080	\$ 84,024	\$ 84,024	\$ 364,000	50	\$ 18,200,000		\$ 218,400	\$ 197,666
Lime Feed Equipment	LS	1	\$ 186,720	\$ 186,720	\$ 56,016	\$ 56,016	\$ 243,000	20	\$ 4,860,000		\$ -	\$ -
Electrical, Instrumentation, and Controls	LS	1	\$ 149,376	\$ 149,376	\$ 44,813	\$ 44,813	\$ 194,000	15	\$ 2,910,000		\$ -	\$ -
<b>Subtotal Solids Handling</b>							<b>\$ 1,681,000</b>		<b>\$ 57,580,000</b>		<b>\$ 498,600</b>	<b>\$ 451,264</b>
<b>TOTAL WWTP PROJECT ESTIMATED COST</b>							<b>\$ 32,052,000</b>		<b>WEGHTED USEFUL LIFE \$ 1,014,815,000</b>	<b>31.7</b>	<b>\$ 9,229,200</b>	<b>\$ 8,353,007</b>

City of Grand Ledge WWTP Improvements

SRF Project Plan - Detailed Cost Summary & Useful Life Evaluation

Sanitary Sewer System Improvements

Item	Unit	Quantity	Material Unit Cost	Material Subtotal	Install Unit Cost	Install Subtotal	2023 Construction Cost	Useful Life (Years)	Total Life Value	Weighted Useful Life	Future Salvage Value	Present Worth of Salvage Value
WRPS Pump Replacement	EA	3	\$ 132,750	\$ 398,250	\$ 44,250	\$ 132,750	\$ 531,000	30	\$ 15,930,000		\$ 177,000	\$ 160,196
WRPS Forcemain	LF	7,000	\$ 124	\$ 867,300	\$ 35	\$ 247,800	\$ 1,115,000	50	\$ 55,750,000		\$ 669,000	\$ 605,487
WRPS Forcemain Jack and Bore	EA	1	\$ 88,500	\$ 88,500	\$ 88,500	\$ 88,500	\$ 177,000	50	\$ 8,850,000		\$ 106,200	\$ 96,118
WRPS Forcemain Restoration	LF	5,300	\$ 142	\$ 750,480	\$ 35	\$ 187,620	\$ 938,000	20	\$ 18,760,000	36.5	\$ -	\$ -
Green Street Demolition	LS	1	\$ -	\$ -	\$ 16,409	\$ 16,409	\$ 16,000	0	\$ -		\$ -	\$ -
Green Street Sanitary Sewer	LF	868	\$ 67	\$ 58,330	\$ 45	\$ 38,886	\$ 97,000	50	\$ 4,850,000		\$ 58,200	\$ 52,675
Green Street Sanitary Sewer Services	LF	475	\$ 59	\$ 27,930	\$ 39	\$ 18,620	\$ 47,000	50	\$ 2,350,000		\$ 28,200	\$ 25,523
Green Street Sanitary Sewer Structures	EA	4	\$ 2,940	\$ 11,760	\$ 1,960	\$ 7,840	\$ 20,000	50	\$ 1,000,000		\$ 12,000	\$ 10,861
<b>TOTAL COLLECTION SYSTEM IMPROVEMENTS PROJECT ESTIMATED COST</b>							<b>\$ 2,941,000</b>	<b>WEGHTED USEFUL LIFE</b>	<b>\$ 107,490,000</b>	<b>36.5</b>	<b>\$ 1,050,600</b>	<b>\$ 950,859</b>

## City of Grand Ledge WWTP Improvements

### Opinion of Operation, Maintenance and Replacement Costs

	Budget			
	2021-2022	Alternative 2	Alternative 3	Alternative 4
Labor	\$ 356,189	\$ 458,398	\$ 458,398	\$ 458,398
<i>Salaries/Wages</i>	\$ 219,019	\$ 321,228	\$ 321,228	\$ 321,228
<i>Overtime</i>	\$ 12,011	\$ 12,011	\$ 12,011	\$ 12,011
<i>Fringe Benefits</i>	\$ 125,159	\$ 125,159	\$ 125,159	\$ 125,159
<i>OPEB Adjustment</i>	\$ -	\$ -	\$ -	\$ -
<i>Compensated Absences Adjustment</i>	\$ -	\$ -	\$ -	\$ -
<b>Maintenance Supplies</b>	<b>\$ 42,500</b>	<b>\$ 53,669</b>	<b>\$ 62,381</b>	<b>\$ 54,569</b>
<i>Flow Retention</i>	\$ 2,125	\$ 4,250	\$ 4,250	\$ 4,250
<i>Screening</i>	\$ 7,438	\$ 7,438	\$ 7,438	\$ 18,538
<i>Grit Removal</i>	\$ 5,313	\$ 2,656	\$ 2,656	\$ 2,656
<i>Primary Clarification</i>	\$ 4,250	\$ 4,250	\$ -	\$ -
<i>Biological Treatment</i>	\$ 12,750	\$ 18,700	\$ 32,725	\$ 22,750
<i>Final Clarification</i>	\$ 2,125	\$ 2,125	\$ 2,125	\$ -
<i>Disinfection</i>	\$ 4,250	\$ 10,000	\$ 10,000	\$ 4,250
<i>Solids Handling</i>	\$ 4,250	\$ 4,250	\$ 3,188	\$ 2,125
<b>Chemicals</b>	<b>\$ 55,000</b>	<b>\$ 53,778</b>	<b>\$ 53,778</b>	<b>\$ 19,167</b>
<i>Biological Treatment</i>	\$ 18,333	\$ 26,889	\$ 26,889	\$ 10,000
<i>Disinfection</i>	\$ 18,333	\$ -	\$ -	\$ -
<i>Solids Handling</i>	\$ 18,333	\$ 26,889	\$ 26,889	\$ 9,167
<b>Contractual</b>	<b>\$ 80,000</b>	<b>\$ 80,000</b>	<b>\$ 80,000</b>	<b>\$ 80,000</b>
<b>Utilities</b>	<b>\$ 105,000</b>	<b>\$ 160,663</b>	<b>\$ 243,438</b>	<b>\$ 363,916</b>
<i>Flow Retention</i>	\$ 2,625	\$ 4,263	\$ 4,263	\$ 4,263
<i>Screening</i>	\$ 2,625	\$ 2,625	\$ 2,625	\$ 2,625
<i>Grit Removal</i>	\$ 5,250	\$ 5,250	\$ 5,250	\$ 5,250
<i>Primary Clarification</i>	\$ 2,625	\$ 3,850	\$ -	\$ 9,110
<i>Biological Treatment</i>	\$ 78,750	\$ 115,500	\$ 202,125	\$ 334,980
<i>Final Clarification</i>	\$ 2,625	\$ 2,625	\$ 2,625	\$ -
<i>Disinfection</i>	\$ 2,625	\$ 15,000	\$ 15,000	\$ 3,750
<i>Solids Handling</i>	\$ 7,875	\$ 11,550	\$ 11,550	\$ 3,938
<b>Maintenance</b>	<b>\$ 72,500</b>	<b>\$ 88,500</b>	<b>\$ 121,500</b>	<b>\$ 138,500</b>
<i>Grounds Maintenance</i>	\$ 6,000	\$ 6,000	\$ 6,000	\$ 6,000
<i>Building Maintenance</i>	\$ 25,000	\$ 25,000	\$ 25,000	\$ 25,000
<i>Vehicle Maintenance</i>	\$ 7,500	\$ 7,500	\$ 7,500	\$ 7,500
<i>Structure Maintenance</i>	\$ 4,000	\$ 6,000	\$ 6,000	\$ 4,000
<i>Equipment Maintenance</i>	\$ 30,000	\$ 44,000	\$ 77,000	\$ 96,000
<b>Equipment Rental</b>	<b>\$ -</b>	<b>\$ -</b>	<b>\$ -</b>	<b>\$ -</b>
<b>Transfer to Parks &amp; Rec</b>	<b>\$ 2,500</b>	<b>\$ 2,500</b>	<b>\$ 2,500</b>	<b>\$ 2,500</b>
<b>TOTAL</b>	<b>\$ 713,689</b>	<b>\$ 897,507</b>	<b>\$ 1,021,995</b>	<b>\$ 1,117,049</b>
<b>PRESENT WORTH OF 20 YEARS OF O&amp;M COSTS</b>	<b>\$ 13,552,000</b>	<b>\$ 17,042,000</b>	<b>\$ 19,406,000</b>	<b>\$ 21,210,000</b>

# Appendix 7

---



MICHIGAN DEPARTMENT OF ENVIRONMENT, GREAT LAKES, AND ENERGY  
**DISADVANTAGED COMMUNITY STATUS DETERMINATION WORKSHEET**

The following data is required from each municipality to assess the disadvantaged community status. Please provide the necessary information and return to:

Mark Conradi  
Water Infrastructure Financing Section  
Finance Division  
[conradim@michigan.gov](mailto:conradim@michigan.gov)

Please contact Mark Conradi ([conradim@michigan.gov](mailto:conradim@michigan.gov)) with any questions on the completion of the form.

Please check the box this determination is for:

DWSRF

CWSRF

Total amount of anticipated debt for the proposed project, if applicable.

38,000,000

Annual payments on the existing debt for the system.

587,962

Total operation, maintenance, and replacement expenses for the system on an annual basis.

1,768,174

Number of residential equivalent users (REUs) in the system.

4,035

**For determinations made using anticipated debt, a final determination will be made based upon the awarded loan amount.**

If you need this information in an alternate format, contact [EGLE-Accessibility@Michigan.gov](mailto:EGLE-Accessibility@Michigan.gov) or call 800-662-9278.

EGLE does not discriminate on the basis of race, sex, religion, age, national origin, color, marital status, disability, political beliefs, height, weight, genetic information, or sexual orientation in the administration of any of its programs or activities, and prohibits intimidation and retaliation, as required by applicable laws and regulations. Questions or concerns should be directed to the Nondiscrimination Compliance Coordinator at [EGLE-NondiscriminationCC@Michigan.gov](mailto:EGLE-NondiscriminationCC@Michigan.gov) or 517-249-0906.

This form and its contents are subject to the Freedom of Information Act and may be released to the public.

# Appendix 8

---

AFFIDAVIT OF PUBLICATION  
LSJ MEDIA  
300 S. Washington Square, Suite 300, Lansing, MI 48933

State of Michigan, County of Macomb } ss

IN THE MATTER OF:

CITY OF GRAND LEDGE  
Attn.: GREG  
310 GREENWOOD ST.  
GRAND LEDGE, MI 48837

Being duly sworn, says that he/she is authorized by the publisher of Grand Ledge Independent, to swear that a certain notice, a copy of which is annexed here to, was published in the following publication:

1. Published in the English language for the dissemination of general and/or legal news, and
2. Has a bonfide list of paying customers or has been published at least once a week in the same community without interruption for at least 2 years, and
3. Has been established, published and circulated at least once a week without interruption for at least one (1) year in the community where the publication is to occur.

Grand Ledge Independent, 03/20/22

  
Tyna Smith

SUBSCRIBED AND SWORN TO BEFORE ME THIS 23rd  
DAY OF March, 2022

  
GINA ANNE HUFF  
Notary Public State of Michigan  
County of Livingston  
My commission expires March 9, 2023

Acting in the County of Macomb

0005175586, LSJ-L13877

LSJ-LSJ-Grand Ledge Independent

CITY OF GRAND LEDGE  
NOTICE OF PUBLIC HEARING  
WASTEWATER TREATMENT PLANT AND COLLECTION  
SYSTEM IMPROVEMENTS

The Grand Ledge City Council will hold a public hearing during its regular meeting at 7:30 p.m. on 09 May 2022, in the Council Chambers, City Hall, 310 Greenwood St., Grand Ledge MI 48837, to consider and receive public input on a proposed Wastewater Treatment Plant and Collection System Improvements project. The plan detailing the proposed project will be available on the City's website at [www.cityofgrandledge.com](http://www.cityofgrandledge.com) on and after 01 April 2022 and at City Hall, 310 Greenwood St., Grand Ledge MI 48837.

The purpose of the proposed project is to make improvements to the existing sanitary sewer collection system and treatment system. The improvements will allow for the continued treatment of sanitary sewage throughout the service area in accordance with the current National Pollutant Discharge Elimination System permit.

Project elements include collection system improvements, an influent equalization tank, a fine screening system, a vortex grit removal system, a membrane bioreactor secondary treatment system, an ultraviolet disinfection system, solids handling improvements, site works, and ancillary improvements as required to provide a complete and functioning system.

Long-term positive impacts from the project include improved reliability of the treatment system and improved treatment efficiencies. Short-term impacts related to construction activities could include increased construction traffic and disturbances in the immediate vicinity of the Wastewater Treatment Plant site. Wastewater Treatment Plant improvements are estimated to require less than one acre of additional area.

The current total estimated project cost is \$35,000,000. The project cost will be funded through a low-interest Michigan Department of Environment, Great Lakes, and Energy State Revolving Fund loan.

The City Council invites anyone interested to attend and offer comments at the public hearing. Written comments can be mailed to or placed in the drop box in front of City Hall, 310 Greenwood St., Grand Ledge MI 48837, or emailed to [cityhall@cityofgrandledge.com](mailto:cityhall@cityofgrandledge.com). All written comments received before the hearing record is closed on 09 May 2022 will receive responses in the final project plan.

Please call (517) 627-2149 or email [cityhall@cityofgrandledge.com](mailto:cityhall@cityofgrandledge.com) for further information or to request accommodations for disabilities.

Gregory Newman, City Clerk  
GLI-5175586

03/20/2022